

CONTRACT HYGIENIC BAG DISPENSER / DISPENSADOR BOLSAS HIGIENICAS

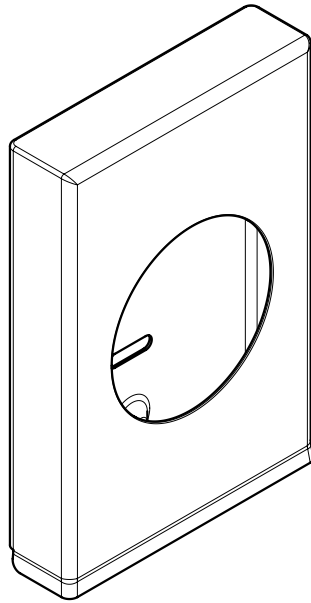

FIJACIÓN PARED WALL FIXATION

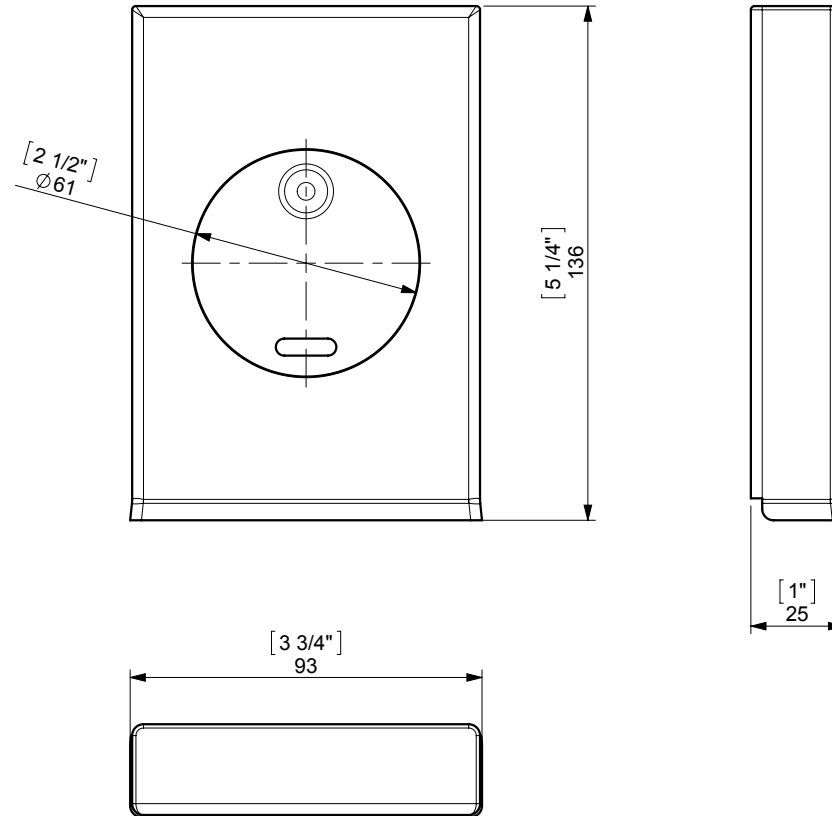
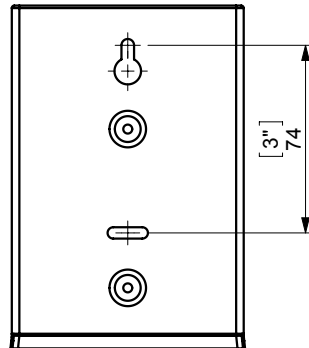

espec_605

Peso / Weight / Poids : 0,25 kg.

Data / Datos / Données:

Normas / Regulations / Normes: UNE 67100, **UNE EN 3497**, **UNE EN ISO 1456**, **UNE EN ISO 9227**, **UNE EN ISO 4541**, **UNE EN ISO 2819**, UNE-EN ISO 4541

Imágenes no a escala / Draw not to scale / Echelle non respectée

Sonia S.A se reserva el derecho de realizar cualquier cambio sin previo aviso
Sonia S.A has the right to make changes without notice
Sonia S.A se réserve le droit de procéder à tout changement sans notification préalable



www.sonia-sa.com