

Kräus[®]

INSTALLATION GUIDE

Single Lever Pull-Down Kitchen Faucet

KPF-1630

Congratulations on the purchase of your new Kraus plumbing fixture!

Please keep the box and packaging materials until your product is completely installed. If you have any questions, require technical assistance, or have any problems with your product:



DO NOT RETURN TO STORE

Please contact our Customer Service Team

1-800-775-0703 / customerservice@kraususa.com

Have the model number available, and retain a copy of your receipt with purchase date for reference.

If for any reason this product does not meet your expectations, please be sure to repack this product in the original box and packaging material to avoid damage during transit.

Prior to Installation:

- Make sure you have all necessary parts by checking the diagram and parts list. If any part is missing or damaged, please contact Kraus Customer Service at 800-775-0703 for a replacement
- Turn off the cold and hot water at the angle stops and turn on the old faucet to release any built up pressure
- Flush angle stops to release any debris prior to installation
- Pre-drilled hole size requirement: 1-3/8" (min) – 1-1/2" (max)
- Max countertop thickness: 1-3/8
- 1, 2, or 3 hole installation

Tools Required

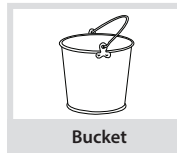
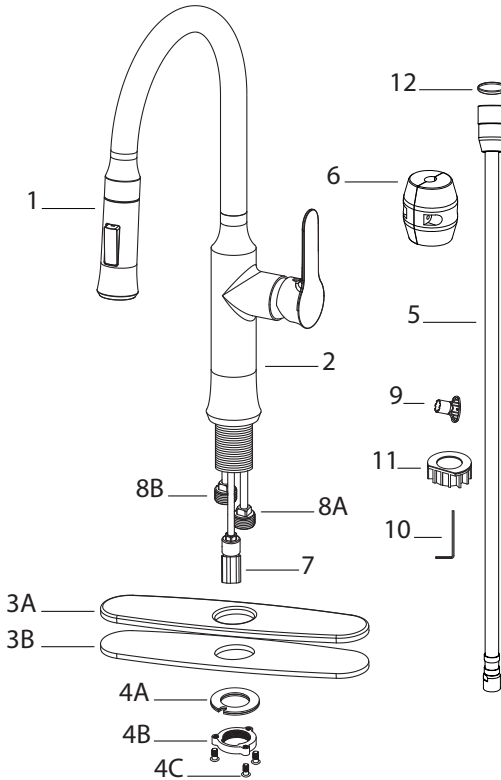
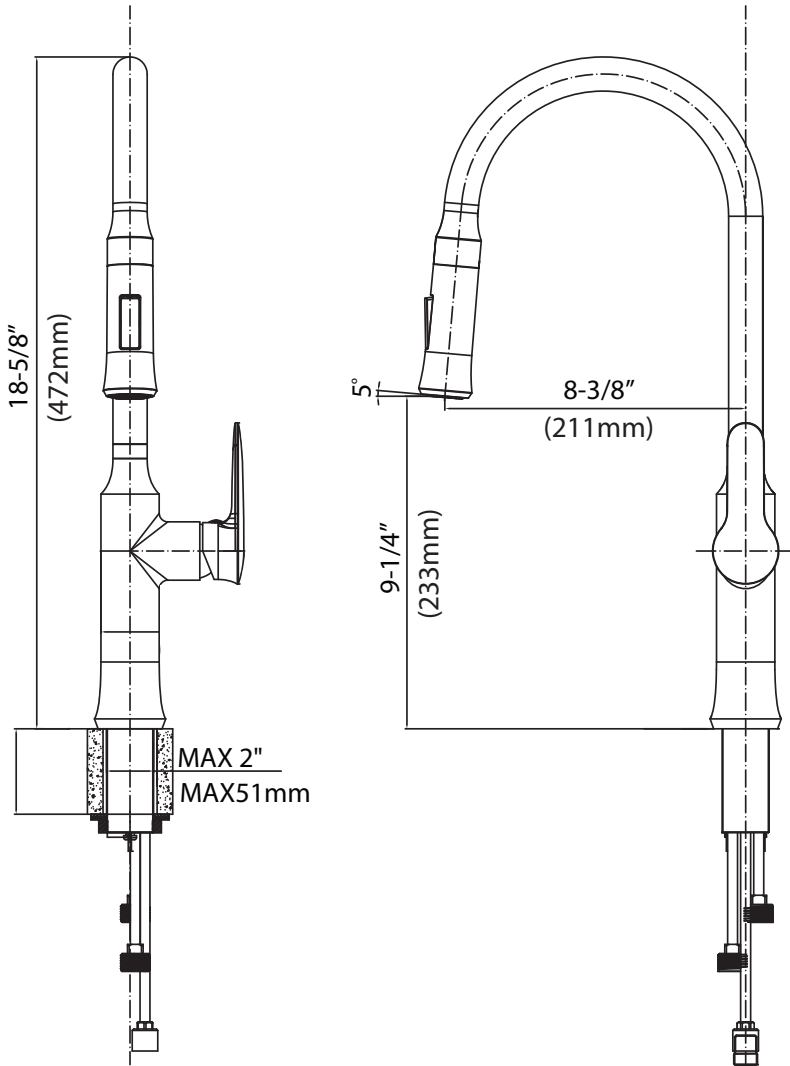

Diagram and Parts List



1. Spray Head
2. Faucet Body
3. Deck Plate Assembly
 - A. Deck Plate
 - B. Base Plate
4. Mounting Hardware
 - A. Rubber & Metal Washer
 - B. Mounting Nut
 - C. Mounting Screws
5. Spray Hose
6. Weight
7. Check Valve
8. Hot and Cold Copper Lines
 - A. Cold
 - B. Hot
9. Aerator Key
10. Hex Wrench
11. Faucet Extender
12. Washer

Faucet Installation Procedure



Installer Tip:

Shut off main water supply before installing new faucet

Step 1: Remove mounting hardware

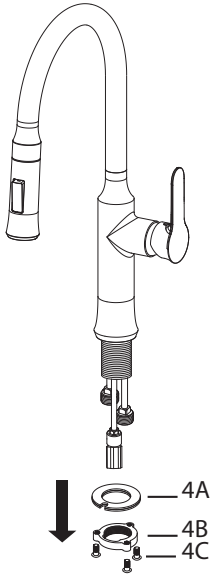

Remove the mounting screws (4C), mounting nut (4B), and rubber & metal washer (4A) from the mounting pipe

Step 2A: Faucet installation - with deck plate

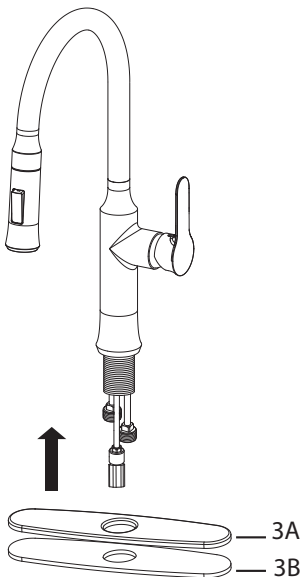

For three-hole installation: Deck plate (3A), base plate (3B), and silicone sealant (optional) are required

Step 2B: Faucet installation - without deck plate

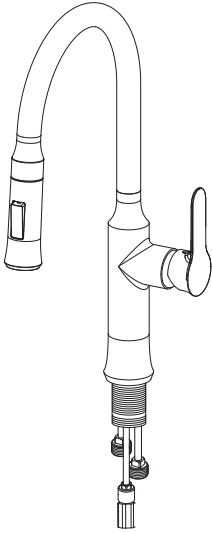

For single-hole installation:
Deck plate (3A), base plate
(3B), and silicone sealant
are **NOT** required

Step 3: Install faucet and mounting hardware

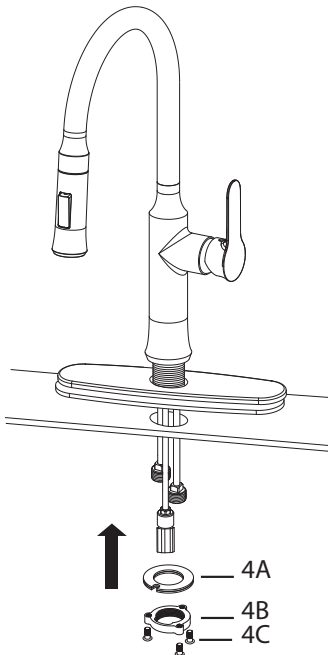

Insert faucet body (2) into
hole in countertop or deck
plate assembly (3). Install
mounting hardware (4A, B
&C) from underneath the
countertop

Step 4: Secure mounting hardware

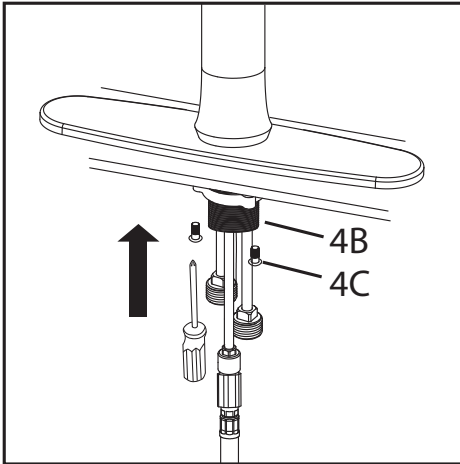

Adjust direction of faucet body (2) so that handle is on right side of faucet. Tighten mounting nut (4B) until snug. Tighten mounting screws (4C) to nut with a Phillips screwdriver until snug

Step 5: Attach spray hose and counterweight

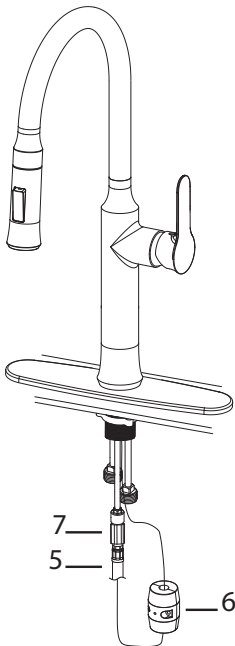

Connect spray hose (5) to check valve (7) attached to supply line. Install weight (6) on lowest vertical point on spray hose (5)

Step 6: Connect waterlines

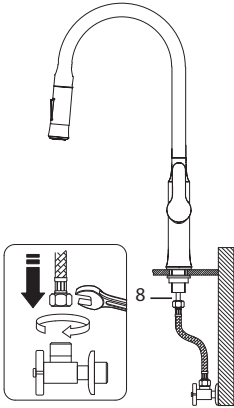

Connect waterlines (not included) to hot and cold copper lines (8). Connect waterlines (not included) to angle stops. Tighten both ends of waterlines with a wrench until snug. Turn on hot and cold angle stops and check for leaks

Step 7: Flush spray hose

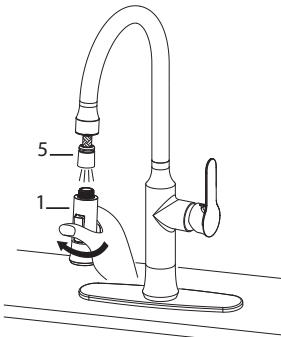

Remove spray head (1) from spray hose (5). Hold tip of spray hose (5). Turn faucet on and let the water run for 60 seconds to flush any debris

NOTE: Please make sure washer (12) is installed attaching spray head to hose

Step 8 Check for leaks

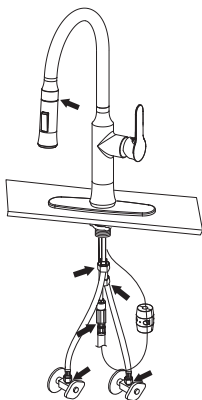

Check for leaks at the connections. Retighten if necessary

Replacement Parts

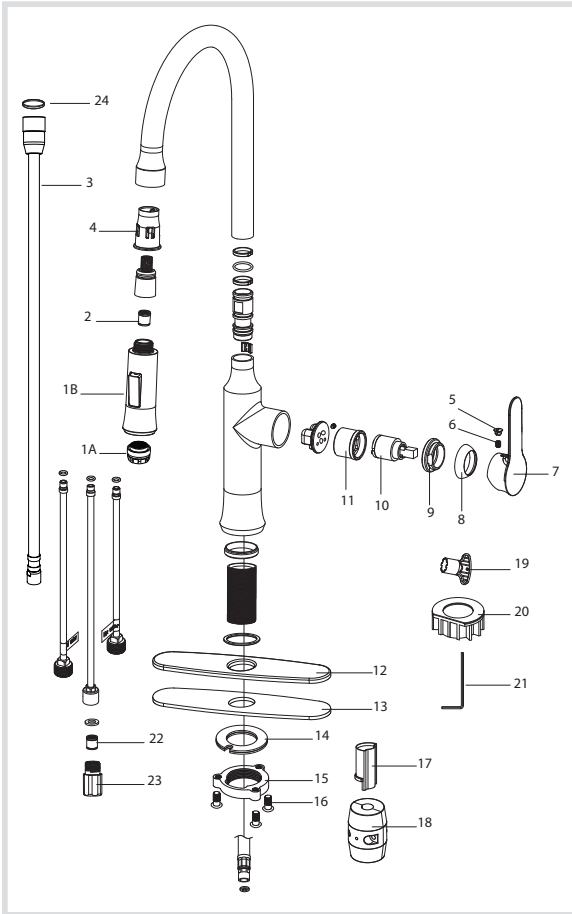

1. a. Aerator
b. Spray Head
2. Check Valve
3. Spray Hose
4. Hose Guide
5. Handle Button
6. Set Screw
7. Metal Handle
8. Cartridge Cover
9. Locking Nut
10. Cartridge
11. Cartridge Housing
12. Deck Plate
13. Base Plate
14. Rubber & Metal Washer
15. Mounting Nut
16. Mounting Screws
17. Protective Sleeve
18. Weight
19. Aerator Key
20. Faucet Extender
21. Hex Wrench
22. Check Valve
23. Connector
24. Washer

Care & Maintenance

*To keep the product clean & shining, follow the steps below:

1. Rinse with clean water & dry with a soft cloth
2. Do not clean with soaps, acid, polish, abrasives, or harsh cleaners
3. Do not use cloth with a coarse surface
4. Unscrew the aerator and clean when necessary

*This installation manual is subject to change without further notice.

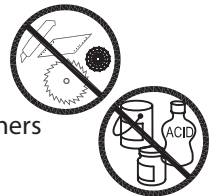

Trouble - Shooting

If you have followed the instructions carefully and your faucet still does not work properly, take the following corrective steps:

PROBLEM	CAUSE	ACTION
Leakage under faucet handle	Locking nut has come loose or cartridge needs to be reseated	Remove button located at top of handle. Loosen set screw with hex wrench. Remove handle and unscrew cartridge cover by hand. Tighten locking nut with an adjustable wrench
Water does not shut off completely	Cartridge may need to be adjusted or replaced	Remove button located at top of handle. Loosen set screw with hex wrench. Remove handle and unscrew cartridge cover by hand. Unscrew locking nut with an adjustable wrench. Remove ceramic disc cartridge. Check for cracks, and if O-ring is seated correctly. Reseat cartridge
Leaking between spray head and the hose	Spray head may be loose or washer is not seated correctly in the hose connection	Tighten spray head by hand until snug. Make sure washer is seated correctly
Hose does not retract	Weight may be installed incorrectly	Readjust weight on hose
Low flow	Aerator may be clogged	Unscrew aerator with aerator key. Hold tip of spray head and turn on water to flush debris

Maintenance - Cartridge Replacement

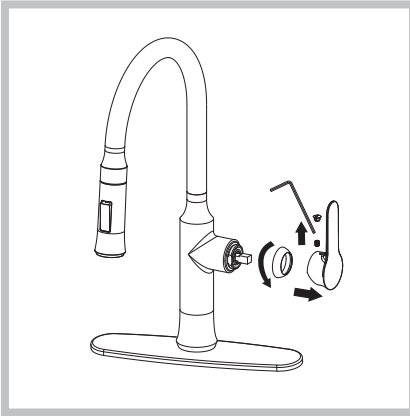

Step 1: Remove button located at the top of the handle. Loosen the set screw with a hex wrench. Remove the handle and unscrew cartridge cover by hand

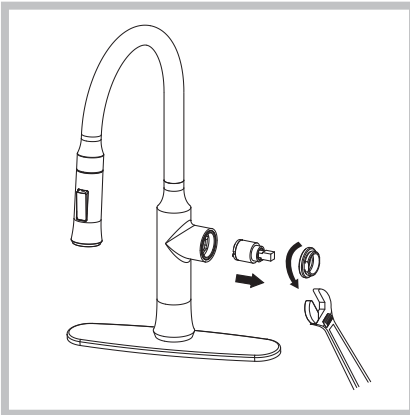

Step 2: Unscrew the locking nut with an adjustable wrench. Remove ceramic disc cartridge

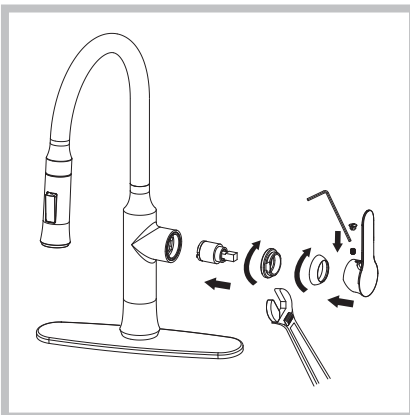

Step 3: Place the new cartridge in the handle seat. Secure the cartridge with the locking nut and assemble the handle

Codes/Standards Applicable:



NSF/ANSI Standard 61 certified by IAPMO
NSF/ANSI Standard 372 certified by IAPMO



Meets ASME A112.18.1M/A112.18.1
1.75gpm 6.6L/min maximum

FAUCET WARRANTY

Kraus products are manufactured and tested to the highest quality standards by Kraus USA Inc. ("Kraus"). Kraus extends this warranty to the original purchaser for personal household use of the "Faucet" in its original location. The warranty is non-transferable.

Kraus warrants the structure and finish of the product to be free from defects in material and workmanship under normal usage for the lifetime of the product. The warranty commences from the initial date of purchase by the owner or trade professional, from an authorized Kraus dealer, through the lifetime of the original owner or end-user.

Kraus warrants the mechanical component (**sprayhead assembly**) of the product to be free from defects in material and workmanship under normal usage for a period of one (1) year. The warranty commences from the initial date of purchase by the owner or trade professional, from an authorized Kraus dealer, through the one (1) year term of the original owner or end-user.

Kraus warrants the mechanical component (**cartridge**) of the product to be free from defects in material and workmanship under normal usage for a period of five (5) years. The warranty commences from the initial date of purchase by the owner or trade professional, from an authorized Kraus dealer, through the five (5) year term of the original owner or end-user.

Any product reported to the authorized dealer or to Kraus as being defective within the warranty period will be repaired or replaced with a product of equal value at the option of Kraus. This warranty extends to the original owner or end-user, and is not transferable to a subsequent owner.

RESTRICTIONS

This warranty does not cover antediluvian, discontinued, or display products, whether such items are purchased at discount outlets, unauthorized dealers, and/or sold on clearance. This warranty does not cover instances of negligence, misuse, abuse, improper installation, carelessness, accident, hard water or mineral deposits, exposure to corrosive materials, misapplication, damages caused by improper maintenance, alteration of the product, or failure to follow care or installation instructions enclosed with your product. Avoid using abrasive cleaners such as powders, bleach, ammonia, alcohol, or chlorine. Avoid using abrasive pads, steel wool, or wire brushes, as these will damage and wear down the finish.

This warranty does not apply to Products that have not been installed or operated in accordance with instructions supplied by Kraus and all applicable rules, regulations, and legislation pertaining to such installations.

This warranty does not apply unless the Kraus product is installed by a fully insured and licensed trade professional. Kraus insists that such professionals have experience in the installation of bathroom and kitchen manufactured goods. This warranty does not cover labor charges or costs of removal and reinstallation of said product. This warranty does not allow recovery of incidental or consequential damages, such as loss of use, delay, property damage, or other consequential damages, and Kraus accepts no liability for such damages.

This warranty does not cover Marine or Outdoor Installation.

Except as otherwise provided above, Kraus makes no warranties, expressed or implied, including warranties of merchantability and fitness for a particular purpose, or compliance with any code. Shipping charges will be covered for

the first (1) year of the warranted replacement part or product (HI, AK, and Puerto Rico shipping charges may apply). International shipping fees are not included.

COMMERCIAL WARRANTY

Kraus extends the above warranty for a period of one (1) year to purchasers of products for industrial, commercial, and business use.

All incidental or consequential damages are specifically excluded. No additional warranties, express or implied, are given, including but not limited to any implied warranty of merchantability or fitness for a particular purpose.

Some states do not allow the exclusion or limitation of incidental or consequential damages or limitations on how long an implied warranty lasts, so the above limitations or exclusions may not apply to you.

This warranty gives you specific legal rights, and you may also have other rights which vary from state to state.

If you are a homeowner please contact a Kraus Customer Service Representative at:

Kraus USA, Inc.
12 Harbor Park Drive
Port Washington, NY 11050
Toll-free 800-775-0703
Customerservice@kraususa.com

If you are a plumbing contractor or trade professional please contact a Kraus Pro Representative at:

Kraus USA, Inc.
12 Harbor Park Drive
Port Washington, NY 11050
516-801-8955
Proservice@kraususa.com

If you are an Authorized Partner please contact a Partner Support Representative at:

Kraus USA, Inc.
12 Harbor Park Drive
Port Washington, NY 11050
516-801-8954
Partnersupport@kraususa.com

In requesting warranty service, please be ready to provide:

1. Proof of purchase.
2. A description of the problem.

Download the Kraus Care & Maintenance Guide at:

<http://www.kraususa.com/maintenance>

IMPORTANT

Register Your Kraus Product

Activate Your Warranty

Access Premium Customer Support

Get Product Information

REGISTER TODAY

<http://www.kraususa.com/registration>



Kräus[®]
www.kraususa.com