



Nola™ Single Lever Flex Commercial Style Kitchen Faucet

KPF-1640

Congratulations on the purchase of your new Kraus plumbing fixture!

Please keep the box and packaging materials until your product is completely installed. If you have any questions, require technical assistance, or have any problems with your product:



DO NOT RETURN TO STORE

Please contact our Customer Service Team

1-800-775-0703 / customerservice@kraususa.com

Have the model number available, and retain a copy of your receipt with purchase date for reference.

If for any reason this product does not meet your expectations, please be sure to repack this product in the original box and packaging material to avoid damage during transit.

Prior to Installation:

- Make sure you have all necessary parts by checking the diagram and parts list. If any part is missing or damaged, please contact Kraus Customer Service at 800-775-0703 for a replacement
- Turn off the hot and cold water supply at the angle stops and turn on the old faucet to release any built up pressure. Remove existing faucet. Clean sink or countertop to remove any debris, plumber's putty, or silicone
- Place bucket under angle stops. Turn on to flush any debris prior to installing new plumbing. Shut off angle stops
- Pre-drilled hole size requirement: 1-3/8"
- Max countertop thickness without deck plate: 1-3/8"
- 1, 2, or 3 hole installation

For technical assistance or replacement parts, please contact Kraus Customer Service and one of our representatives will be happy to help:
Toll-Free: 800-775-0703 or Customerservice@kraususa.com

Tools you will need



Adjustable Wrench



Bucket

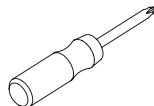

Phillips Screwdriver



Safety Goggles

Diagram and Parts List

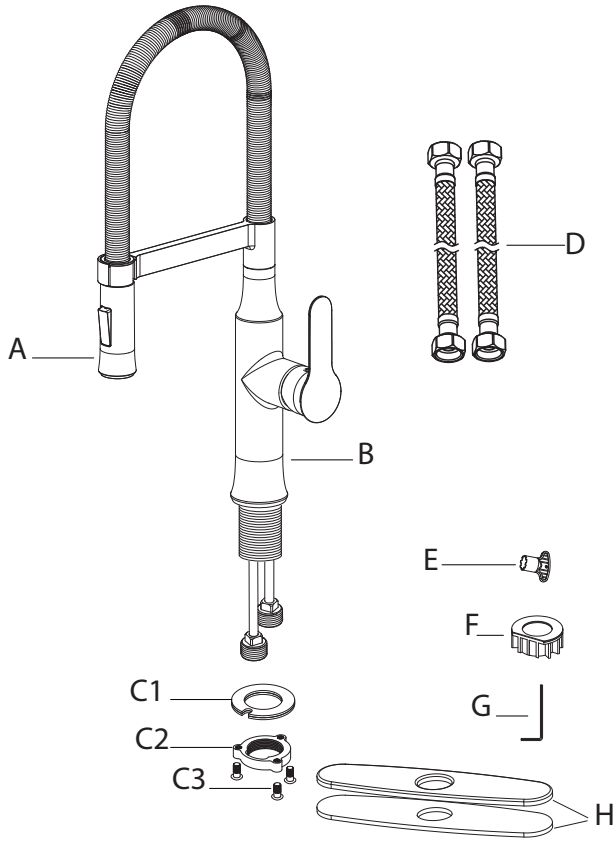

A. Spray Head

B. Faucet Body

C. Mounting Hardware

C1. Rubber & Metal Washer

C2. Mounting Nut

C3. Mounting Screw

D. Hot & Cold Waterlines

E. Aerator Key

F. Faucet Extender (used for top mount sinks only)

G. 2.5 mm Hex Wrench

H. Deck Plate Assembly

Faucet Dimensions

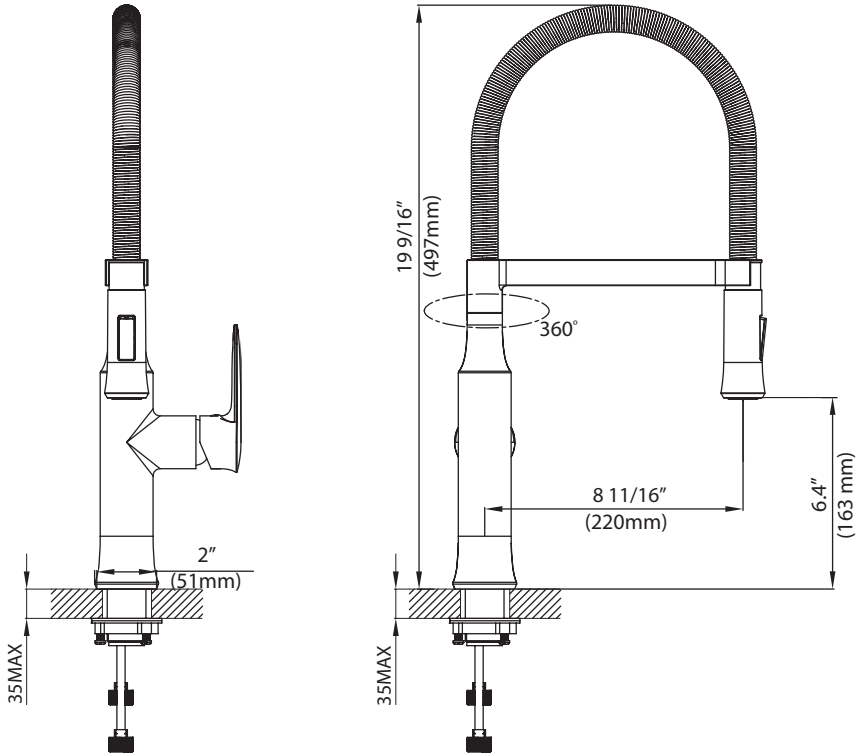

Step 1: Remove mounting hardware

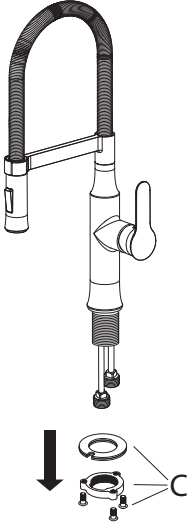

Remove mounting hardware (C) from mounting pipe

Step 2: Install faucet and mounting hardware

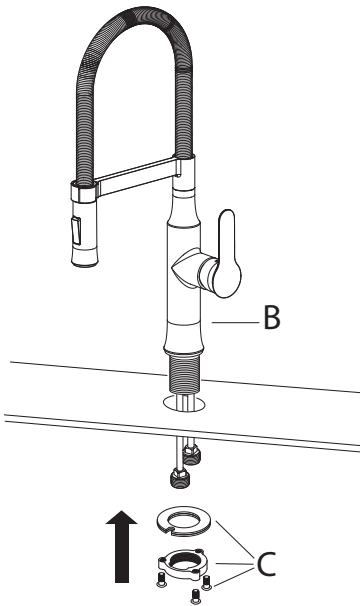

Insert faucet body (B) into hole in countertop or sink. Install mounting hardware (C) from underneath countertop

Note : Deck plate assembly (H) can be used to cover preexisting holes

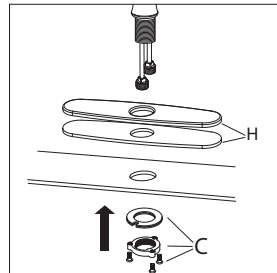

Step 3: Secure mounting hardware

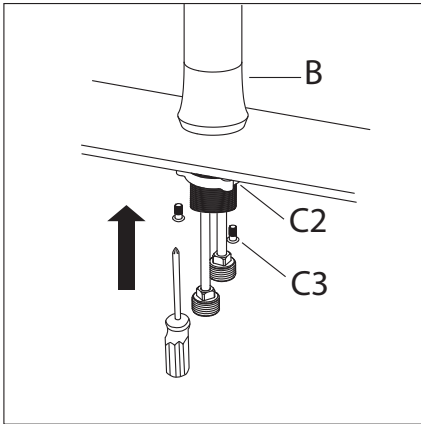

Adjust the direction of faucet body (B). Tighten mounting nut (C2) until snug. Tighten mounting screws (C3) to nut with a Phillips screwdriver until snug

Step 4: Connect waterlines

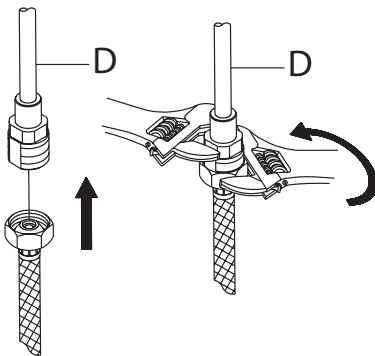

Connect waterlines (D) to copper lines and angle stops. Tighten both ends of waterlines with an adjustable wrench until snug. Turn on angle stops and check for leaks (DO NOT TURN FAUCET ON)

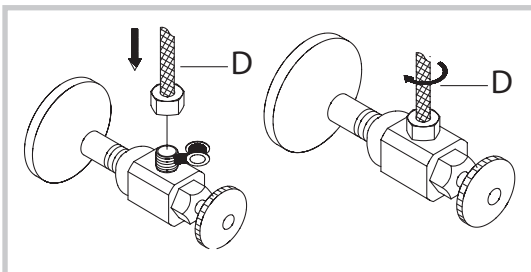

Step 5: Flush spray hose

Remove spray head (A) from hose. Hold tip of hose. Turn faucet on for 60 seconds to flush any debris

Installer Tip: Please make sure washer is installed prior to attaching spray head to hose

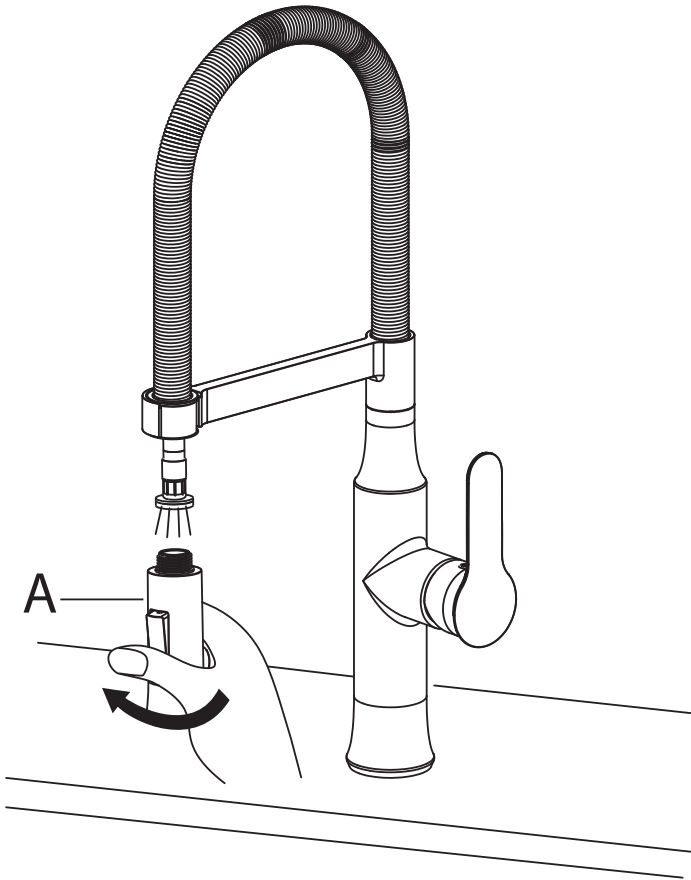

Step 6: Check for leaks

Check for leaks at the connections

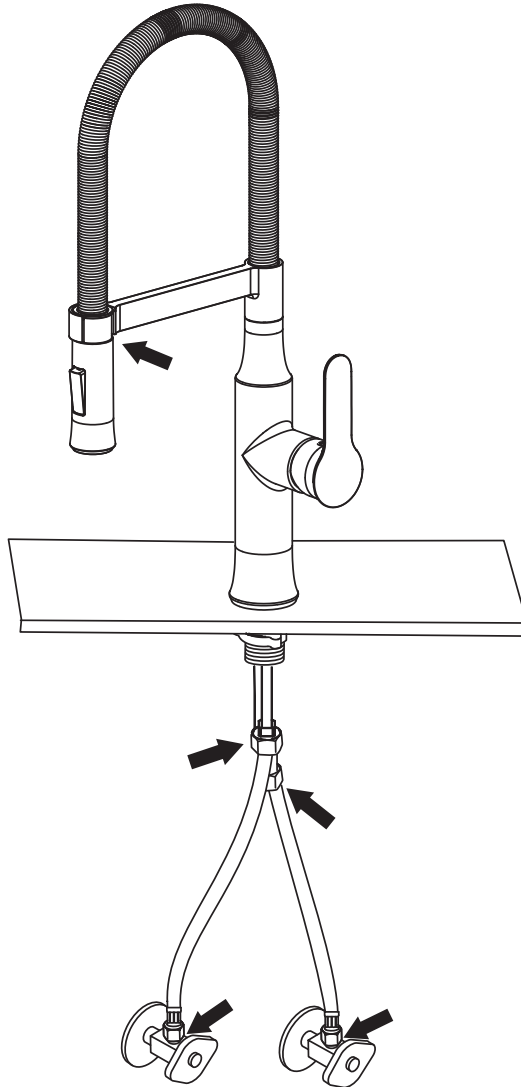

Replacement Parts

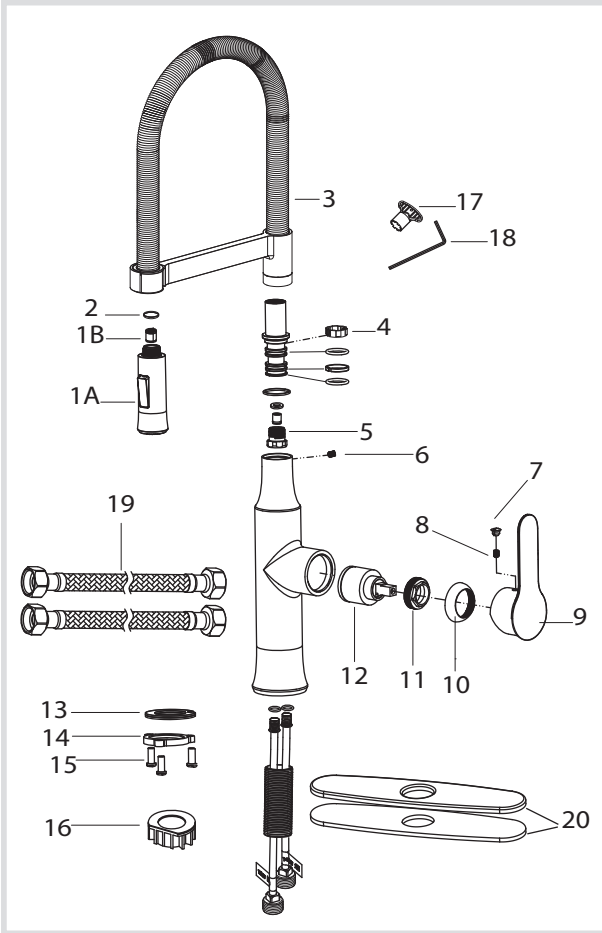

1. A. Spray Head
- B. Check Valve
2. Washer
3. Spray Hose & Spring
4. Pivot Ring
5. Check Valve Connector
6. Set Screw
7. Cover Button
8. Set Screw
9. Metal Handle
10. Cartridge Cover
11. Locking Nut
12. Cartridge
13. Rubber & Metal Washer
14. Mounting Nut
15. Mounting Screws
16. Faucet Extender
17. Aerator Key
18. 2.5 mm Hex Wrench
19. Hot & Cold Waterlines
20. Deck Plate Assembly

Care & Maintenance

*To keep the product clean & shining, follow the steps below:

1. Rinse with clean water & dry with a soft cloth
2. Do not clean with soaps, acid, polish, abrasives, or harsh cleaners
3. Do not use cloth with a coarse surface
4. Unscrew the aerator and clean when necessary

*This installation manual is subject to change without further notice.

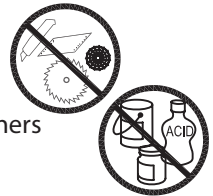

Trouble - Shooting

If you have followed the instructions carefully and your faucet still does not work properly, take the following corrective steps:

| PROBLEM | CAUSE | ACTION |
|-------------------------------------|---|---|
| Leaking from faucet handle | Locking nut (11) may have come loose or cartridge (12) may need to be reseated | Remove cover button (7). Loosen set screw (8) with 2.5 mm hex wrench (18). Remove handle (9). Unscrew cartridge cover (10) by hand. Tighten locking nut (11) with an adjustable wrench |
| Water does not shut off completely | Cartridge (12) may need to be adjusted or replaced | Remove cover button (7). Loosen set screw (8) with 2.5 mm hex wrench (18). Remove handle (9). Unscrew cartridge cover (10) by hand. Unscrew locking nut (11) with an adjustable wrench. Remove cartridge (12). Check for cracks, and if O-ring is seated correctly. Reseat cartridge (12) |
| Leaking between spray head and hose | Spray head (1A) may be loose or washer (2) may not be seated correctly in the hose connection | Tighten spray head (1A) by hand until snug. Make sure washer (2) is seated correctly |
| Low flow | Check valve connector (5) may be clogged with debris | Loosen set screw (6). Remove spray hose & spring (3). Unscrew check valve connector (5) located at the bottom of spray hose & spring (3). Soak in 50/50 solution of warm water and vinegar for 5 minutes. Reinstall check valve connector (5) and spray hose & spring (3) |

Maintenance - Cartridge Replacement

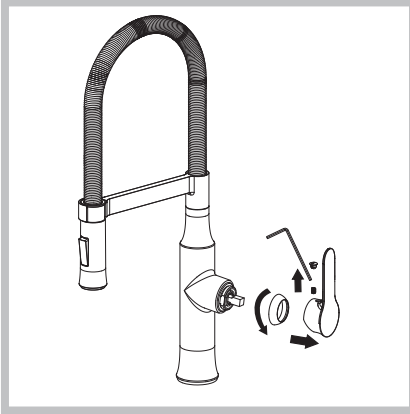

Step 1: Remove button located at the top of the handle. Loosen the set screw with a hex wrench. Remove the handle and unscrew cartridge cover by hand



Step 2: Unscrew the locking nut with an adjustable wrench. Remove ceramic disc cartridge

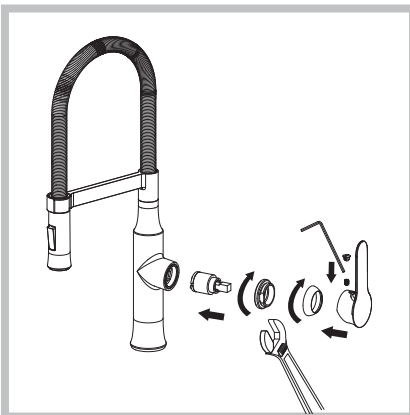

Step 3: Place the new cartridge in the handle seat. Secure the cartridge with the locking nut and assemble the handle

Codes / Standards Applicable:



NSF/ANSI Standard 61 certified by IAPMO
NSF/ANSI Standard 372 certified by IAPMO



Meets ASME A112.18.1M/A112.18.1
1.75gpm 6.6L/min maximum

FAUCET WARRANTY

Kraus products are manufactured and tested to the highest quality standards by Kraus USA Inc. ("Kraus"). Kraus extends this warranty to the original purchaser for personal household use of the "Faucet" in its original location. The warranty is non-transferable.

Kraus warrants the structure and finish of the product to be free from defects in material and workmanship under normal usage for the lifetime of the product. The warranty commences from the initial date of purchase by the owner or trade professional, from an authorized Kraus dealer, through the lifetime of the original owner or end-user.

Kraus warrants the mechanical component (**sprayhead assembly**) of the product to be free from defects in material and workmanship under normal usage for a period of one (1) year. The warranty commences from the initial date of purchase by the owner or trade professional, from an authorized Kraus dealer, through the one (1) year term of the original owner or end-user.

Kraus warrants the mechanical component (**cartridge**) of the product to be free from defects in material and workmanship under normal usage for a period of five (5) years. The warranty commences from the initial date of purchase by the owner or trade professional, from an authorized Kraus dealer, through the five (5) year term of the original owner or end-user.

Any product reported to the authorized dealer or to Kraus as being defective within the warranty period will be repaired or replaced with a product of equal value at the option of Kraus. This warranty extends to the original owner or end-user, and is not transferable to a subsequent owner.

RESTRICTIONS

This warranty does not cover antediluvian, discontinued, or display products, whether such items are purchased at discount outlets, unauthorized dealers, and/or sold on clearance.

This warranty does not cover instances of negligence, misuse, abuse, improper installation, carelessness, accident, hard water or mineral deposits, exposure to corrosive materials, misapplication, damages caused by improper maintenance, alteration of the product, or failure to follow care or installation instructions enclosed with your product. Avoid using abrasive cleaners such as powders, bleach, ammonia, alcohol, or chlorine. Avoid using abrasive pads, steel wool, or wire brushes, as these will damage and wear down the finish.

This warranty does not apply to Products that have not been installed or operated in accordance with instructions supplied by Kraus and all applicable rules, regulations, and legislation pertaining to such installations.

This warranty does not apply unless the Kraus product is installed by a fully insured and licensed trade professional. Kraus insists that such professionals have experience in the installation of bathroom and kitchen manufactured goods.

This warranty does not cover labor charges or costs of removal and reinstallation of said product. This warranty does not allow recovery of incidental or consequential damages, such as loss of use, delay, property damage, or other consequential damages, and Kraus accepts no liability for such damages.

This warranty does not cover Marine or Outdoor Installation.

Except as otherwise provided above, Kraus makes no warranties, expressed or implied, including warranties of

merchantability and fitness for a particular purpose, or compliance with any code.

Shipping charges will be covered for the first (1) year of the warranted replacement part or product (HI, AK, and Puerto Rico shipping charges may apply). International shipping fees are not included.

COMMERCIAL WARRANTY

Kraus extends the above warranty for a period of one (1) year to purchasers of products for industrial, commercial, and business use.

All incidental or consequential damages are specifically excluded. No additional warranties, express or implied, are given, including but not limited to any implied warranty of merchantability or fitness for a particular purpose.

Some states do not allow the exclusion or limitation of incidental or consequential damages or limitations on how long an implied warranty lasts, so the above limitations or exclusions may not apply to you.

This warranty gives you specific legal rights, and you may also have other rights which vary from state to state.

If you are a homeowner please contact a Kraus Customer Service Representative at:

Kraus USA, Inc.
12 Harbor Park Drive
Port Washington, NY 11050
Toll-free 800-775-0703
Customerservice@kraususa.com

If you are a plumbing contractor or trade professional please contact a Kraus Pro Representative at:

Kraus USA, Inc.
12 Harbor Park Drive
Port Washington, NY 11050
516-801-8955
Proservice@kraususa.com

If you are an Authorized Partner please contact a Partner Support Representative at:

Kraus USA, Inc.
12 Harbor Park Drive
Port Washington, NY 11050
516-801-8954
Partnersupport@kraususa.com

In requesting warranty service, please be ready to provide:

1. Proof of purchase.
2. A description of the problem.

Download the Kraus Care & Maintenance Guide at:

<http://www.kraususa.com/maintenance>

IMPORTANT

Register Your Kraus Product

Activate Your Warranty

Access Premium Customer Support

Get Product Information

REGISTER TODAY

<http://www.kraususa.com/registration>



Kräus[®]
www.kraususa.com