

SANTEC

FLUID IMAGINATION

DESIGNER SERIES

1/2" Thermostatic trim with
Volume control /
2-Way diverter /
3-Way diverter



KEEP THIS INSTRUCTION BOOKLET FOR FUTURE REFERENCE

Important : Please register your product online at www.santecfaucet.com within 30 days of purchase. Santec reserves the right to request additional documents before servicing warranty requests.

SANTEC has the right to make necessary design changes where applicable.

*Illustration may not depict actual products

1/2" THERMOSTATIC VALVE AND TRIM

Keep this instruction booklet for future reference

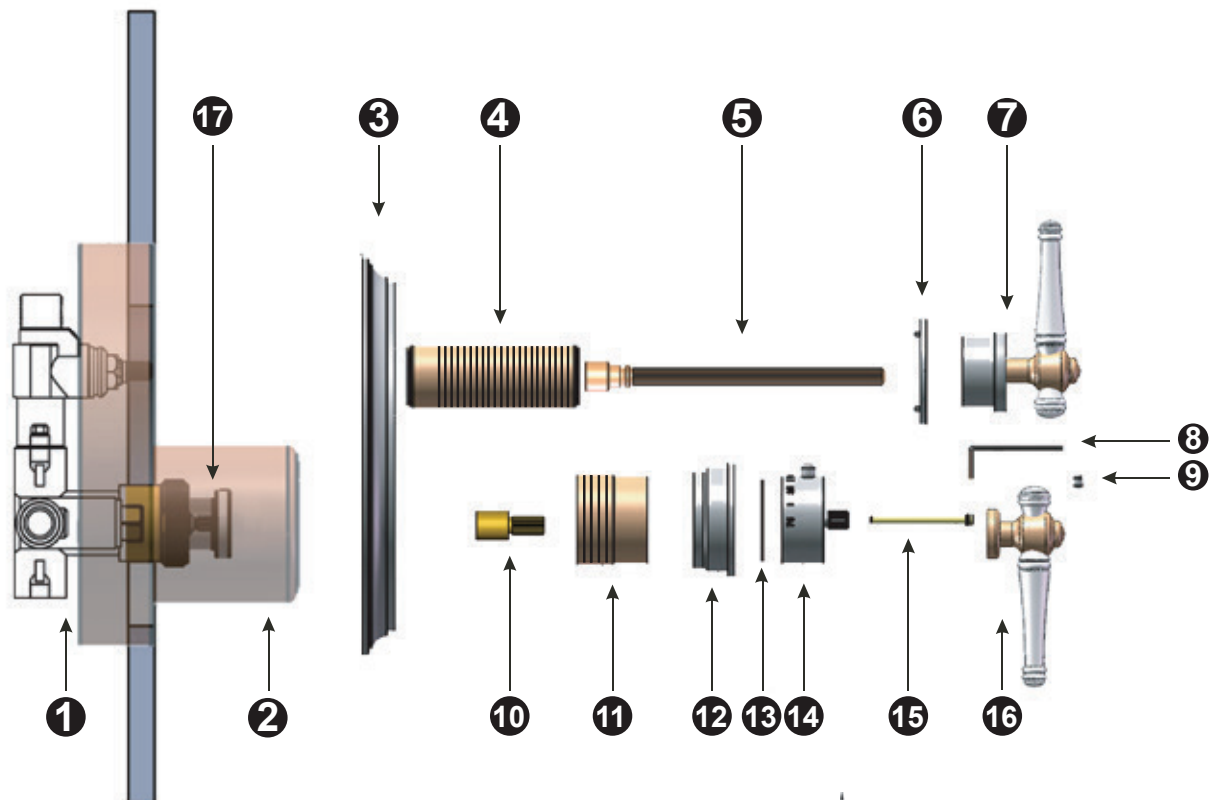

* Please specify the finish when ordering the part.

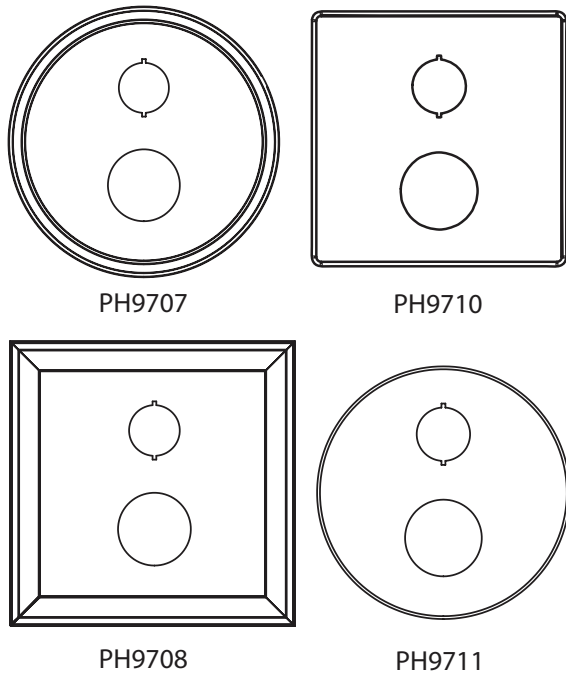

	Part Description	Part #
1	Complete Thermostatic Valve	TH-8000/8200/8300
2	Mud Guard	TH-7000-1
3	Plate	PH9711, PH9707, PH9708, PH9710
4	All Thread Extension	PM-1179
5	Diverter Broach Extension	PM-007-1
6	Diverter Ring	PH9700/9700-1/9701
7	On/Off Handle Assembly	-VARIES-
8	Allen Key	PM-033
9	Set Screw	PM-027
10	Broach Extension	SA255
11	Thermostatic Threaded Sleeve	P00019
12	Thermostatic Flange	P00018
13	Teflon Washer	PM-831
14	Thermostatic Dial	PH9712
15	Long Stem Screw	PM-5-4X
16	Thermostatic Handle	-VARIES-
17	Temperature Restrictor	TH-7000-3

1/2" THERMOSTATIC EXTENSION KIT

If the valve is roughed too far into the wall, please use the extension kit provided in the clear plastic bag. To install this kit, first thread part P00055-1 onto part P00019 (FIG.1) and thread the assembly onto the valve. The remaining parts in the kit can be cut to fit based on the depth the valve is in the wall. This extension kit can cover up to 0.845" into the wall.

-REPLACES-
SA255 FOR SA255-1 TH-7000-3 FOR TH-7000-2 PM-5-4X FOR PM-5-4X-1

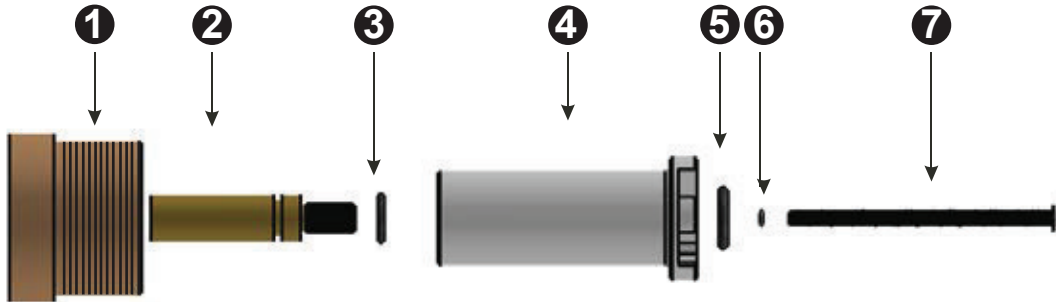

ITEM NO.	PART NUMBER	DESCRIPTION	QTY.
1	P00055-1	Threaded Sleeve Extension	1
2	SA255-1	Broach for TH-7000 Extension Kit	1
3	PM-1215	O-Ring for SA255-1	1
4	TH-7000-2	Plastic Temperature Restrictor for TH-7000 Extension Kit	1
5	PM-1216	O-ring for TH-7000-2	1
6	PM-344	O-ring	1
7	PM-5-4X-1	Screw for TH-7000 Extension Kit	1

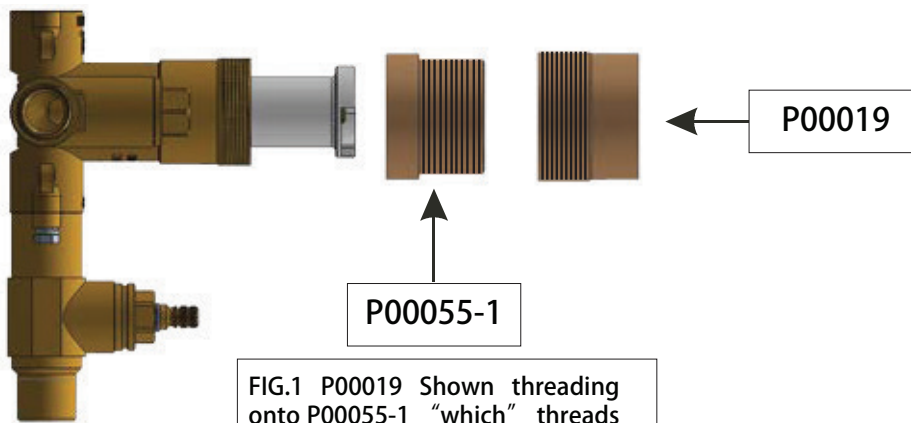
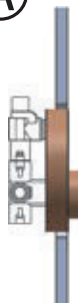

FIG.1 P00019 Shown threading onto P00055-1 "which" threads onto the valve (TH-8000/8200/8300)

INSTALLATION INSTRUCTIONS

(A)



-Rough in the valve, orienting the mud guard (2) flush with the finish wall (You can recess up to 1/4").

(B)

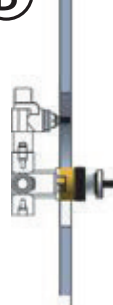

-Remove the plastic mud guard (2).

(C)



-Screw the all thread extension (4) onto the volume control / diverter valve until it stops.

-Screw on the thermostatic threaded sleeve (11) and put the broach extension (10) onto the thermostatic stem.

(D)



- Align the two holes of the plate (3) over the valve, with the smaller hole on top against the wall.

- Push the diverter ring (6) over the upper hole of the plate with the "OFF" sign on top.

- Thread the On/Off handle assembly (7) over the all thread (4). Mark off excess, remove the all thread extension and trim plate, and cut thread extension length to fit.

(E)



-Put the diverter broach extension (5) onto the volume control /diverter valve.

-Repeat step D for the broach extension.

-Replace the newly cut diverter broach extension and all thread extension (4) back onto the valve.

(F)



-Replace the plate (3) and diverter ring (6).

-Hand tighten the thermostatic flange (12) to the threaded sleeve (11).

-Place the On/Off handle assembly(7) onto the diverter broach extension (5) and hand tighten the escutcheon. Make sure lever is oriented up towards the 12' o'clock position.

(G)



-Insert the thermostatic dial (14) with the "100" mark oriented upwards to the 12 o'clock position over the extension broach(10).

-Secure with the provided long screw (15) and cut excess length to fit Assemble the thermostatic handle (16) onto the thermostatic dial and tighten with the the set screw (9) ensuring the handle faces the 6 o' clock position.

INSTALLATION INSTRUCTIONS

General characteristic

- Santec thermostatic valve is suitable for most water heater systems provided it is installed correctly
- Low pressure storage heaters are not recommended for this application

Cartridge Cleaning

After years of use, impurities and lime scale can restrict the water flow. To clean the cartridge, please follow these instructions:

- 1- Remove the handle screw, handle trim, trim plate screws, and trim plate.
- 2- Shut off the water line by turning the check valve shut off mechanism clockwise. Make sure that the both hot and cold sides are closed.
- 3- Remove the cartridge using a 30mm wrench.
- 4- Wash the filter under running water or soak it with vinegar or a descaling agent.
- 5- Reassemble the cartridge making sure that the blue lines on the cartridge are aligned.
- 6- Open the check valve shut-off mechanism, turn on the water, and check water flow.
- 7- If the water flow is normal, reassemble the trims.

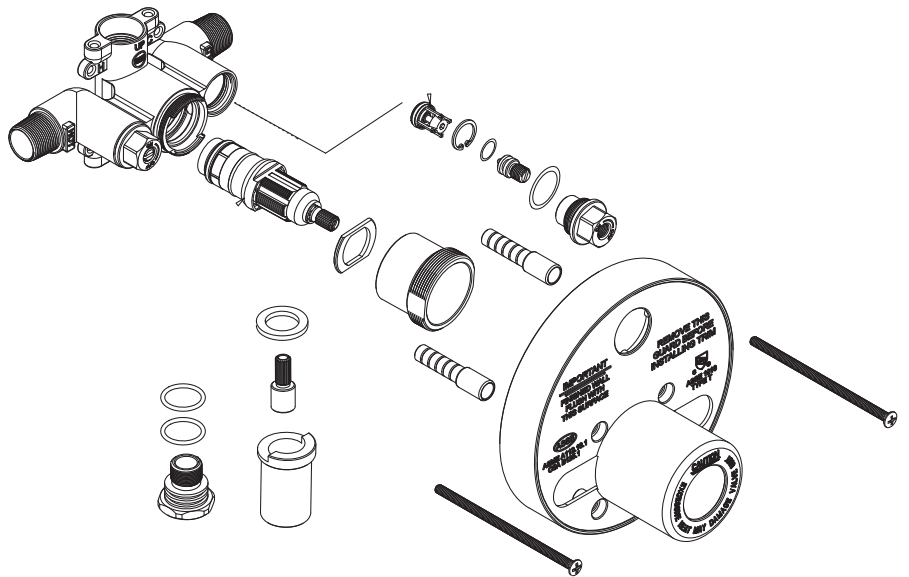

IF THE ACTUAL WATER TEMPERATURE IS DIFFERENT FROM THE DIAL :

- 1- Remove the thermostatic handle with the provided Allen key
- 2- Turn the water on through the volume control and measure the actual water temperature with a regular thermometer.
- 3- Turn the dial until the thermometer shows 100F.
- 4- Remove the dial handle from the valve.
- 5- Align the 100F with the center mark of the valve cylinder, replace screw and tighten.
- 6- Insert the handle into the cartridge
- 7- Tighten the handle screw with provided Allen key.

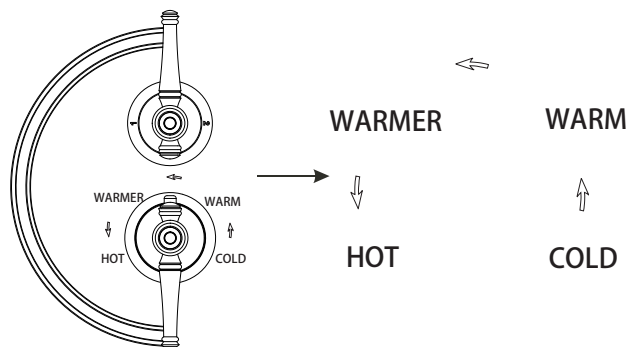



LIFETIME LIMITED WARRANTY

SANTEC is committed to enhancing your bathroom experience by creating luxury products that will provide enduring satisfaction. Every effort has been made to satisfy the highest standards of design and production to create lasting peace of mind for our customers. Proof of purchase must be provided for all warranty claims, SANTEC provides the following limited warranties on our product.

LENGTH OF WARRANTY & WHO IS COVERED BY OUR WARRANTY

This warranty only extends to the original consumer purchaser.

WHAT IS COVERED BY OUR WARRANTY

1. **Finishes:** SANTEC Polished Chrome, Polished Nickel and Satin Nickel finishes carry a Lifetime Limited warranty against manufacturing defects and tarnish to the original purchaser. Custom finishes carry a ten (10) years limited warranty against manufacturing defects and tarnish to the original purchaser only. Kitchen products carry a three (3) year limited warranty.
2. **Cartridges:** Santec cartridges carry a lifetime limited warranty, with the exception of thermostatic and pressure balanced cartridges, which carry a three (3) year limited warranty against manufacturing defects to the original purchaser.
3. **Parts:** Santec parts carry a ten (10) year limited warranty against manufacturing defects, to the original purchaser. Kitchen products carry a five (5) year limited warranty.

EXCLUSIONS AND LIMITATIONS OF WARRANTY

This warranty does not cover:

1. **Drains**
2. **Crystals and/or glass**
3. Damage due to negligence, accident, abuse, improper installation, or improper maintenance such as, but not limited to: heat from soldering during installation, the use of plumber's putty, damage from tools used during installation, the use or exposure to chemicals or cleaning products either abrasive or non-abrasive, or the use of any cleaning tool or product other than a soft, clean cloth. Reverse osmosis may also shorten the life of the finish.
4. Changes in the finish or in the product due to normal wear or aging does not cover any products or parts which have been altered or used in a manner not typical for the product.
5. Loss, damages, or expense, incidental or consequential whatsoever, originating from the purchase, installation, use, repair, failure, or replacement of any SANTEC product or part, allowed by law.
6. Commercial and/or Industrial installations and use of the product.
7. This warranty does not include labor, travel charges, or any costs incurred for repair, removal, installation, servicing, diagnosing, or handling of either defective or replacement parts. Changes in the finish or in the product due to normal wear or aging does not cover any products or parts
8. Access should be provided to the roman tub valves for future service or repair to valves and piping. Under no circumstances will Santec Faucet, Inc. be liable for any costs associated with the removal of materials for future access to the tub valves or piping for service or repair.
- 9.

This warranty does not cover: damage due to negligence, accident, abuse, improper installation, or improper maintenance such as, (but not limited to): heat from soldering during installation, the use of plumbers putty, damage from tools used during installation, the use or exposure to chemical or cleaning products, abrasive or non-abrasive, or the use of any cleaning tool or product other than a soft, clean cloth. **This warranty does not cover: changes in the finish or in the product due to normal wear or again and does not cover any product or parts which have been altered or used in a manner not typical for the product.** Santec will not be held liable for damage to products caused by the freight carrier, any such claims should be made immediately with the freight carrier. This warranty does not cover any cost involved in the installation, repair, or replacement of any SANTEC product or parts. This warranty does not cover and SANTEC will not be held liable for any loss, damages, or expenses, incidental or consequential whatsoever, originating from the purchase, installation, use, repair, failure, or replacement of any SANTEC product or part, as allowed by law. The product of components of the covered product will either be repaired, refinished or replaced at the sole discretion of SANTEC. SANTEC reserves the right to examine any product claimed defective prior to any warranty claim being accepted or processed, at its sole discretion. This warranty gives you specific legal rights and you may have other rights which may vary from state to state.

Effective: 05/01/2015



FINISH CARE INFORMATION

WARNING: Do not clean your SANTEC product with ammonia (window cleaner), bleach, soaps, acids, abrasives, harsh polishes, harsh cleaners, a coarse surfaced cloth, coarse sponge, or any type of scouring pad. Doing so may ruin your faucet finish and/or void the warranty.

Thank you for making SANTEC a part of your lifestyle and luxury spa experience. Our products have been created as works of enduring quality and sophisticated design. Luxurious finishes need proper care and attention, so in order to understand how to properly clean your distinctive luxury finish, please refer to the finish care information below:

Your SANTEC product can be identified in one of two categories: clear coated finishes or non-clear coated finishes. Clear coated finishes are more scratch-sensitive and are more reactant to harsh cleaning chemicals than non-clear coated finishes. Once you have identified the specific luxury finish of your SANTEC product, please follow the important corresponding care instructions.

Living finishes are unique, are intended to change over time and are excluded from the finish warranty. Any product outdoors or in a marine environment are excluded from the finish warranty.

CLEAR COATED FINISHES

Clear Coated Finishes are as Follows:

We recommend that all faucets, drains, etc., be gently wiped dry with a soft cloth after use to avoid water spotting and water deposit build-up. A mild liquid hand soap may be used occasionally if desired. Use of a non-abrasive carnauba wax will add protection to the finish and should be used if the faucets will not be dried after use. Santec Orobrass kitchen products are clear coated. For clear coated finishes, it is recommended to clean your product weekly with a soft moist cloth.

NON-CLEAR COATED FINISHES

We recommend that all faucets, drains, etc., be gently wiped dry with a soft cloth after use to avoid water spotting and water deposit build-up. A mild liquid hand soap may be used occasionally if desired. Use of a non-abrasive carnauba wax is occasionally required and will add protection to the finish if the faucets will not be dried after use.

TO OBTAIN WARRANTY SERVICE

Please read 'WHAT IS COVERED BY OUR WARRANTY' and 'EXCLUSIONS AND LIMITATIONS OF WARRANTY' sections to understand what is and what is not covered. Please have ready the proof of purchase (original sales receipt), description of the problem, and carefully package the product or defective part with postage prepaid. Then, please contact your local SANTEC Showroom or write to SANTEC Technical Services.



3501 Challenger Street
Torrance, CA 90503
www.santecfaucet.com

Phone. 310.542.0063
Fax. 310.542.5681

Effective: 05/01/2015