

Please read the instructions completely before beginning the installation.

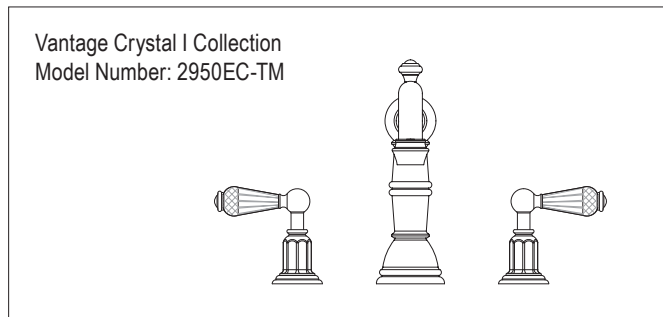
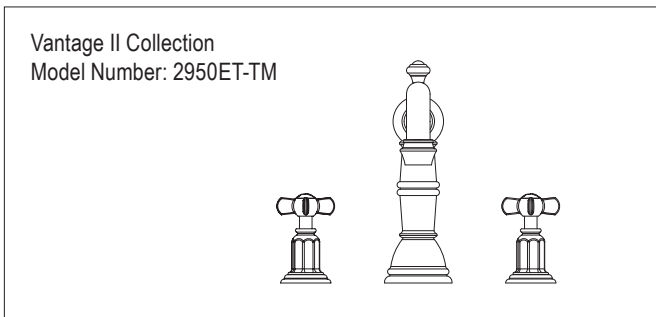
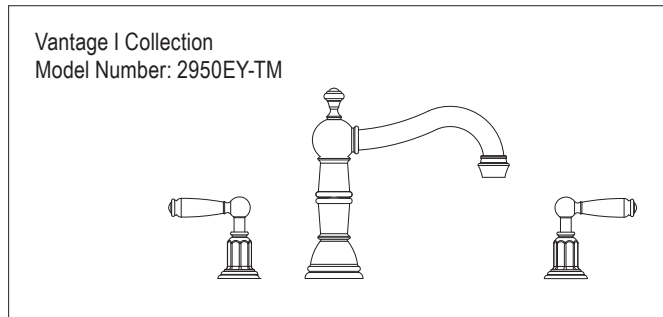
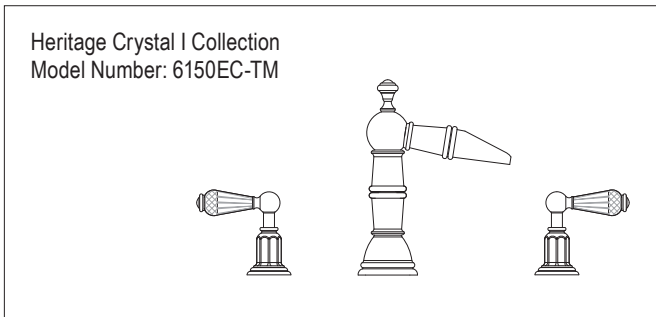
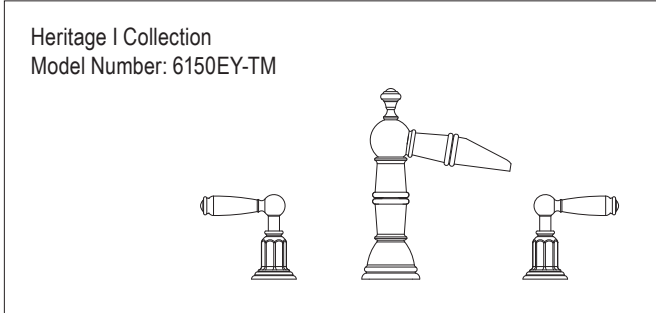

Flush both supply lines before installation, then shut off both supply lines.
 Minimum hole size for the spout and handle trim is 1-1/4" and maximum of 1-1/2"

HANDLE TRIM INSTALLATION

- 1 -Unscrew pre-assembled handle trim from the valve body. Hot valve assembly "Red" to be mounted on left. Cold valve assembly "Blue" to be mounted on right.

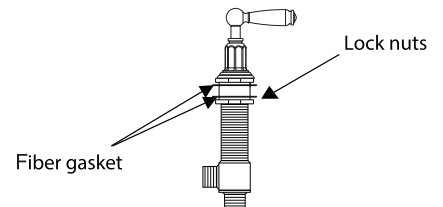

The measurements shown are for reference only. Products and specifications shown are subject to change without notice.

www.santecfaucet.com | P: 310.542.0063 F: 310.542.5681

- 2** - Remove the top lock nut and the fiber gasket from the valve body.
 - Apply a ring of silicone caulking around the handle hole on deck top.

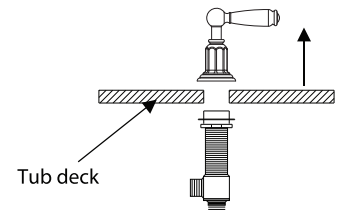

- 3** - Slip valve body up from below tub deck.
 Place the top lock nut and the fiber gasket back onto the valve body until the top surface of the lock nut is flush with the top surface of the valve body.
 - Secure the top lock nut in place before inserting the handle.

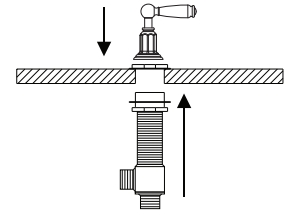

- 4** - Align handles with respect to the spout and tighten bottom lock nut until secure.

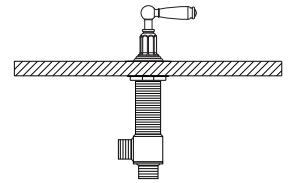

SPOUT TRIM INSTALLATION

- 1** - Remove the tee connector and spout mounting hardware from quick connect shank being sure to leave on brass plate.
- 2** - Apply a ring of silicone caulking around hole designated for spout.
 - DO NOT USE PLUMBERS' PUTTY, WHICH CAN DAMAGE FINISH.
- 3** - From the top of the deck, slip the quick connect shank through the assigned spout hole.
- 4** - Secure the quick connect shank by putting the washer and lock nut back on the shank. Tighten the lock nut firmly.
- 5** - From the top of the deck, slip the spout with the flange and flange washer onto the quick connect shank top. Align the spout and tighten the set screw with the Allen key provided.
- 6** - Connect the tee connector to the spout shank.

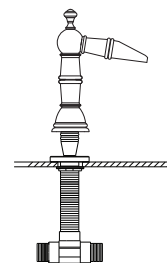
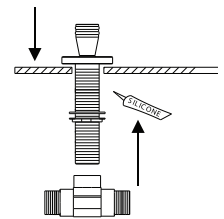

The measurements shown are for reference only. Products and specifications shown are subject to change without notice.

www.santecfaucet.com | P: 310.542.0063 F: 310.542.5681

PARTS DRAWING

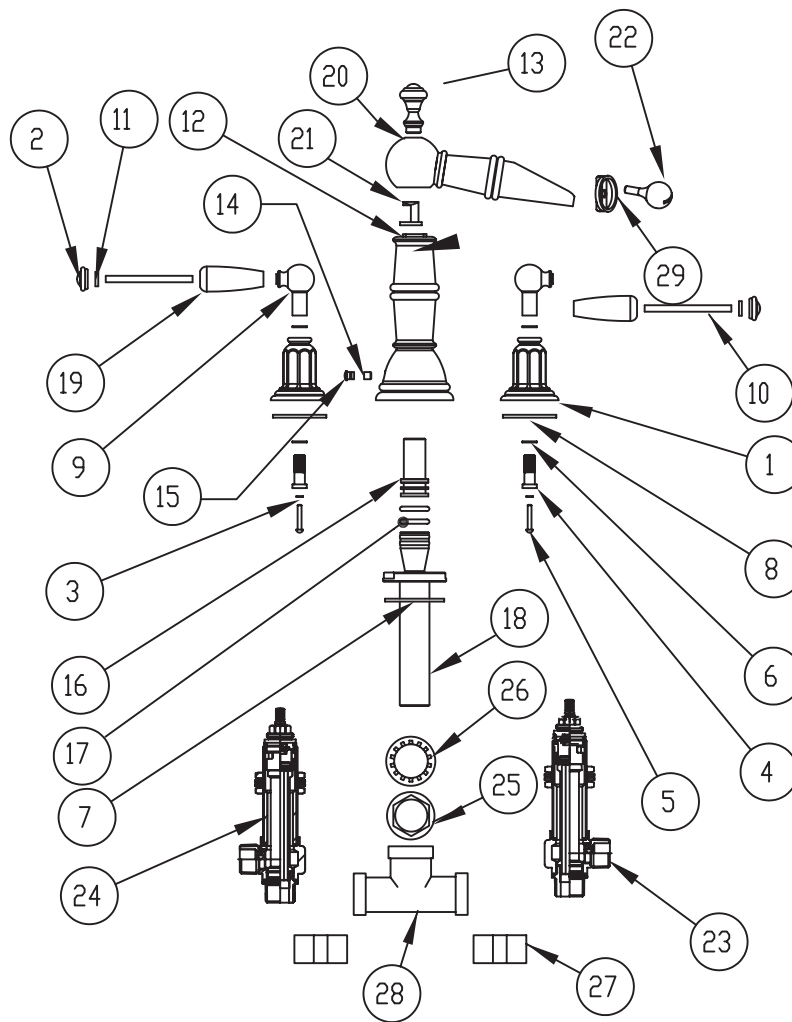

#	PART DESCRIPTION	PART #
1	Vantage Widespread Bell	PA3021
2	Vantage End Cap	PA3023
3	Washer	PM-184
4	Insert Stem for E/S	SA240
5	Screw	PM-181
6	Teflon Washer for Insert	PM-099
7	Rubber Gasket for Handle Flanges	PM-400
8	Rubber O-Ring	PM-407
9	Vantage Post for Metal Lever	PA3020
10	Lever Rod	PM-976
11	Wahser for Crystal Lever	PM-243
12	Heritage Roman Tub Base	PS-5VT00-U-3
13	Vantage R/T Head Knob	P0335
14	Set Screw	PM-024
15	Cover Plug	P0257

#	PART DESCRIPTION	PART #
16	Metropoli R/T Spout Tube Connector	PA3014
17	Rubber O-Ring for Quickconnect Shank	PM-613
18	Quick Connect Shank	KQ-5100B
19	Vantage Metal Lever	PA3025
20	Heritage Roman Tub Head and Spout	PS-3VT00-U
21	Roman Tub Back Flow	PM-967
22	Ball Flow Regulator	PM-969
23	Valve 3/4" Cold	P0496
24	Valve 3/4" Hot	P0495
25	Bross Nut	PM-550
26	Crimped Metal Waher	PM-551
27	3/4" X 1-1/2" Brass Nipple	P0341
28	3/4 Tee Connector	P0340
29	Ring Flow Regulator	PM-968

* Please specify the finish when ordering the part.

The measurements shown are for reference only. Products and specifications shown are subject to change without notice.

www.santecfaucet.com | P: 310.542.0063 F: 310.542.5681

SPECIFICATION SHEETS

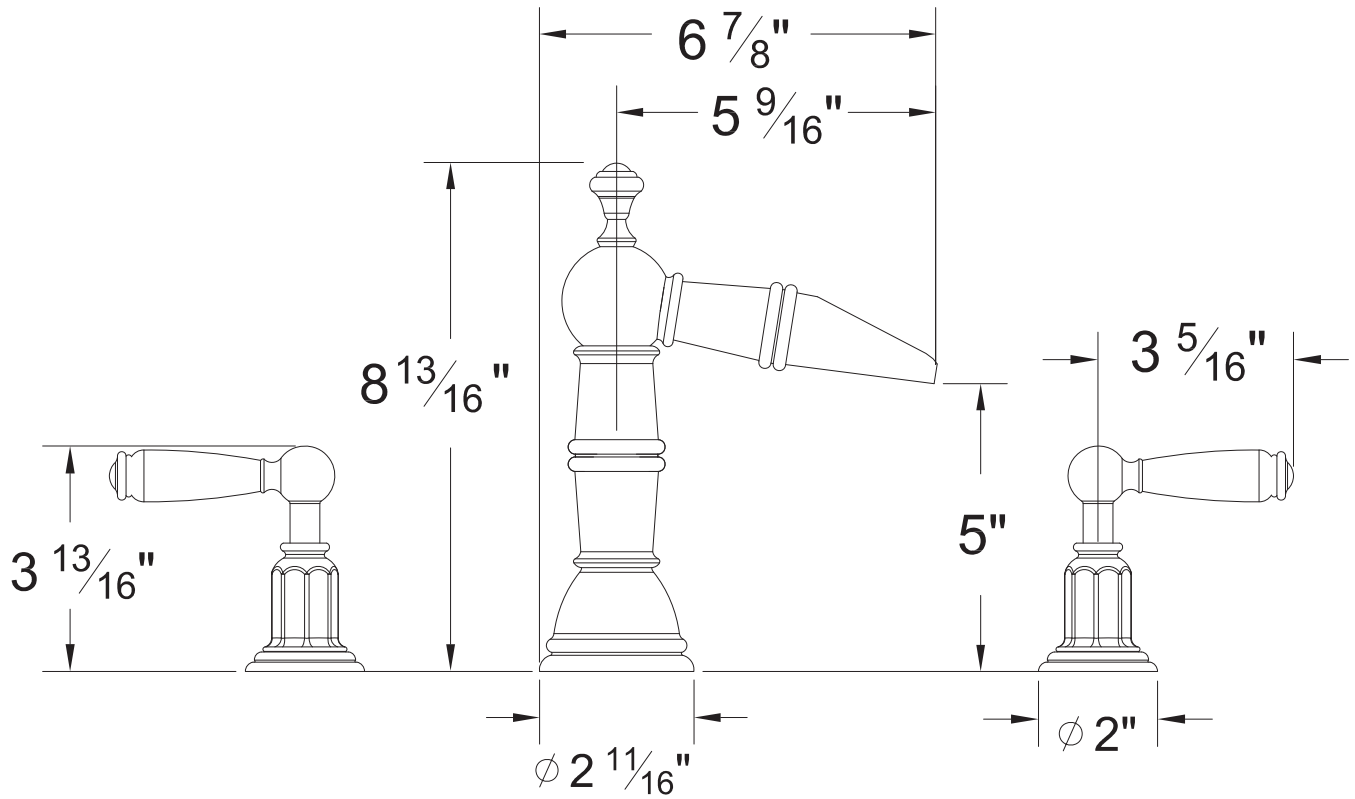

The measurements shown are for reference only. Products and specifications shown are subject to change without notice.
www.santecfaucet.com | P: 310.542.0063 F: 310.542.5681



FINISH CARE INFORMATION

WARNING: Do not clean your SANTEC product with ammonia (Window cleaner), bleach, soap, acids, abrasives, harsh polish, harsh cleaners, a coarse surfaced cloth, coarse sponge, or any type of scouring pad. Doing so may ruin your faucet finish and/or void the warranty.

Thank you for making SANTEC a part of your lifestyle and luxury spa experience. Our products have been created as works of enduring quality and sophisticated design.

Luxurious finishes need proper care and attention, so in order to understand how to properly clean your distinctive luxury finish, please refer to the finish care information below:

Your SANTEC product can be identified in one of two categories: clear coated finishes or non-clear coated finishes. Clear coated finishes are more scratch-sensitive and are more reactant to harsh cleaning chemicals than non-clear coated finishes. Once you have identified the specific luxury finish of your SANTEC product, please follow the important corresponding care instructions.

CLEAR COATED FINISHES

We recommend that all faucets, drains, etc., be gently wiped dry with a soft cloth after use to avoid water spotting and water deposit build-up. A mild liquid hand soap may be used occasionally if desired. Use of a non-abrasive carnauba wax will add protection to the finish and should be used if the faucets will not be dried after use. For clear coated finishes, it is recommended to clean your product weekly with a soft moist cloth.

NON-CLEAR COATED FINISHES

We recommend that all faucets, drains, etc., be gently wiped dry with a soft cloth after use to avoid water spotting and water deposit build-up. A mild liquid hand soap may be used occasionally if desired. Use of a non-abrasive carnauba wax is occasionally required and will add protection to the finish if the faucets will not be dried after use.

TO OBTAIN WARRANTY SERVICE

Please read 'WHAT IS COVERED BY OUR WARRANTY' and 'EXCLUSIONS AND LIMITATIONS OF WARRANTY' sections to understand what is and what is not covered. Please have ready the proof of purchase (original sales receipt), description of the problem, and carefully package the product or defective part with postage prepaid. Then, please contact your local SANTEC Showroom or write to SANTEC Technical Services.



LIFETIME LIMITED WARRANTY

SANTEC is committed to enhancing your bathroom experience by creating luxury products that will provide enduring satisfaction. Every effort has been made to satisfy the highest standards of design and production, to create lasting peace of mind for our customers. We provide the following limited warranties on our products:

LENGTH OF WARRANTY & WHO IS COVERED BY OUR WARRANTY

This warranty extends to the original consumer purchaser only and extends for as long as the original purchaser owns the product and the home in which the product is installed.

WHAT IS COVERED BY OUR WARRANTY

1. **FINISHES:** SANTEC Polished Chrome, Polished Nickel and Satin Nickel finishes carry a Lifetime Limited warranty against manufacturing defects and tarnish to the original purchaser. All other finishes carry a ten (10) year limited warranty against manufacturing defects and tarnish to the original purchaser only.
2. **CARTRIDGES:** Santec cartridges carry a lifetime limited warranty, with the exception of thermostatic and pressure balanced cartridges, which carry a three (3) year limited warranty against manufacturing defects to the original purchaser.
3. **PARTS:** Santec parts carry a 10-year limited warranty against manufacturing defects, to the original purchaser.

EXCLUSIONS & LIMITATIONS OF WARRANTY

This warranty does not cover:

1. Damage due to negligence, accident, abuse, improper installation, or improper maintenance such as, but not limited to: heat from soldering during installation, the use of plumber's putty, damage from tools used during installation, the use or exposure to chemicals or cleaning products either abrasive or non-abrasive, or the use of any cleaning tool or product other than a soft, clean cloth. Reverse osmosis may also shorten the life of the finish.
2. Changes in the finish or in the product due to normal wear or aging does not cover any products or parts which have been altered or used in a manner not typical for the product.
3. Loss, damages, or expense, incidental or consequential whatsoever, originating from the purchase, installation, use, repair, failure, or replacement of any SANTEC product or part, allowed by law.
4. Commercial and/or Industrial installations and use of the product.
5. This warranty does not include labor, travel charges, or any costs incurred for repair, removal, installation, servicing, diagnosing, or handling of either defective or replacement parts.
6. Damage or deterioration caused by environmental impacts.

SANTEC reserves the product components of the covered product will be repaired, refinished, or replaced at the sole discretion of SANTEC. SANTEC reserves the right to examine any product claimed defective prior to any warranty claim being accepted or processed, at its sole discretion. This warranty gives you specific legal rights and you may have other rights which may vary from state to state.

The measurements shown are for reference only. Products and specifications shown are subject to change without notice.

www.santecfaucet.com | P: 310.542.0063 F: 310.542.5681