

FEATURED MODEL

519594 Elevated Rim, 10" bowl depth

FEATURES

- Winner of the 2013 RED DOT Award for design
- Crafted by hand in Germany
- A new elevated rim design with a solid appearance giving it a strong architectural and distinguishing character
- BLANCO R10 inside bowl corners offer the optimal mix of beauty and wasy to clean function.
- Sound-deadening pads inspired by luxury automotive technology
- Required outside cabinet: 30"
- 18 gauge, 304 series stainless steel
- 18/10 chrome/nickel content
- Satin Polished Finish
- Rear drain placement



NOMINAL DIMENSIONS

Model 519594 shown

OVERALL	BOWL DEPTH	DRAIN
26-3/4" x 17-3/4"	10"	3-1/2"

DXF cutout templates available on our website.

OPTIONAL ACCESSORIES

Stainless Steel Grid: 231167

Cutting Board: 232120

BLANCO CAPFLOW: 517666

CODE/STANDARDS COMPLIANCE

ASME 112.19.3-00

IAPMO/UPC listed

WARRANTY

Blanco America's STEELART™ sinks feature a LIMITED LIFETIME WARRANTY to be free of all manufacturing defects under normal use. See our complete warranty for details.

While Blanco America endeavors to provide accurate information, all dimensions are nominal, cannot be guaranteed, and are subject to change or cancellation. Blanco America assumes no responsibility for use of superseded or voided specifications.

JOB INFORMATION

Job Name: _____

Contact: _____

Date Specified: _____

Specifier: _____

Contractor: _____

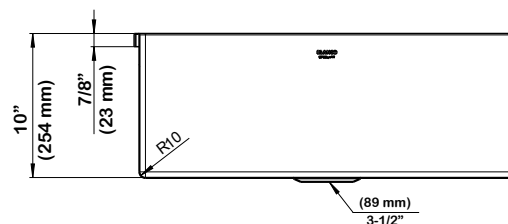
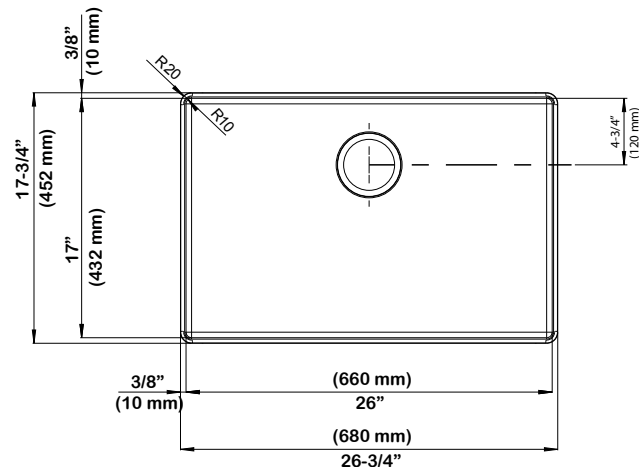

INSTALLATION AND CUT OUT NOTE:

ATTIKA features a unique underside clip systems which requires a precise cut out. USE OF DXF FILES OR TEMPLATES IS STRONGLY SUGGESTED.

BLANCO AMERICA

800.451.5782

www.blancoamerica.com

© 2013 BLANCO AMERICA

12/13

SPEC-003