

5

4

3

2

1

E

E

D

D

C

C

B

B

ITEM NO.	PART NUMBER	DESCRIPTION	QTY.
1	3-157/00	WALL TUB SPOUT, P26001 (D1205X3) DORALFE, 3RING	1
1.1	P26001/00	DORALFE WALL TUB SPOUT	1
1.2	P03061	#CH-101-6 PLTC WTR STNR FOR SPOUT	1
1.3	P26018/00	ESCUTCHEON BASE, 3RING WALL SPOUT	1

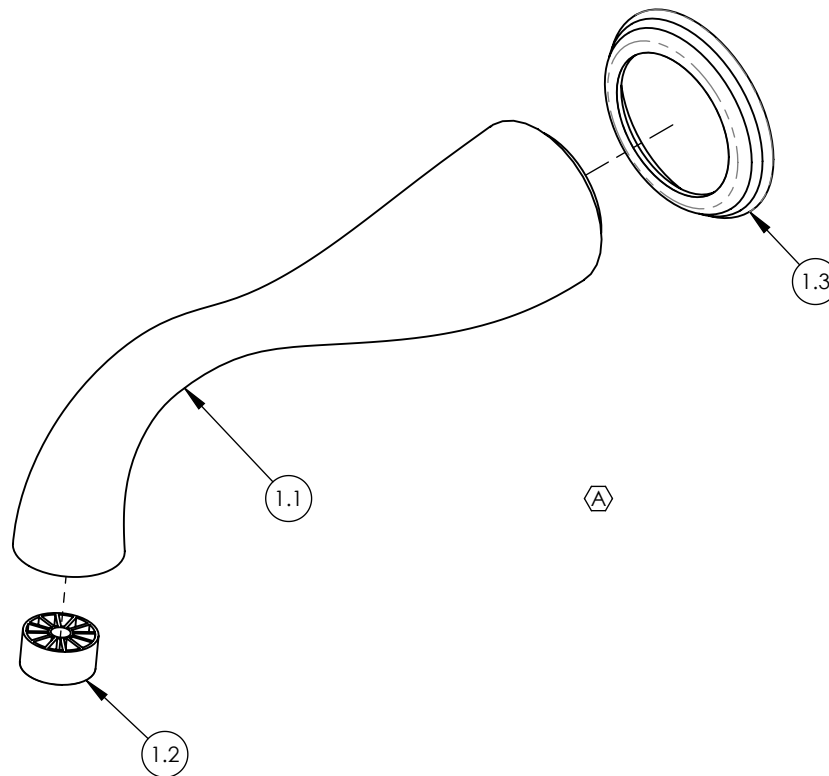

ALL	REV.	DESCRIPTION	DATE	APPROVED
A		UPDATE TEMPLATE, ADD SUBASSY & 2ND SHEET	6/22/2020	AMM

1261 LOGAN AVENUE
COSTA MESA, CALIFORNIA 92626
PHONE: 714.361.4800
FAX: 714.617.3120

PHYLIRICH[®]
Defining Luxury Since 1959

PROPRIETARY AND CONFIDENTIAL
THE INFORMATION CONTAINED IN THIS DRAWING IS THE SOLE PROPERTY OF PHYLIRICH. ANY REPRODUCTION IN PART OR AS A WHOLE WITHOUT THE WRITTEN PERMISSION OF PHYLIRICH IS PROHIBITED.

-	-	INTERPRET GEOMETRIC DIMENSIONING & TOLERANCING IN ACCORDANCE WITH ASME Y14.5-2009 & ASME Y14.41-2003 STANDARDS, UNLESS OTHERWISE SPECIFIED. DIMENSIONS ARE IN INCHES. TOLERANCES ARE:		
-	-			
-	-			
NEXT ASSY	USED ON	FRACTIONS ±1/16"	DECIMALS X.X: ±.1 X.XX: ±.01 X.XXX: ±.005	ANGULAR ±2°
APPLICATION				
MATERIAL			NAME	DATE
FINISH		DRAWN	CA	10/21/2013
DO NOT SCALE DRAWING		CHECKED		

WALL TUB SPOUT, REVERE & SAVANNAH

SIZE **A** ASM/PRT NO. D1100X3/00 REV A

SCALE: 1:2 WEIGHT: lbs. SHEET 1 OF 2

5

4

3

2

1

A

A

5

4

3

2

1

E

E

D

D

C

C

B

B

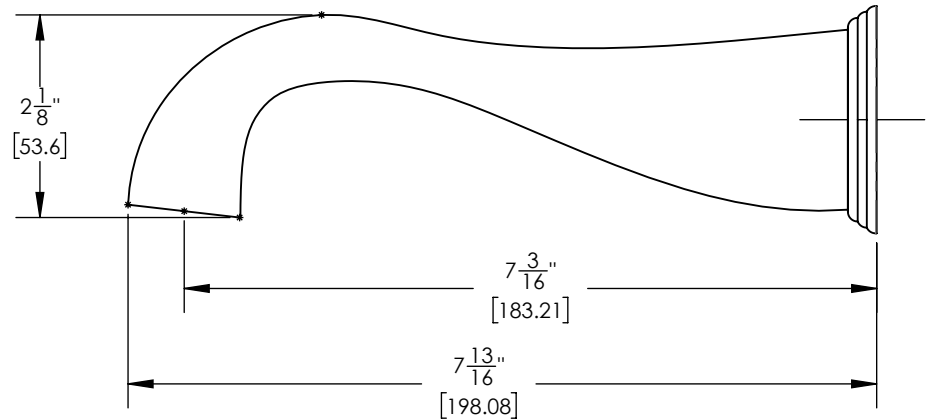
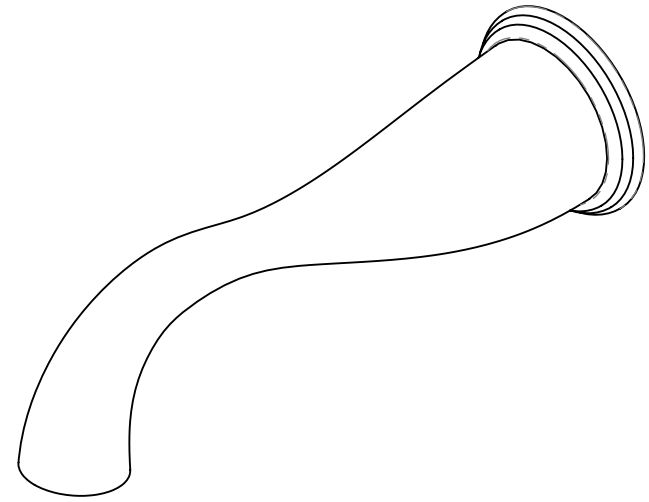
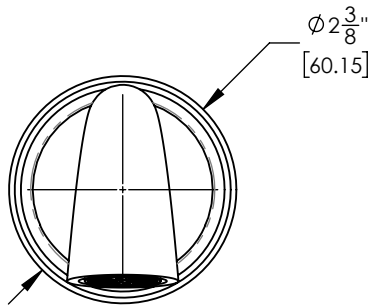

A

A

1261 LOGAN AVENUE
COSTA MESA, CALIFORNIA 92626
PHONE: 714.361.4800
FAX: 714.617.3120

PHYLIRICH[®]
Defining Luxury Since 1959

PROPRIETARY AND CONFIDENTIAL
THE INFORMATION CONTAINED IN THIS DRAWING IS THE SOLE PROPERTY OF PHYLIRICH. ANY REPRODUCTION IN PART OR AS A WHOLE WITHOUT THE WRITTEN PERMISSION OF PHYLIRICH IS PROHIBITED.
DO NOT SCALE DRAWING

WALL TUB SPOUT, REVERE & SAVANNAH

SIZE A	ASM/PRT NO. D1100X3/00	REV A
SCALE: 1:2	WEIGHT: lbs.	SHEET 2 OF 2

5

4

3

2

1