

HIALEAH I – BUILDERS' CHOICE

inches (mm)

60 x 42 x 23 ½ (1525 x 1065 x 595) • Fax on Demand #5047

SOAKER MODEL #6260620

WHIRLPOOL MODEL #6260621



AQUATIC ADVANTAGE

- National distribution
- 6 manufacturing facilities
- Private fleet
- Centralized customer service
- Field support
- 24-hour fax-on-demand

FEATURES (ALL MODELS)

- Slip-resistant floor
- Pre-leveled base
- Lucite® cast acrylic surface
- Limited 10- year warranty
- UL and IAPMO listed

OPTIONS

- Comfort pillow:
Biscuit, Black, White
- 1.5kW inline maintenance heater
(whirlpool only)
- Bolt-on grab bar(s):
Chrome, Oil-Rubbed Bronze,
Polished Brass, Brushed Nickel,
Color Matched (Biscuit, White)
- Cable drive waste & overflow:
Chrome, Oil Rubbed Bronze,
Polished Brass, Brushed Nickel,
Color Matched (Biscuit, Bone, White)
- Lift & turn waste & overflow:
Chrome, Oil Rubbed Bronze,
Polished Brass, Brushed Nickel
- Tile flange
- Optional pump location
- Acrylic skirt

COLOR & TRIM OPTIONS

Stock

Almond (C)
Bone (C)
Biscuit (C)
White (C)

C = Color Matched Trim

AVAILABLE SYSTEM

WHIRLPOOL

- 8 whirlpool hydrotherapy jets including:
 - High-flow directional jets
 - Low-profile spinning micro-jets
- .75 hp pump
- Pneumatic on/off control
- Advanced safety suction system
- Factory run-tested



AQUATIC

Where Inspiration Takes Shape

HIALEAH I

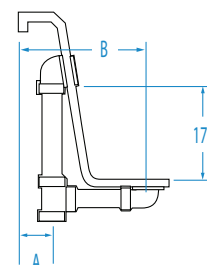
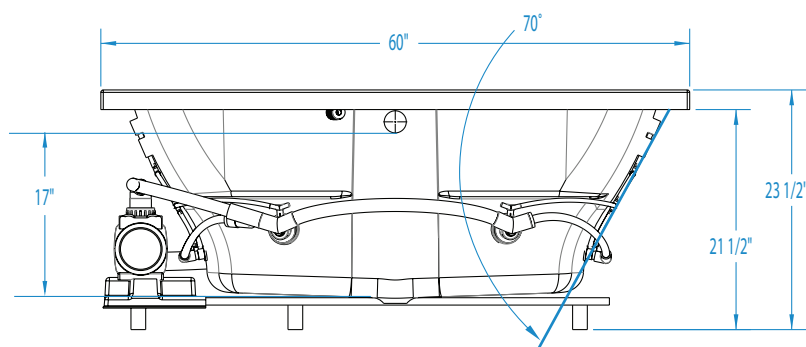
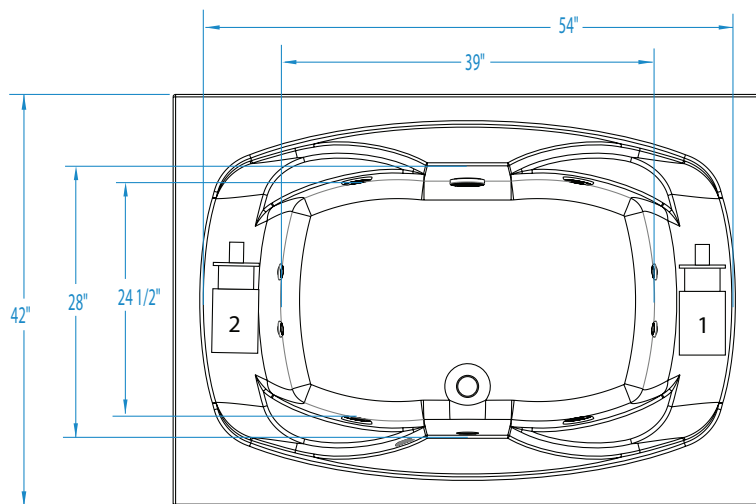
 60 x 42 x 23 1/2 (1525 x 1065 x 595)
 inches (mm)

FEATURES lbs (kg) Dimensional Tolerance ± 3/8". Dimensions needed for site preparation should be measured from the unit. Aquatic assumes no responsibility for preparatory work.

Type and Model #	Material	Jets	Pump	Air System	Heater	Controls	Drain	Pkg. Wt.
Soaker #6260620	Acrylic	0	-	-	-	-	Center Front	115 (52)
Whirlpool #6260621	Acrylic	8	0.75 HP	-	1.5kW inline (optional)	Pneumatic	Center Front	167 (76)

DIMENSIONS inches (mm)

Width Overall / Net	Depth Overall / Net	Height Overall / Net	Skirt Height
60 (1525)	42 (1065)	23 1/2 (595)	-

SUMP DATA inches (mm)

Capacity to Overflow gal (ltr)	Min. Operating Capacity gal (ltr)	WIDTH @ centerline		DEPTH @ centerline	
		Top	Bottom	Top	Bottom
66 (250)	44 (167)	54 (1370)	39 (990)	28 (710)	24 1/2 (620)

PLUMBING DIMENSIONS inches (mm)

A	B	Drain to Overflow	Drain Diameter / Clearance
6 1/4 (160)	10 3/4 (275)	17 (430)	2 (50) / 1 1/4 (30)

ELECTRICAL DATA

Component	Specification	Requirement
Pump	.75 HP; 5 AMP; 120 V	15 AMP; 120V, separate circuit; Class A GFCI
Optional Heater (whirlpool model)	1.5KW; 12 AMP; 120 V	15 AMP; 120V, separate circuit; Class A GFCI

NOTES:

1) Where applicable, utilize cut-out templates packed with unit for deck cutouts.

2) 16 x 16 (405 x 405) minimum access required at pump/blower location(s).