

COOPER 30 – BUILDERS' CHOICE TUB

inches (mm)

60 x 30 x 22 ¾ (1525 x 760 x 575) • Fax on Demand #1350

SOAKER MODEL #9460600Q

WHIRLPOOL MODEL #9460601Q



AQUATIC ADVANTAGE

- National distribution
- 6 manufacturing facilities
- Private fleet
- Centralized customer service
- Field support
- 24-hour fax-on-demand

FEATURES (ALL MODELS)

- Extended skirt (AFR)
- Integral tile flange
- Slip-resistant floor
- Pre-leveled base
- Lucite® cast acrylic surface
- Limited 10- year warranty
- UL and IAPMO listed

OPTIONS

- Comfort pillow:
Biscuit, Black, White
- 1.5kW inline maintenance heater
(whirlpool only)
- Bolt-on grab bar(s):
Chrome, Oil-Rubbed Bronze,
Polished Brass, Brushed Nickel,
Color Matched (Biscuit, White)
- Cable drive waste & overflow:
Chrome, Oil Rubbed Bronze,
Polished Brass, Brushed Nickel,
Color Matched (Biscuit, Bone, White)
- Lift & turn waste & overflow:
Chrome, Oil Rubbed Bronze,
Polished Brass, Brushed Nickel
- Cut skirt (19")

COLOR & TRIM OPTIONS

Stock

Almond (C)
Bone (C)
Biscuit (C)
White (C)

C = Color Matched Trim

AVAILABLE SYSTEM

WHIRLPOOL

- 8 whirlpool hydrotherapy jets including:
 - High-flow directional jets
 - Low-profile spinning micro-jets
- .75 hp pump
- Pneumatic on/off control
- Advanced safety suction system
- Factory run-tested

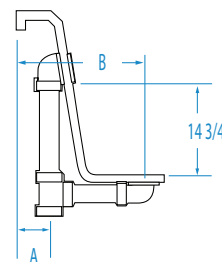
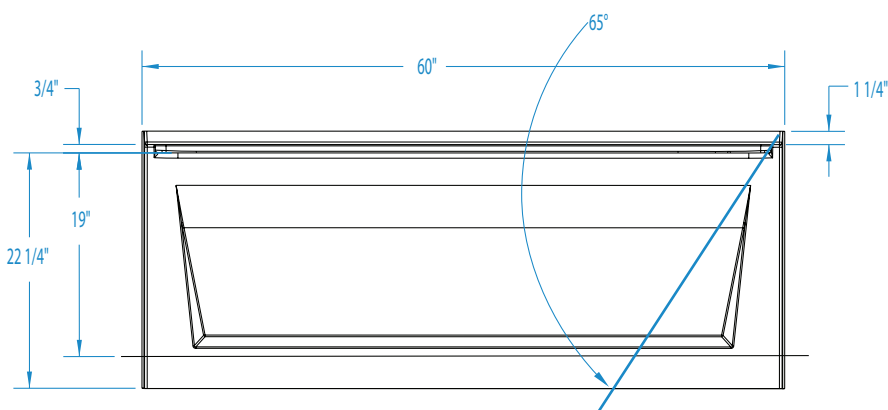
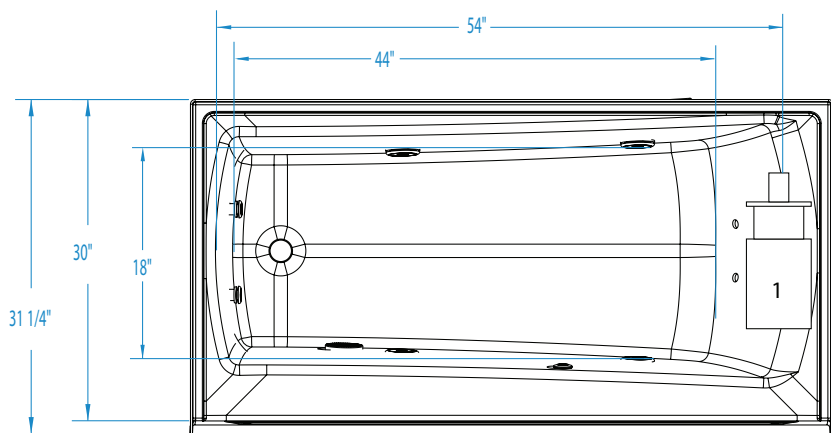

COOPER 30

 60 x 30 x 22 3/4 (1525 x 760 x 575)
 inches (mm)

FEATURES lbs (kg) Dimensional Tolerance $\pm 3/8"$. Dimensions needed for site preparation should be measured from the unit. Aquatic assumes no responsibility for preparatory work.

Type and Model #	Material	Jets	Pump	Air System	Heater	Controls	Drain	Pkg. Wt.
Soaker #9460600Q	Acrylic	0	–	–	–	–	LH or RH	113 (52)
Whirlpool #9460601Q	Acrylic	8	0.75 HP	–	1.5kW inline (optional)	Pneumatic	LH or RH	163 (74)

DIMENSIONS inches (mm)

Width Overall / Net	Depth Overall / Net	Height Overall / Net	Skirt Height
60 (1525)	31 1/4 (795) / 30 (760)	24 1/4 (615) / 22 3/4 (575)	22 (560)

SUMP DATA inches (mm)

Capacity to Overflow gal (ltr)	Min. Operating Capacity gal (ltr)	WIDTH @ centerline		DEPTH @ centerline	
		Top	Bottom	Top	Bottom
56 (212)	31 (117)	54 (1372)	44 (1118)	22 1/4 (565)	18 (457)

PLUMBING DIMENSIONS inches (mm)

A	B	Drain to Overflow	Drain Diameter / Clearance
2 (50)	8 3/4 (220)	14 3/4 (375)	2 (50) / 3 1/4 (80)

ELECTRICAL DATA

Component	Specification	Requirement
Pump	.75 HP; 5 AMP; 120 V	15 AMP; 120V, separate circuit; Class A GFCI
Optional Heater (whirlpool model)	1.5KW; 12 AMP; 120 V	15 AMP; 120V, separate circuit; Class A GFCI

NOTES:

1) Where applicable, utilize cut-out templates packed with unit for deck cutouts.

2) 16 x 16 (405 x 405) minimum access required at pump/blower location(s).