

**Plan Integral**

**44985011701 Washbasin module 2 Double paper hand towel cabinet**

**PRODUCT**



**DRAWING**

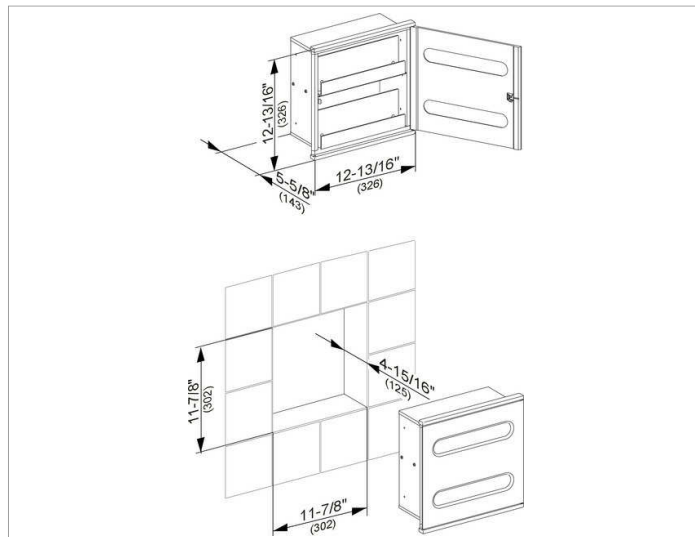

**PRODUCT ATTRIBUTES**

for recessed installation  
 front: aluminum lacquered  
 as desired aluminum silver (RAL 9006) or white (RAL 9010)  
 recessed body: sheet steel zinc-plated and lacquered  
 complete, consisting of:  
 - 2 Paper towel dispensers, each for max. 100 paper towels (9-13/16 x 9-1/1 inches)  
 - Security release key

**SURFACE**

polished chrome/aluminum lacquered/left

**DIMENSION**

12,83 x 12,8 x 5,63 "

**SPECIFICATIONS**

KEUCO PLAN INTEGRAL Washbasin Module 2, 44985011701  
 A classic washbasin module in a stylish yet functional design for recessed installation  
 front: chrome-plated/aluminum lacquered  
 as desired aluminium silver (RAL 9006) or white (RAL 9010)  
 recessed carcass: sheet steel zinc-plated and lacquered  
 door left hand hinged,  
 the recessed grip is covered, with a lock and an integrated releasing mechanism,

complete, consisting of:  
 2 Paper towel dispensers, each for max. 100 paper towels (9-7/8 x 9-1/16")

Exterior measurements: Height 12-13/16", width 12-13/16", depth 5-5/8"

Cutout measurements: Height 11-7/8", width 11-7/8", depth 4-15/16"

**Warranty:** KEUCO products are covered by a 5-year manufacturer's warranty, in effect from the date of purchase. During this time, proven product defects will be remedied free of charge. Warranty claims must be filed in writing, including a detailed description of the defect immediately after a defect has occurred. For a copy of our detailed product warranty policy, please contact us at [office-usa@keuco.com](mailto:office-usa@keuco.com).

**Installation:** KEUCO products must be installed by a qualified professional in accordance with the respective installation guidelines and any applicable federal / local building codes and regulations.