

# ARIEL

## STEAM CABIN INSTALLATION INSTRUCTIONS



MODEL: ZAA212

### Door handles:

Unscrew the door knob from the door handle; remove one vinyl washer, but leave the plastic tube and the last vinyl washer; place threaded section with plastic tube through one door handle hole of a door; reinstall the vinyl washer and then reinstall door knob onto the door handle and glass door.

If the threads are too short to re-screw these items together, over the glass, remove the fully-threaded rod from either the door handle or doorknob (whichever side it stuck to) and then reinstall it into the door knob with 2 to 3 full turns.

Inside the bag of door handle hardware, there should also be (2) more vinyl washers, (2) hard-plastic washers, and (2) decorative-caps.

Use (1) vinyl washer, place it in between the unscrewed-end of the door handle and glass door; take (1) screw, place it through the rounded side of the hard-plastic washer and then screw into the door handle, through the glass door. Place decorative-cap over the hard-plastic washer to cover the screw. Repeat to the remaining door.

### Handheld shower wand and hose:

Install the hexagonal end of the hose with a rubber gasket onto the wall panel water junction on the left wall panel. Install the opposite end of the hose, the tapered and rounded end, with a rubber gasket onto the handheld shower wand.

### Adjustable shower wand holder:

Remove screw-cover caps from the end-mounts of the bar. Place sealant onto the screw and screw-holes. Screw lower mount into place; install bar, and then screw upper mount into place; replace the screw-cover caps.

### Mirror:

Place a cap-anchor then a soft washer onto a screw, and then put sealant onto the screw and screw-holes and screw mirror onto the rear panel. Place decorative-cap onto cap-anchor, covering the screw.

# INTRODUCTION

Thank you for choosing AMERISTEAM bathroom products! Please read these instructions to help safely and properly assembly, use, and maintenance this product. Keep these instructions for future use.

This multi-functional shower and steam cabin is easy to assemble and use; featuring a centralized computer system that will control the aromatherapy-steam, hydro-massage shower-jets, overhead lighting, exhaust fan, FM radio, and auxiliary-CD input. It is the first choice for multifunctional steam shower systems for both household and commercial usage. The high-speed and highly efficient steam generator can save time and energy. It can start producing steam within a few short seconds of starting.

Steam systems can expose your skin to controlled high temperatures that will open skin pores, expand capillaries, improve blood and lymph circulation, virtually eliminate fatigue, relax and refresh your body. It can also thoroughly help flush dirt, grease, and bacteria from your skin to help absorb oxygen and moisture for soft, elastic, and healthy skin.

Aromatherapy can help relax your body and mind. It can help smooth muscle sores and help you sleep more easily. It can also help you recover from minor illnesses, help regulate your respiratory system, and help delay the aging physiology. Please consult your physician for more details of how steam aromatherapy can help you.

The computerized steam system is also equipped with a temperature and timer function that will allow you to set your preferred temperature and duration of usage of the steam system.

## INSTALLATION AND USAGE TIPS

- Major assembly required. While receiving this product, check condition and inventory of all accessories, hardware, and parts. Report any damage(s) to the carrier (if applicable) and dealer immediately. Contact your dealer if you have any questions.
- Please double check that you are using the correct screws of the marked screw packs, during the install process. If a mistake is made, it may result in damage to some parts.
- The waste pipe should be placed about 6-inches from the drain assembly of the enclosure, if using the flex-hose. Although, the flex-hose can be stretched a long distance, in times of servicing the unit, the drain assembly and waste pipe should be kept within a reasonable distance to maximize flow efficiency. Also, the flex-hose should always be kept on an even or downward slope – never an upward slope.
- When moving the assembled enclosure, make sure there is no extra weight on it and push/pull from the lowest possible position, preferably the base. Watch out for possible collisions, or strong vibrations.
- Do not permanently block in the enclosure, for ease of serviceability.
- This steam cabin is designed for indoor use only.
- To prevent any unwanted movement of the steam cabin, the enclosure should be installed on a flat, level, and non-slippery surface.
- A sealing agent must be used on all seams of adjoining pieces. A caulking gun is highly recommended for this task. While wiping away any excess sealant, be sure to press in the sealant into the seams they will be sealing. If done properly, this will help create a positive seal that will ensure a leak-free installation. Wipe away any excess sealant.
- If any surface has extra silicone residue, a soft cloth and soap/water mixture, or mineral spirits can be used to clean it.
- If the cabinet surface becomes dirty, use a wet towel to clean it.
- Daily cleaning of the enclosure is recommended to prevent heavy build ups of deposits.
- Do not use detergents that contain chemical solutions, granules, or tools with a rough surface to clean the steam cabinet.

## INSTALLING OF OTHER HARDWARE

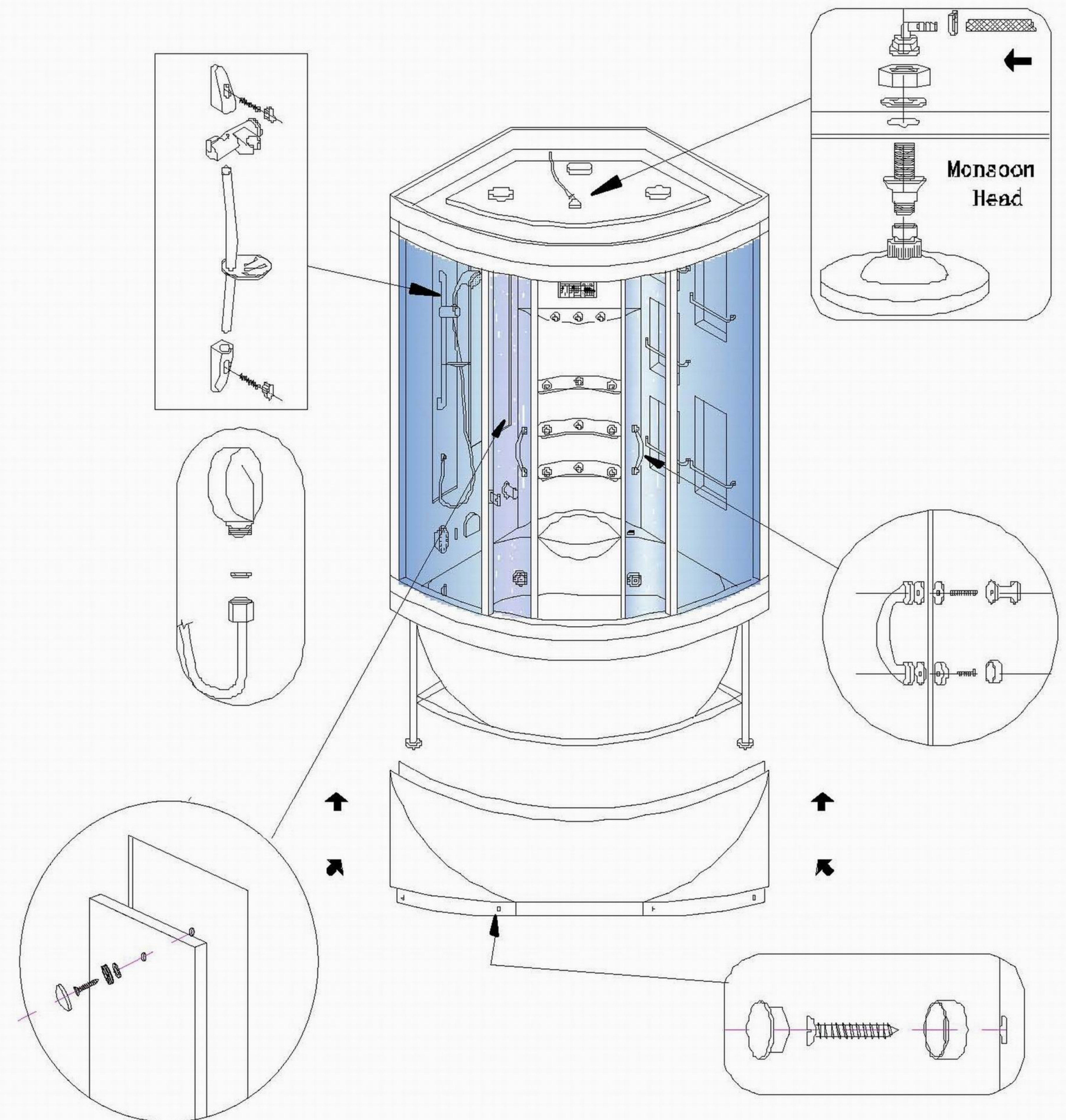

# INSTALLATION OF SLIDING GLASS DOORS AND GASKETS

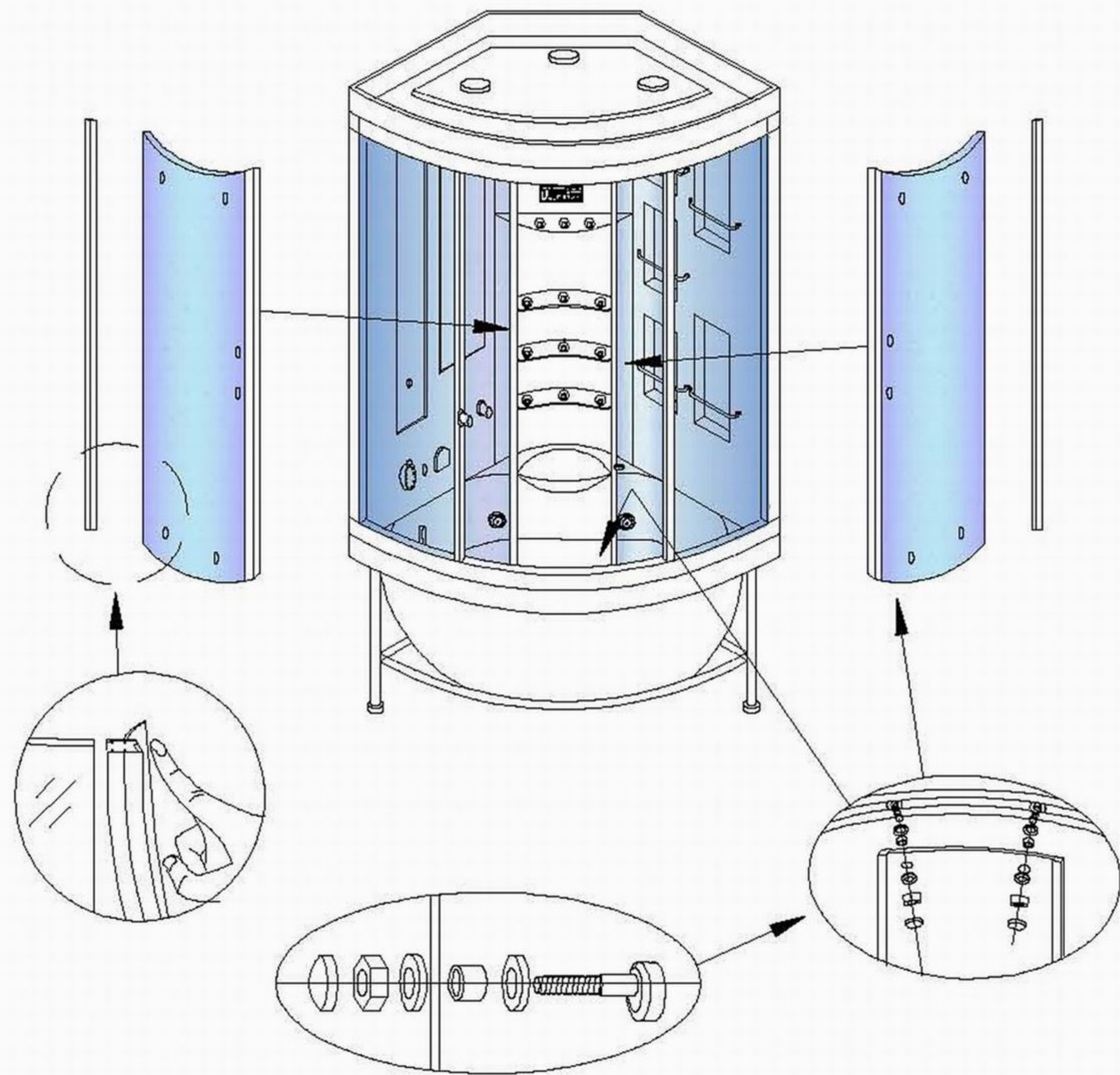

Before installing the doors, it is recommended to go over and seal all adjoining seams with sealant from the inside to ensure there are not any broken seals or unsealed corners from working with multiple pieces sealed at different stages during the assembly process. For example, seal the base to panels, panels to panels, panels to rails, base to rails, rails to glass, etc...

Partially disassemble the door rollers from door rail. Note in which order the decorative metal nut, main metal nut, and plastic washer come off the door roller assembly. Leave the plastic tube and last plastic washer on the door roller. Starting with two center holes for the door handle toward the center of the enclosure, partially install the door onto two top door rails. Ensure that the "plastic tubes" are within the glass holes. Reinstall the plastic washers and lightly screw in the main metal nuts. Repeat this step to lower door rollers and then last door.

After both doors are loosely installed, from the inside of the enclosure, close both doors and adjust the door-rollers, so that the doors align evenly. Tighten all the main metal nuts and then reinstall the decorative metal nuts.

Place on the vinyl door seals ("F"-type gaskets) onto the outermost edges of the sliding glass doors with the flaps facing the stationary glass panels.

- Do not use harsh chemicals or rough abrasives; or liquids such as ketone (acetone) or chlorine.
- Never expose the steam cabin near an organic solution like formic acid or formaldehyde.
- If there is a scratch found on the acrylic surface, polish with #1500 to #2000 grit sandpaper, and then apply a polishing compound or toothpaste and rub with a soft cloth.
- Do not impact the enclosure with a hard object or scratch the surface with a knife.
- Adjust the water temperature control valve (mixer valve) slowly to avoid scalding.
- Be cautious not to touch the steam nozzle when it is in use or just after it has been used, as it is very hot and may scald.
- Keep the steam cabinet ventilated, if not being used for long periods of time.
- If the door does not slide smoothly, adjustments of the door rollers may need to be made; or lubricants can be placed on the wheels. Waterproof grease is recommended.
- Waterproof grease can also be used on any gaskets or movable seals to reduce squeaking, protect, prolong, and improve overall function.
- Power requirement: 110 ~ 120 VAC / 60 HZ / 30 AMP / +10 AWG
- The electrical and metal components of the steam cabin should be well electrically grounded.
- Do not try to disassemble the control box, or modify the steam cabin without contacting your dealer for professional help.
- When showering, do not use outside electrical appliances inside the shower enclosure for risk of electrical shock.
- Children should not use this steam cabinet without adult supervision.
- **25.4 millimeters is equal to 1 inch; or, the value of "mm" divided by "25.4" is equal to "inches". Example: 1016 mm / "25.4" = 40 inches; or, 0.5 inch x 25.4 = 12.7 mm.**
- Screw/Bolt dimension: "**M**" stands for metric; the first value is the **thread diameter**, and the second is the **overall length**; "**M**" "**Thread diameter**" x "**Overall length**"

Example: **M5 x 25** screw = **Metric 11/64" x 1"** screw; or, **M6 x 50** bolt = **Metric 1/4" x 2"** bolt.

## FEATURES

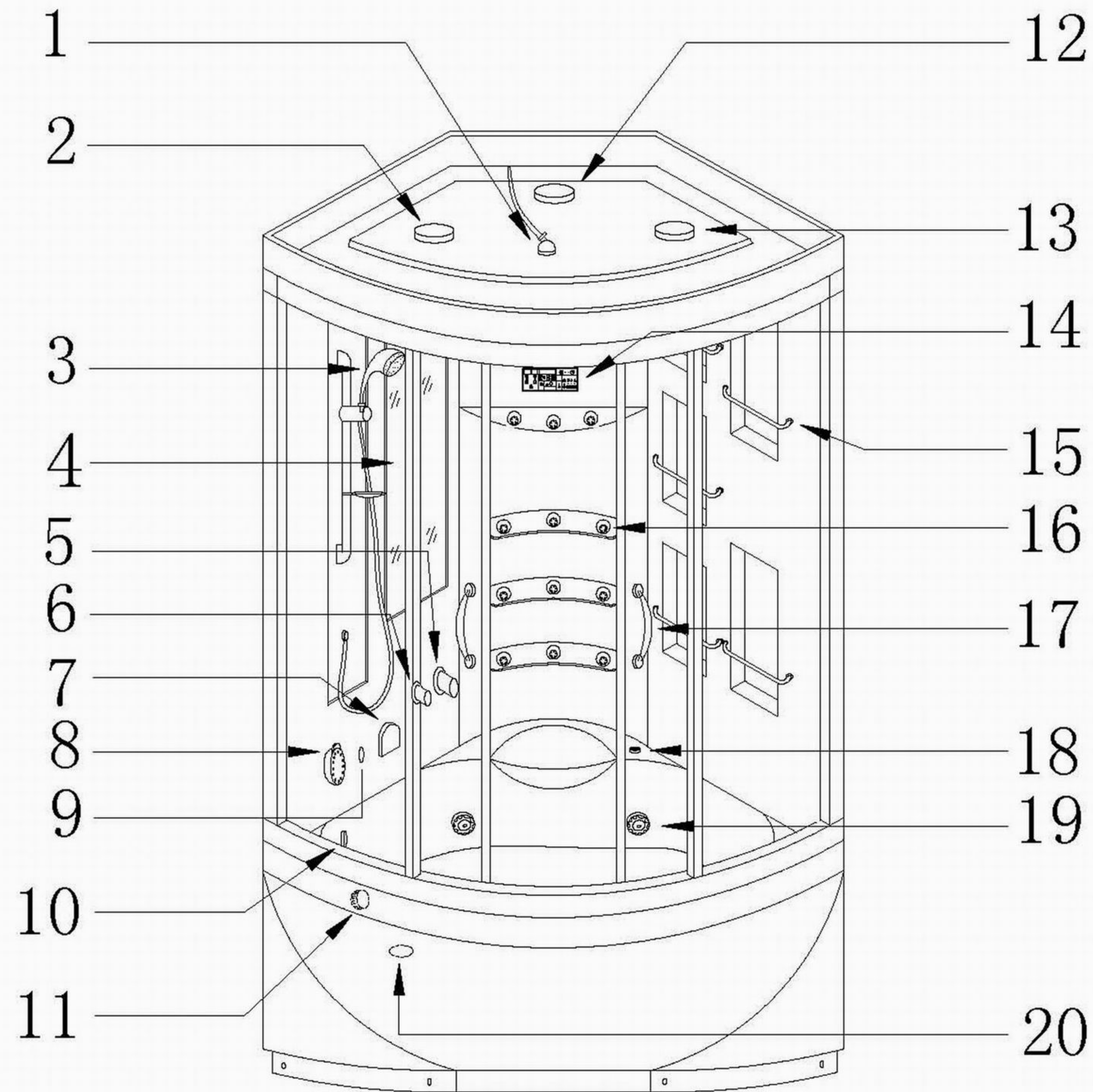

- 1) Monsoon Head
- 2) Loudspeaker
- 3) Shower Head
- 4) Glass
- 5) Diverter
- 6) Thermostatic faucet
- 7) Taps
- 8) Steam outlet
- 9) Steamer drain
- 10) Overflow

- 11) Backwater
- 12) Light
- 13) Exhaust Fan
- 14) Control Panel
- 15) Towel Rail
- 16) Jets
- 17) Handles
- 18) Air control knob
- 19) Whirlpool Jets
- 20) Drain

## INSTALLATION OF CEILING PANEL

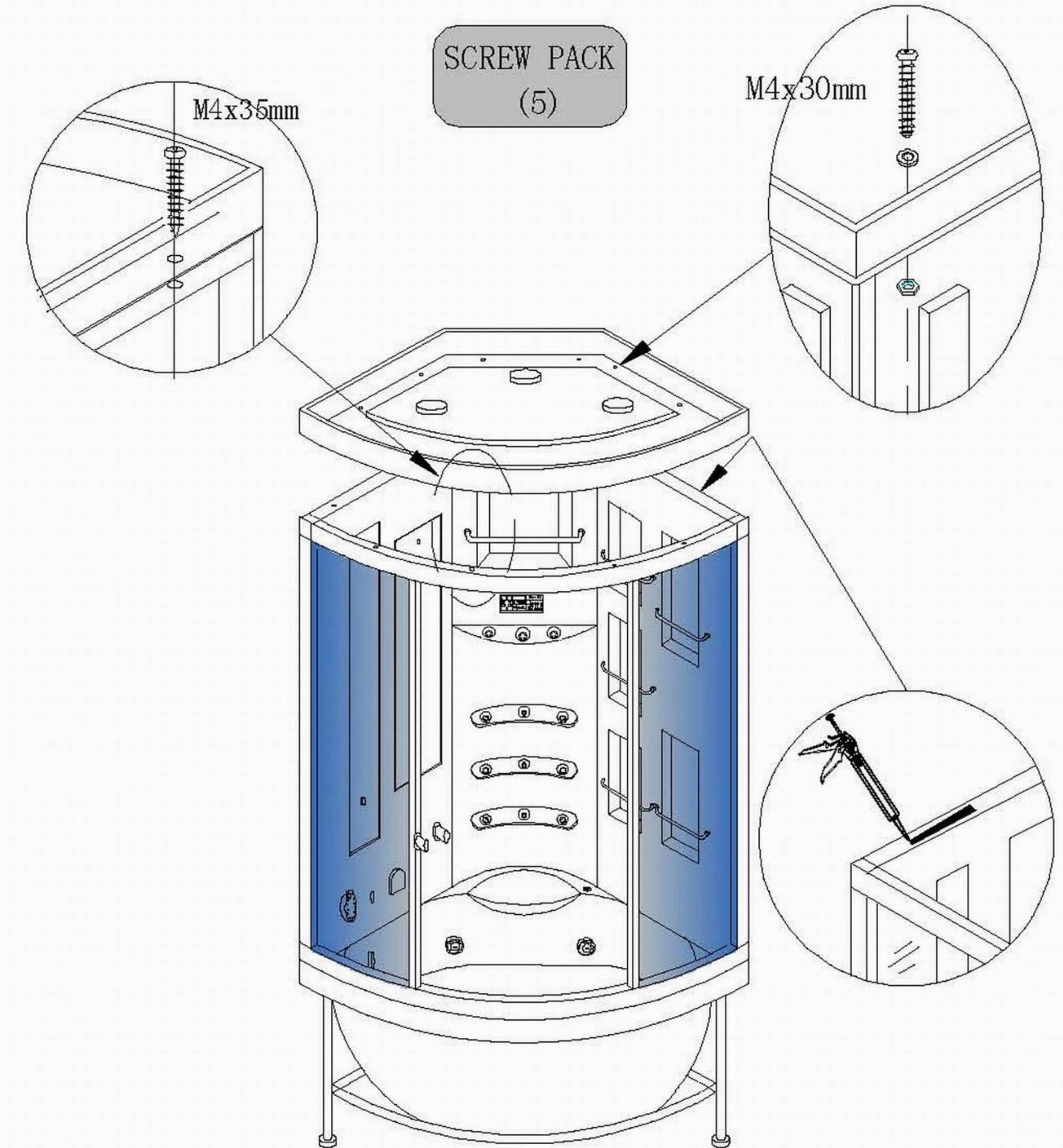

First dry-fit test the ceiling panel onto the shower enclosure to understand how the panels assemble together. Note screw-hole locations and sealing edges. Panels may be adjusted or screw-holes enlarged or re-drilled, so that the panels can fasten tightly together.

After sealing along the screw-holes and adjoining edges, use the M4x35mm (1/8" x 1-5/16") self-tapping screws and corresponding washers of "SCREW PACK (5)" to screw down the front of the ceiling to the top door rail of the enclosure.

Then using the M4 x 30mm (1/8" x 1-1/8") bolts and corresponding washers and nuts, bolt the ceiling to the rear panels. Fine adjustments of the rear panels can be easily made with moderate pressure.

Press in and wipe away any excess sealant from around all adjoining seams.

# INSTALLATION OF FRONT GLASS PANEL ASSEMBLY

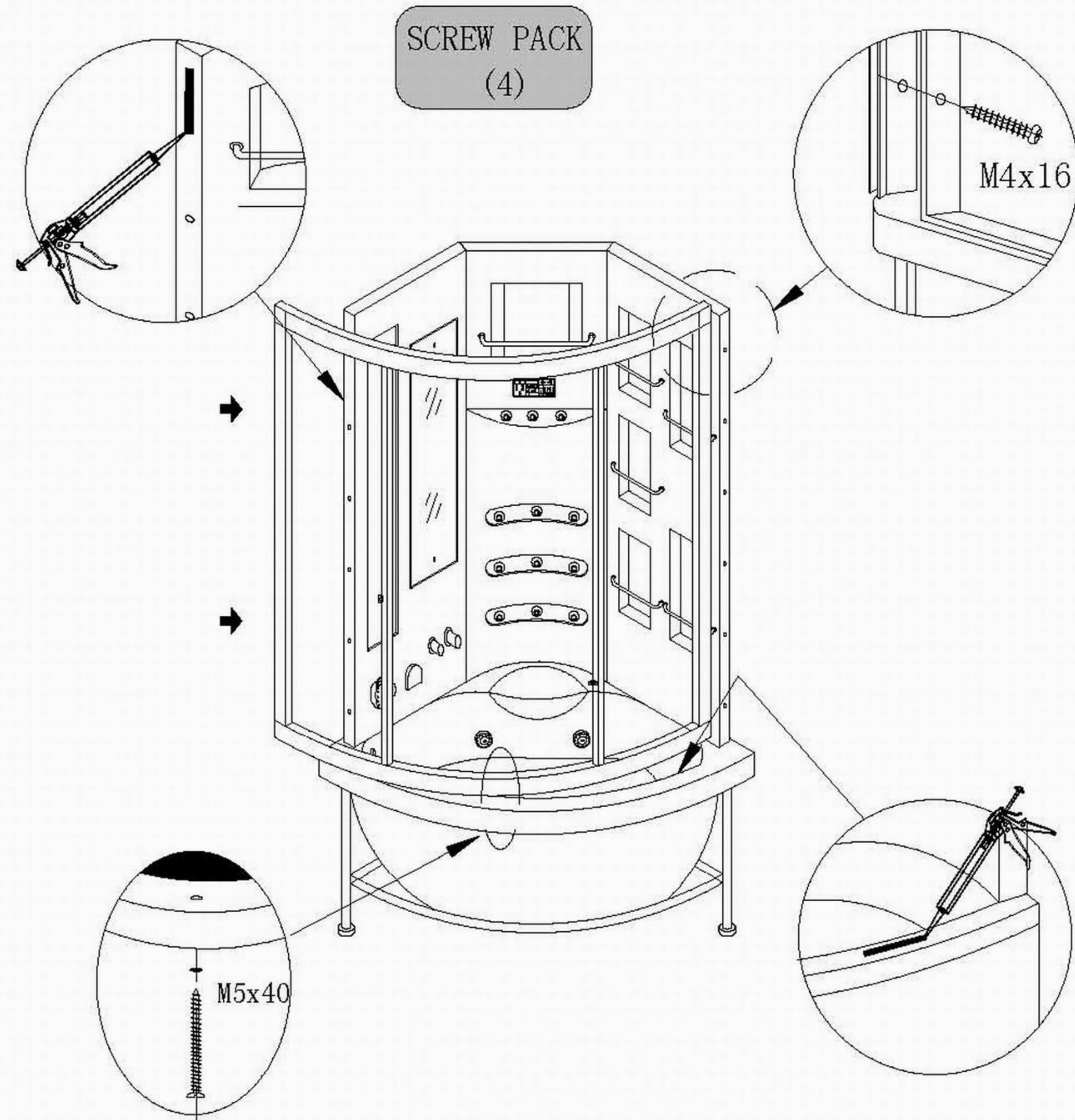

First dry-fit test front glass assembly onto the base and rear panel assembly to understand how the panels assemble. Note sealing edges and all screw-hole locations at adjoining corners and at the bottom rail and base. If holes do not line up immediately, adjust the panels so that they do. Holes may be enlarged or re-drilled so that the panels can fasten tightly together. The most important edges to be aligned are the bottom and sides.

After dry-fit test has been concluded, apply a generous amount of sealant along all adjoining edges and screw-holes. Screw the panels together using "SCREW PACK (4)".

Note M4x16mm (1/8" x 9/16") self-tapping screws and corresponding washers are for the side panels, and M5x60mm (11/64" x 1-3/8") self-tapping countersunk screw and plastic decorative screw cover/cap are for the center bottom rail.





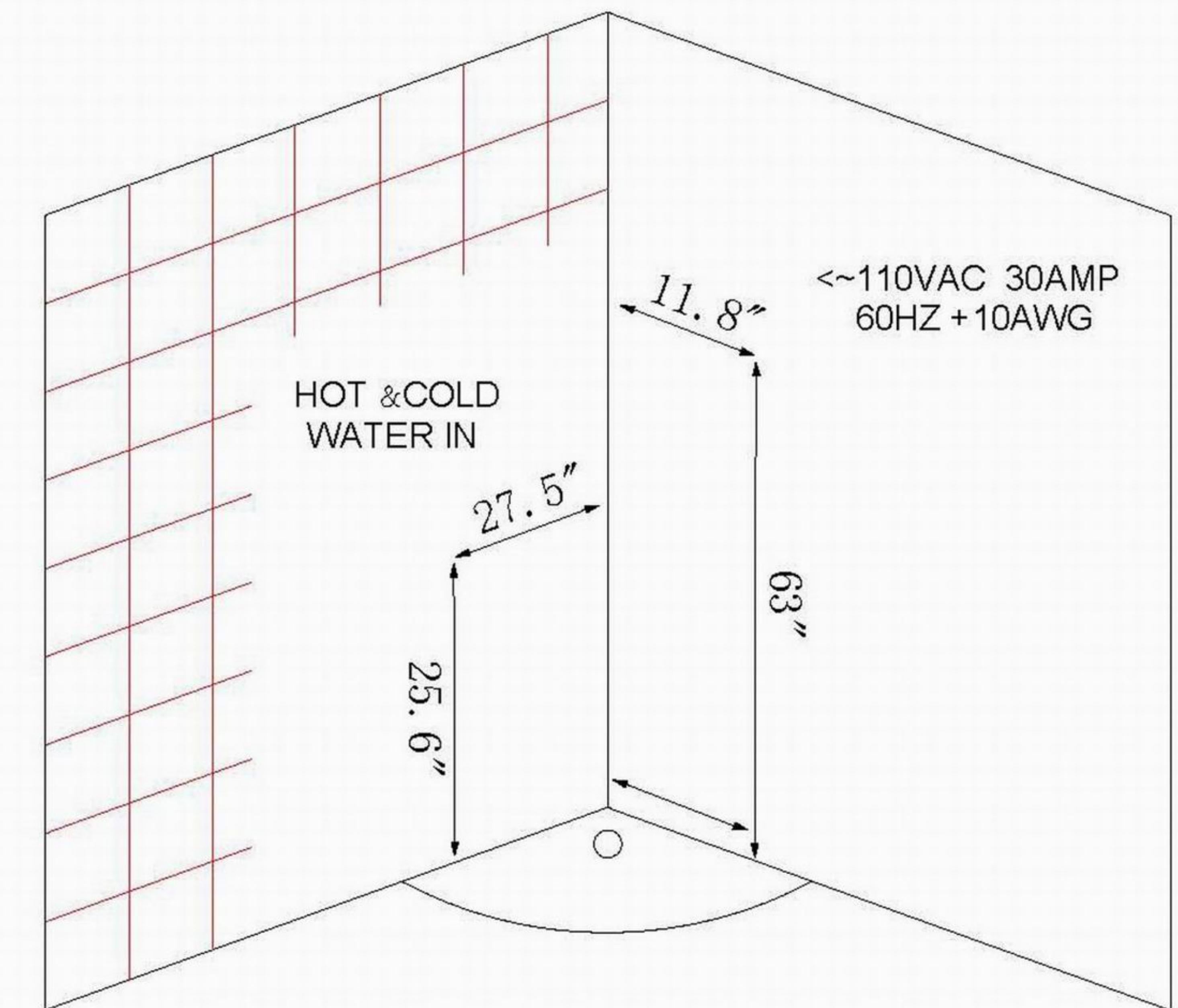
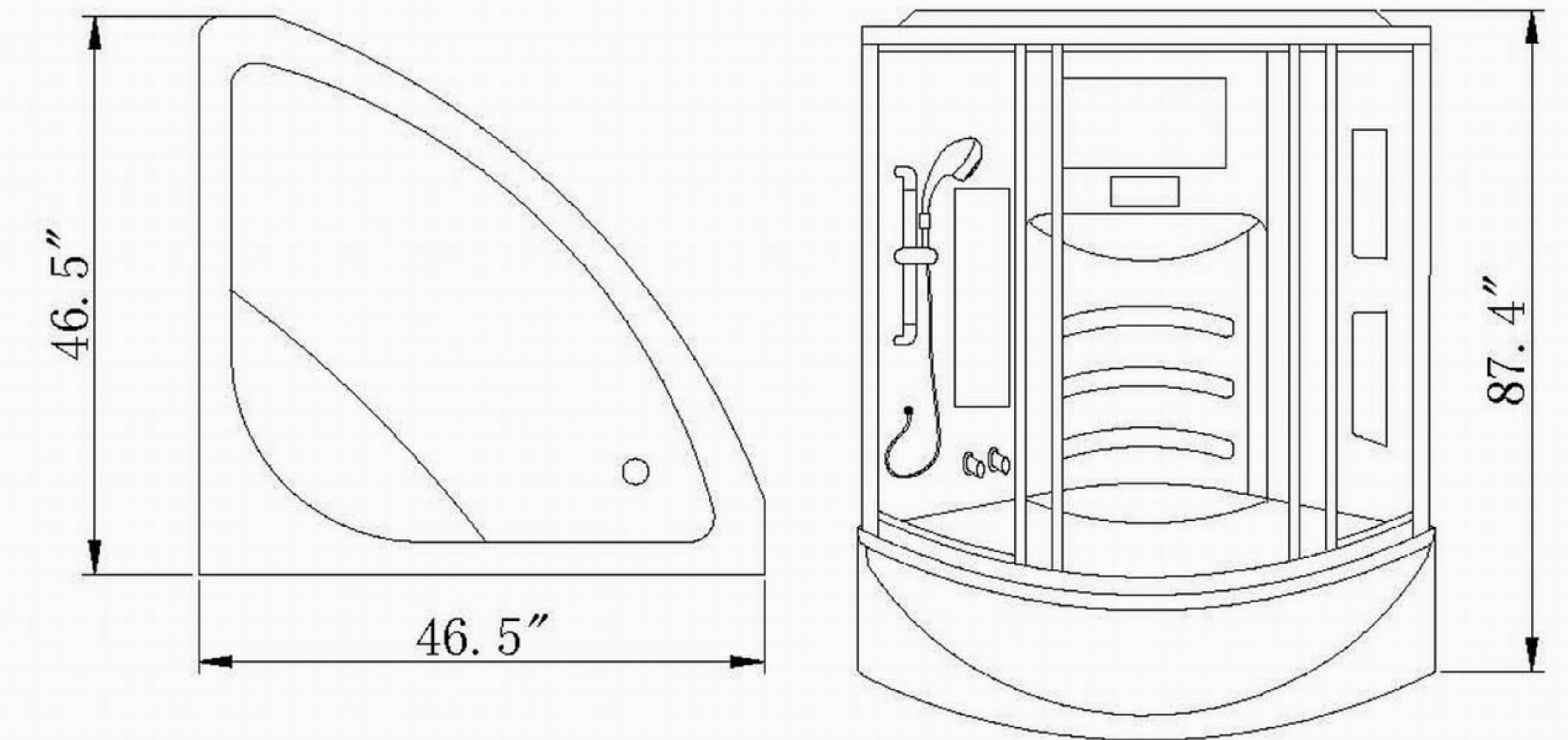

Press in and wipe away any excess sealant from around all adjoining seams.

# SPECIFICATIONS

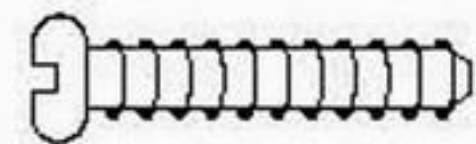

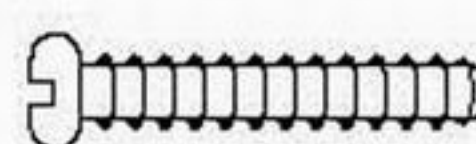
- 1) SIZE: 1180 x 1180 x 2220 mm (46.5" x 46.5" x 87.4")
- 2) WATER SUPPLY SIZE: 1/2-inch Male NPT
- 3) DRAIN PIPE SIZE: 1 1/2-inch
- 4) POWER RATING: ~3 KW
- 5) VOLTAGE RATING: 110~120 V
- 6) FREQUENCY: 60 HZ

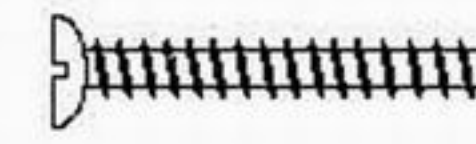
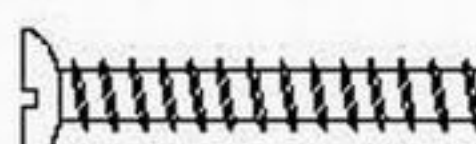
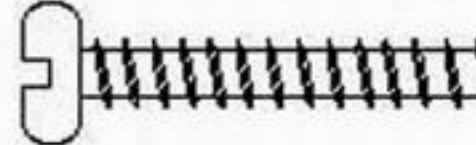
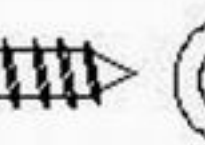
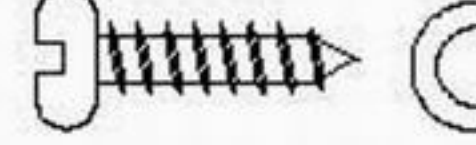
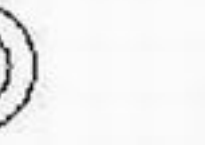
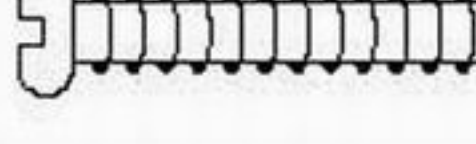
## SUPPLIED HARDWARE

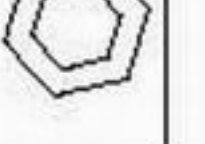
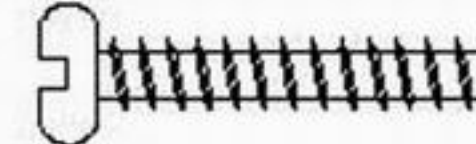
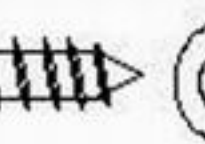
SCREW PACK (1)	M5x30	  	12
SCREW PACK (2)	M5x35	  	9
SCREW PACK (3)	M4x50		8
	M4x60		4
SCREW PACK (4)	M5x40	 	3
	M4x16	 	12
SCREW PACK (5)	M4x30	  	9
	M4x35	 	3

## DRAIN ASSEMBLY PICTURE (OPTIONAL)

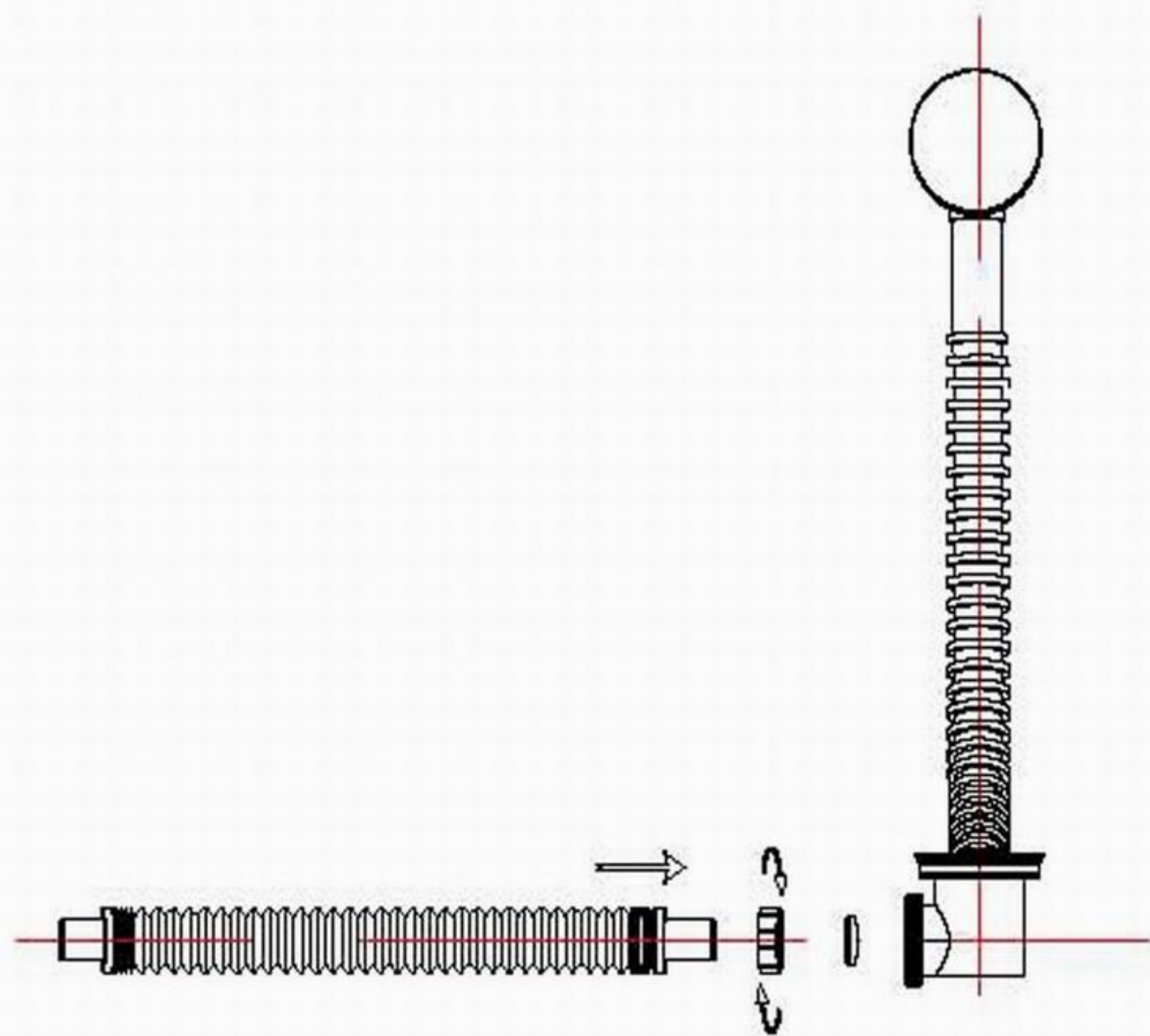

## BASIC TOOLS REQUIRED (not supplied)

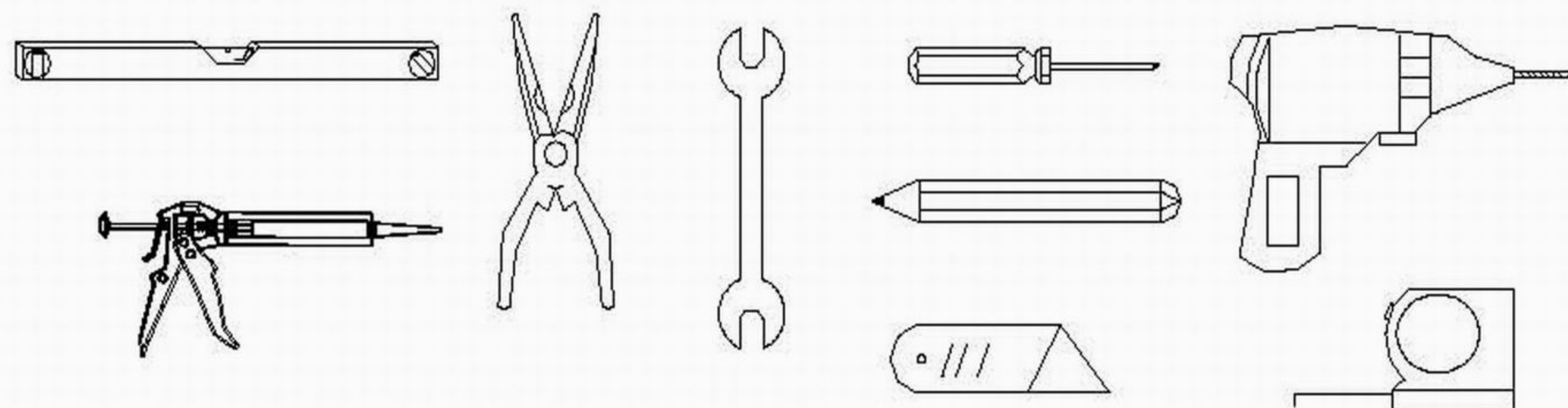

## ASSEMBLY OF FRONT GLASS PANEL

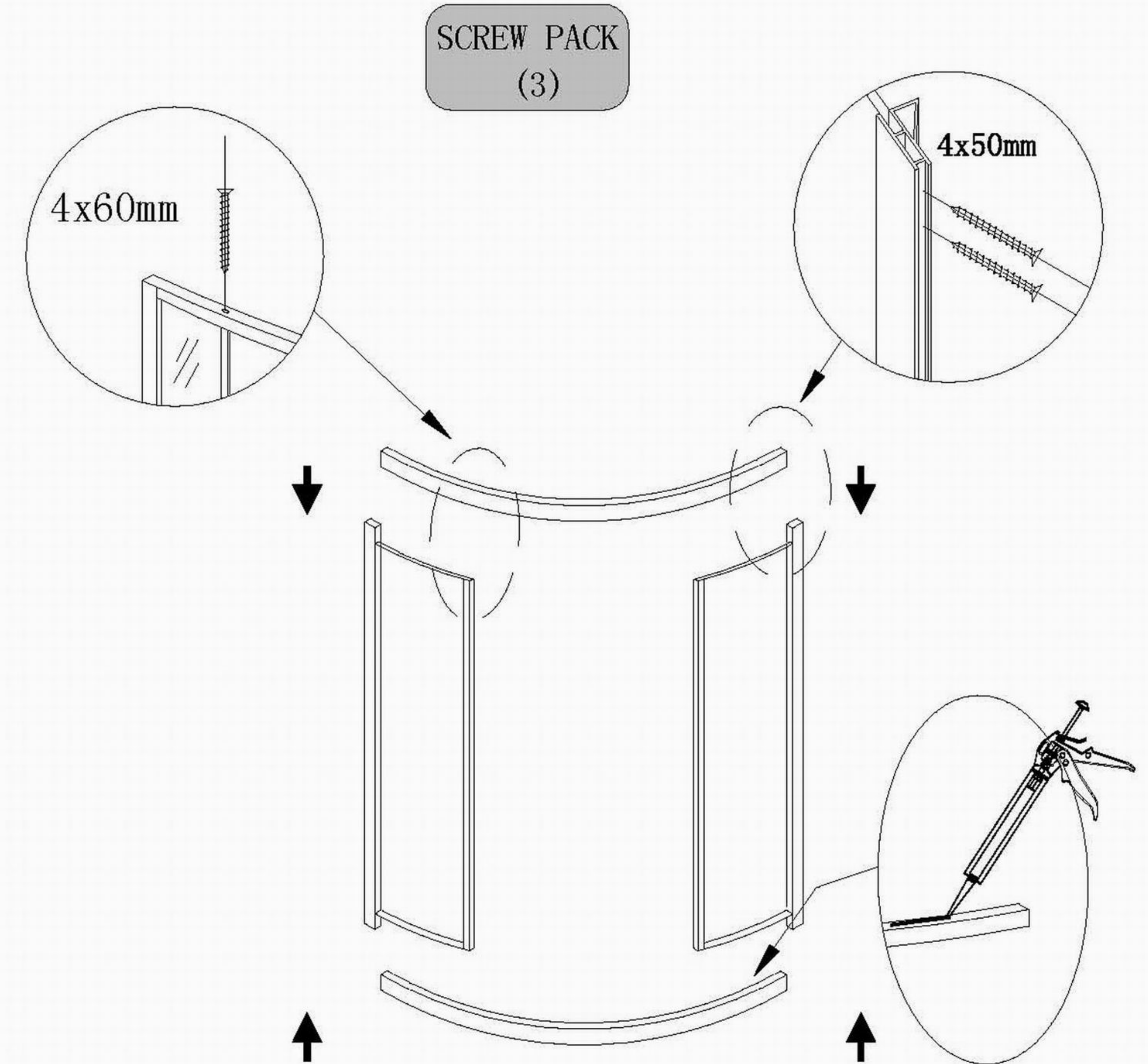

First dry-fit test all the panels and rails together to understand how the pieces assemble. Assemble both glass panels, first, onto one rail, and then assemble the last rail onto the open end of the glass panels, using "SCREW PACK (3)".

Note that each corner of each glass panel will require (1) M4x60mm (1/8" x 1-3/8") self-tapping screw from the top and bottom of each rail, or (2) M4x50mm (1/8" x 2") self-tapping screws from the side of each rail. Note the rail with one screw-hole in the center of the visible portion of the rail is the bottom rail.

After dry-fit test, apply a generous amount of sealant into the groves, screw-holes, and along the sides of adjoining edges.

Press in and wipe away any excess sealant from around all adjoining seams.

# INSTALLATION OF REAR PANEL ASSEMBLY

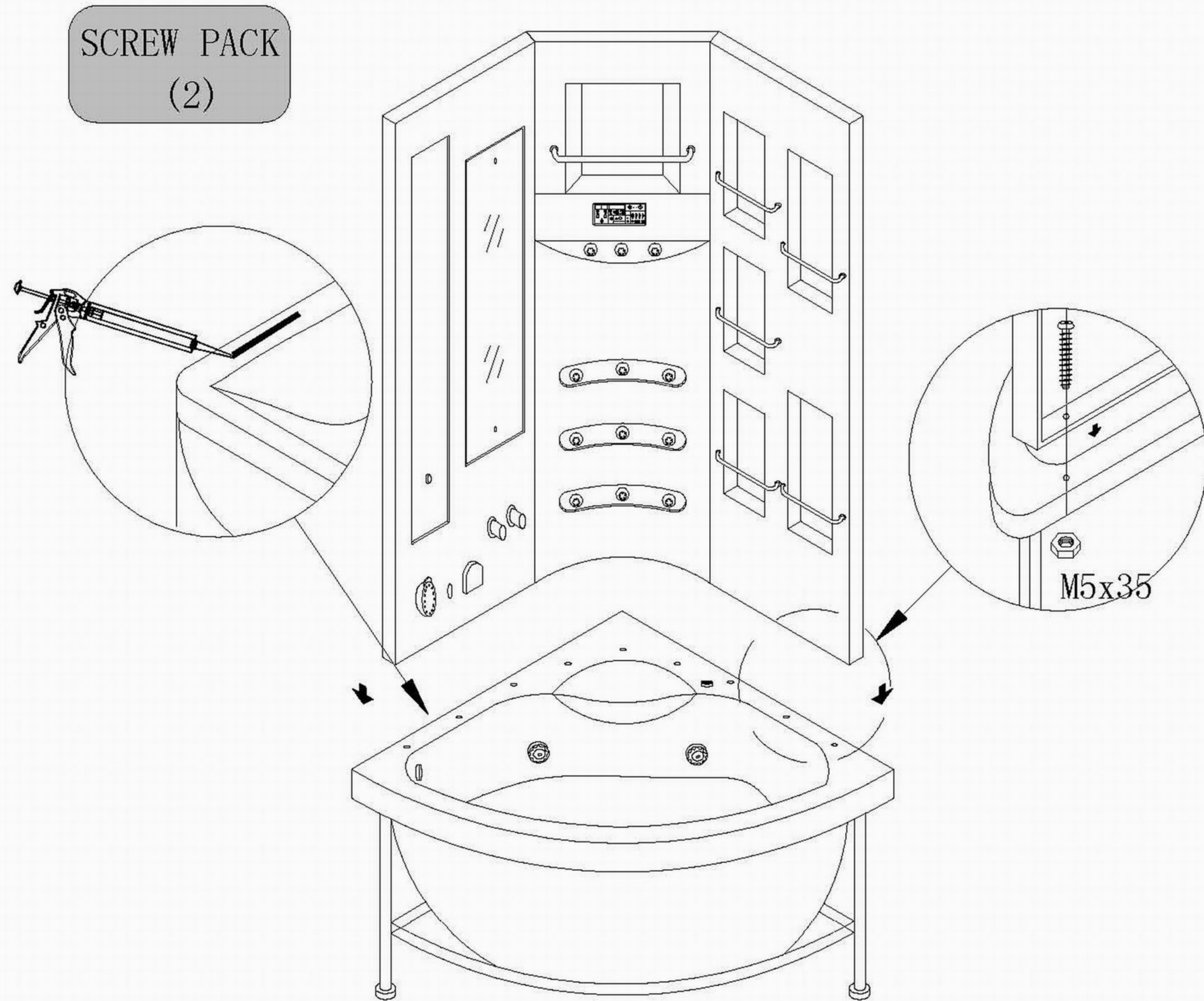

First dry-fit test the rear panel assembly onto the base. Check panel and screw-hole alignment.

If modifying screw-hole(s) at this location, do not modify the hole that the screw is threading into (tub), but only modify the screw-hole that the screw-thread is passing through (panel). Moving screw-holes or adding additional screws (not supplied) are okay. Remember to pilot drill new screw holes before threading screws into place.

Using similar techniques as the assembly of the rear panels, install, seal, and bolt the rear panels onto the base using M5x35 (11/64" x 1-5/16") bolts and corresponding nuts and washers of "SCREW PACK (2)".

# SUPPLIED PARTS

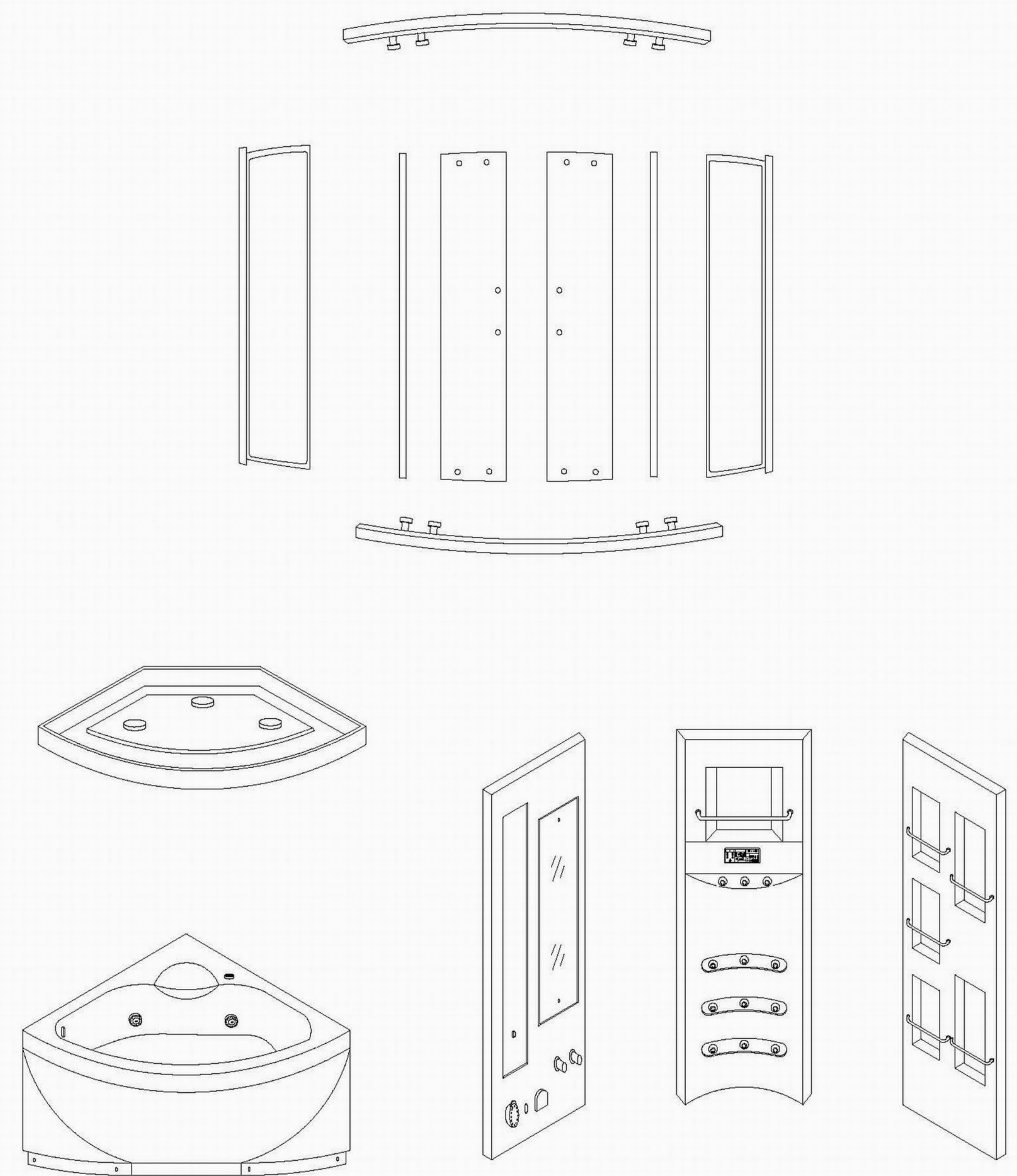



## INSTALLATION OF BASE

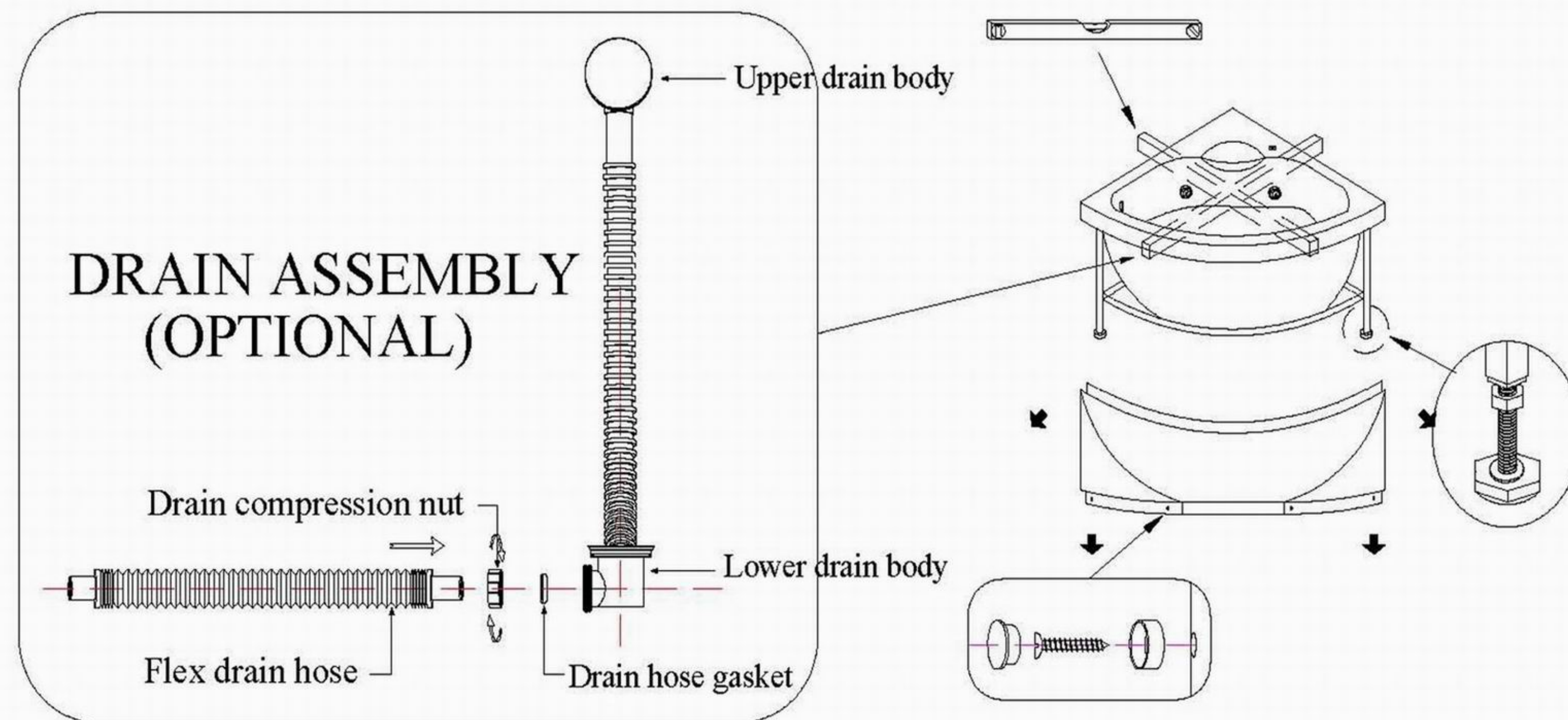

Temporarily placing the base into the exact location of usage, place a leveling tool along the top ledges of the base to ensure it is level. Remove the base and adjust the leveling legs underneath the base to level the top ledges, as needed. Generally, a slight bias toward the drain is better than a slight bias away from the drain. Tighten the nuts on the leveling legs to ensure they do not move. Make sure all the leveling legs are touching the ground as it may cause the enclosure to bind or rock, if they are not.

(OPTIONAL) Drain assembly: Attach the flexible drain hose and gasket onto the drain assembly. Sealant is recommended to be used at this connection. Place compression nut onto flex hose, then place flex hose gasket onto flex hose and then apply generous amount of sealant onto both sides of the gasket. Place the flex hose into lower drain body and tighten the compression nut sealing the flex hose to the drain assembly.

While wiping away any excess sealant, press the sealant into seams they will be sealing. If done properly, this will help create a positive seal that will ensure a leak-free installation.

## ASSEMBLY OF REAR AND SIDE PANELS

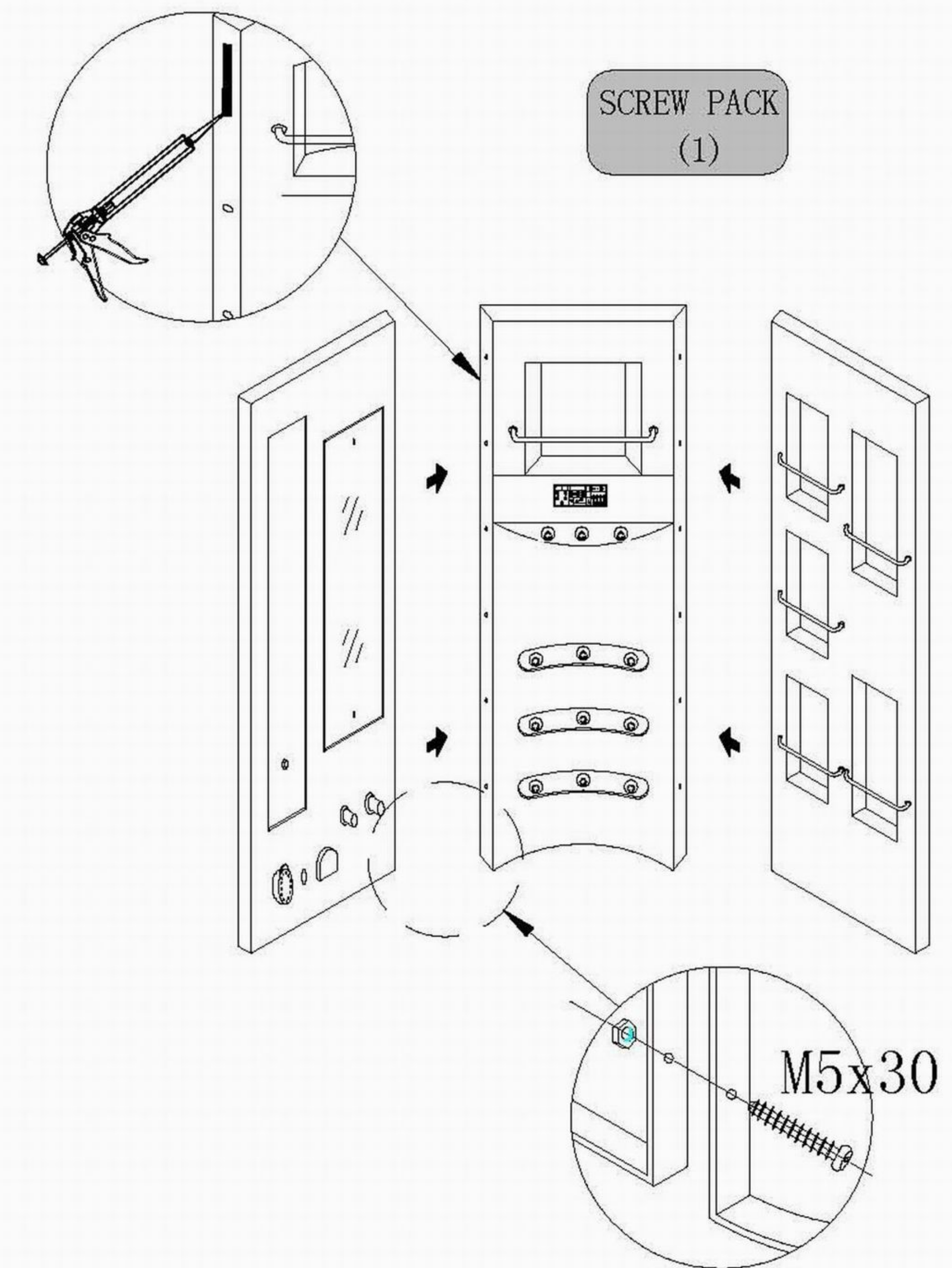

Working on a flat surface, align and loosely bolt the center panel and (1) side panel together using the M5x30mm (11/64" x 1") bolts and corresponding nuts and washers of "SCREW PACK (1)". Note which side you place the nut on so that you can easily reach it with a wrench.

Tighten the panels together just enough for the tip of calking gun can fit in between both panels. Caulk along one panel, passing over each bolt and screw-holes, and then tighten the panels together. Make sure the bottoms of panels are aligned along a flat surface. Press in and wipe away any excess sealant. Allowing sealant to cover the screws/bolts, threads, and nuts will help ensure they will not come loose. Repeat this step to the remaining panel on the appropriate side.

Please note that any screw-hole that is on an acrylic-fiberglass panel can be slightly enlarged, modified, or completely moved and re-drilled in a nearby location, so that the panels can fasten more tightly together. Seal any hole that is not used or use another type of screw/bolt to make use of it.