

Edition 300

30201171251 Mirror cabinet

PRODUCT



DRAWING

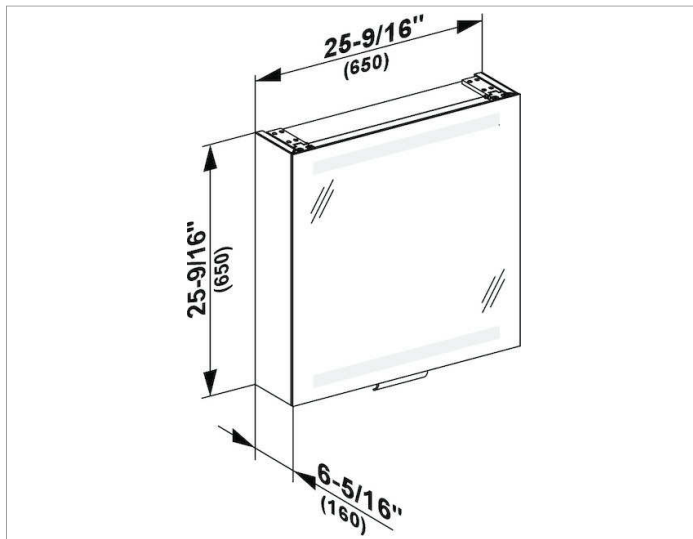

PRODUCT ATTRIBUTES

1 liftup double sided crystal glass mirrored door with sealed edges, mirrored sides
 flourescent light tube 2 x 14 watt T5

EQUIPMENT

- 1 light switch (external)
- 3 sockets (1 of them external)
- 1 sliding cosmetic mirror (7-7/8 x 20-1/2 inches)
- 5 adjustable glass shelves
 (3 shelves 14-3/4 x 3-9/16 inches
 and 2 shelves 10-13/16 x 3-9/16 inches)

SURFACE

silver anodized

SPECIFICATIONS

KEUCO Edition 300 Mirror cabinet 30201171251
 High quality Mirror cabinet in elegant design

1 liftup double sided crystal glass mirrored door with sealed edges, mirrored sides
 flourescent light tube 2 x 14 watt T5

- 1 light switch (external)
- 3 sockets (1 of them external)
- 1 sliding cosmetic mirror (7-7/8" x 20-1/2")
- 5 adjustable glass shelves
 (3 shelves 14-3/4" x 3-9/16"
 and 2 shelves 10-13/16" x 3-9/16")

25-9/16" x 25-9/16" x 6-5/16"

silver anodized

Warranty: KEUCO products are covered by a 5-year manufacturer's warranty, in effect from the date of purchase. During this time, proven product defects will be remedied free of charge. Warranty claims must be filed in writing, including a detailed description of the defect immediately after a defect has occurred. For a copy of our detailed product warranty policy, please contact us at office-usa@keuco.com.

Installation: KEUCO products must be installed by a qualified professional in accordance with the respective installation guidelines and any applicable federal / local building codes and regulations.