

Edition 300

30052019000 Lotion dispenser

PRODUCT



DRAWING

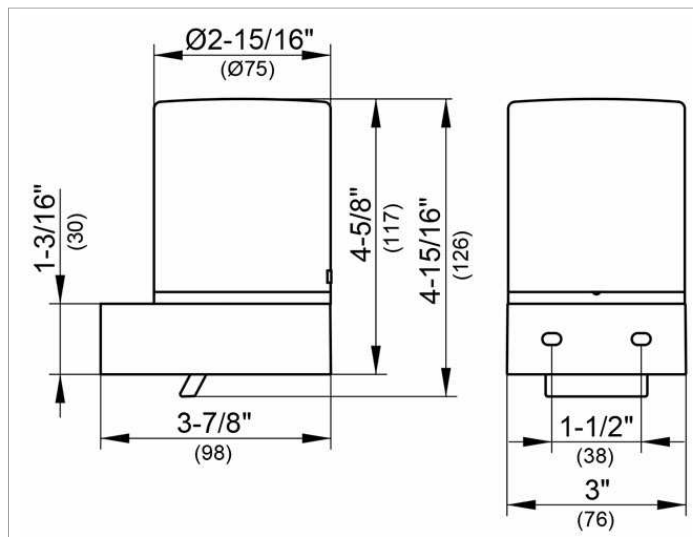

PRODUCT ATTRIBUTES

crystal glass matte,
complete with holder and pump
Capacity: approx. 6.09 oz
Dosage: approx. 0.02 oz/stroke

SURFACE

chrome-plated

SPECIFICATIONS

KEUCO EDITION 300 lotion dispenser 30052019000, for wall installation (6.09 oz)
chrome-plated lotion dispenser in aesthetic and classic design
wall mounted model complete with a removable crystall glass,
for easy cleaning and filling,
a high-class and long-lasting pump,
capacity: 6.09 oz, for standard liquid soap,
dosage: approx. 0.02 oz/stroke,
base diameter: 3", height 4-15/16",
projection: 3-7/8"
The lotion dispenser is fitted with 2 hidden fixing points
2 wall plugs, Fischer FU 1/4" x 1-3/4" and 2 wall screws are supplied

Warranty: KEUCO products are covered by a 5-year manufacturer's warranty, in effect from the date of purchase. During this time, proven product defects will be remedied free of charge. Warranty claims must be filed in writing, including a detailed description of the defect immediately after a defect has occurred. For a copy of our detailed product warranty policy, please contact us at office-usa@keuco.com.

Installation: KEUCO products must be installed by a qualified professional in accordance with the respective installation guidelines and any applicable federal / local building codes and regulations.