

Edition 300
30018010000 Towel holder

PRODUCT

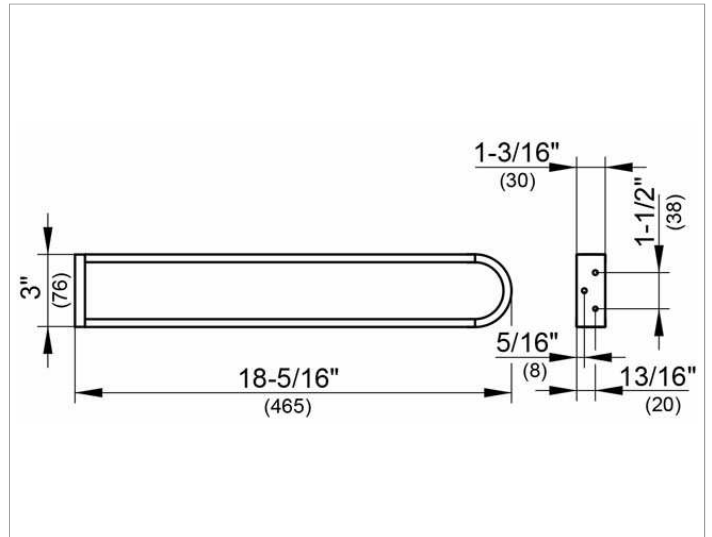

DRAWING



PRODUCT ATTRIBUTES

fixed

SURFACE

chrome-plated

DIMENSION

18,31 "

SPECIFICATIONS

KEUCO EDITION 300 towel holder 30018010000
chrome-plated towel holder in an aesthetic and classic design
two parallel arranged fixed arms
anti static, easy to clean,
projection: 18-5/16"
The towel holder is fitted with two hidden fixing points
2 wall plugs, Fischer FU 1/4" x 1-3/4" and 2 wall screws are supplied

Warranty: KEUCO products are covered by a 5-year manufacturer's warranty, in effect from the date of purchase. During this time, proven product defects will be remedied free of charge. Warranty claims must be filed in writing, including a detailed description of the defect immediately after a defect has occurred. For a copy of our detailed product warranty policy, please contact us at office-usa@keuco.com.

Installation: KEUCO products must be installed by a qualified professional in accordance with the respective installation guidelines and any applicable federal / local building codes and regulations.