

ASSEMBLY INSTRUCTION**1GHXL or C**

WALL MOUNT LAVATORY SET

**1GHXL****1GHXC****REMOVAL OF FAUCET:**

Always turn the water supply off before removing the existing faucet or disassembling a valve. Open both faucet handles to relieve water pressure and to ensure that the water has been successfully turned off.

CARE OF FAUCET:

The use of warm water and a soft cloth is all that is required to clean Rubinet products. The patina of our living finishes (Oil Rubbed Bronze & Tuscan Brass) will change as a result of normal use. Applying Mineral Oil on occasion will create a softer look, subtle color changes and character.

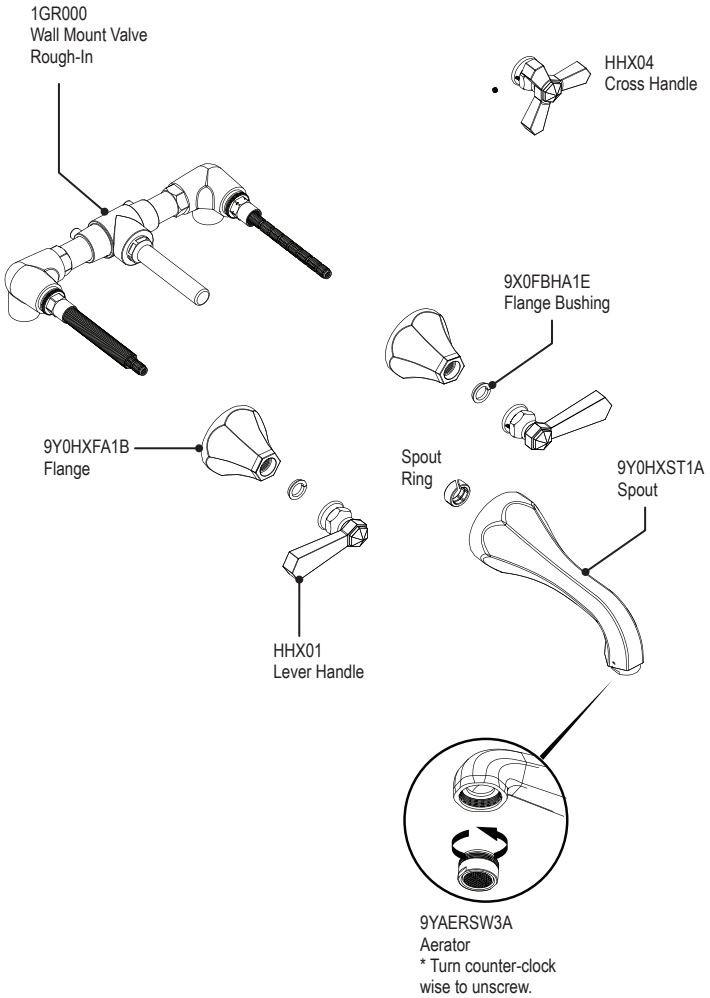

1

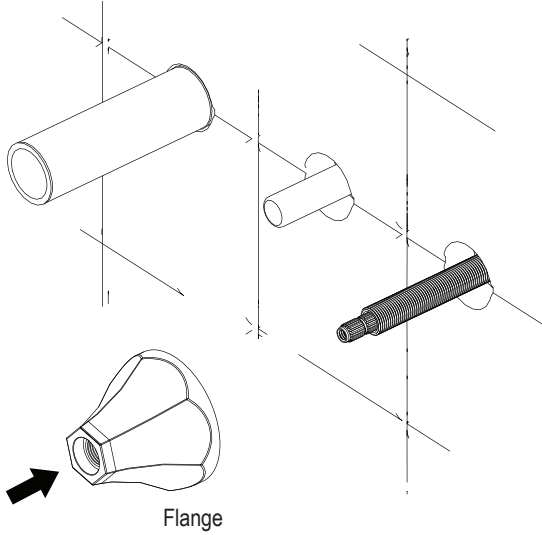

**MUST CUT FLUSH
TO THE FLANGE TRIM**
* 1 7/8" (47.5mm)
from the finished wall

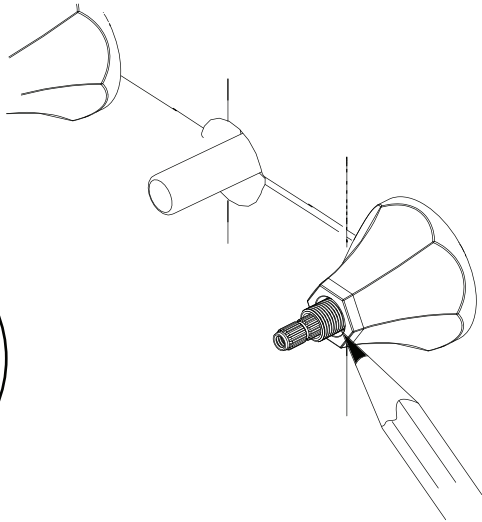
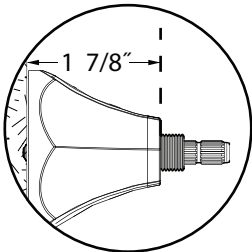

2

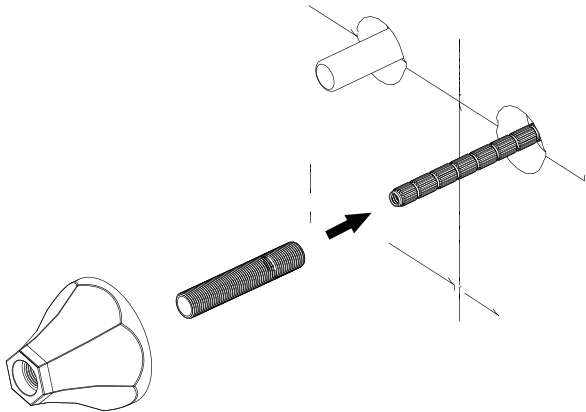
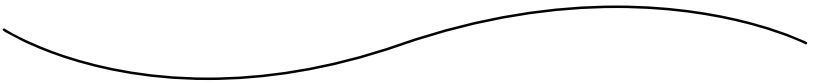
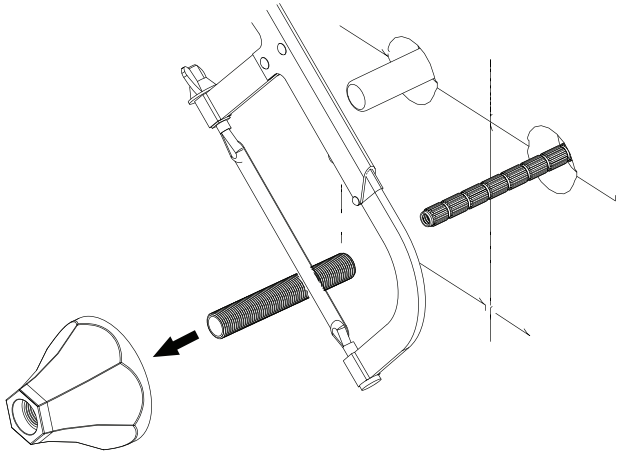

3

IF THE HANDLE DOES NOT FIT

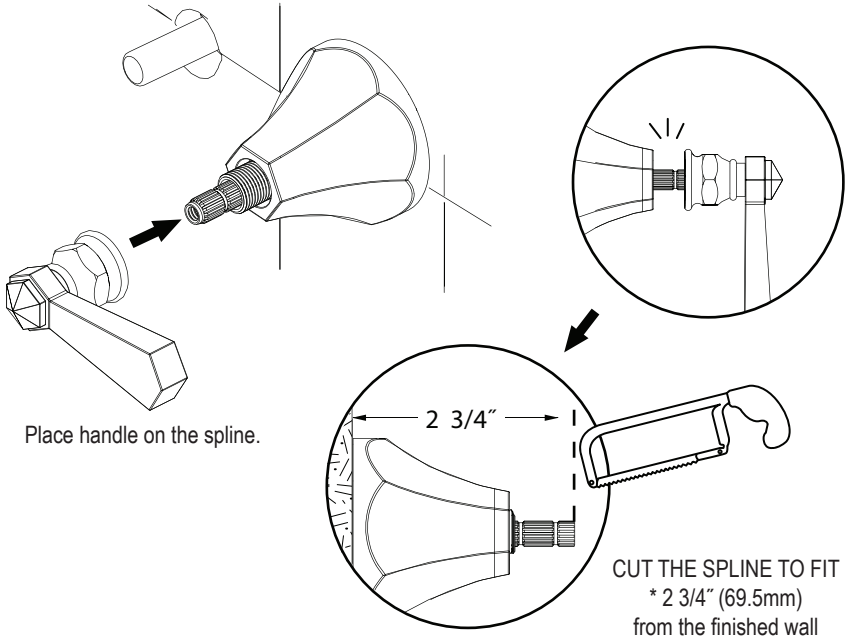

Turn each cartridge splines into **OFF** position before installing handles

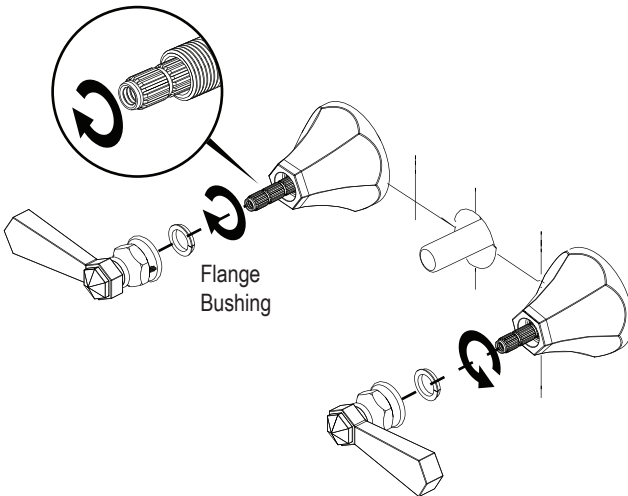

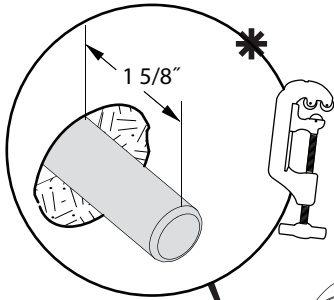

* Cut the Slip-Fit Shank 1 5/8" long from the finished wall and **MUST REMOVE ANY BURRS** before installing the Wall Spout.

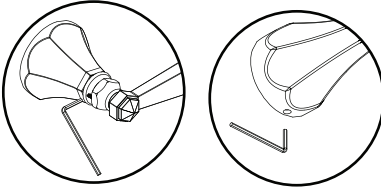
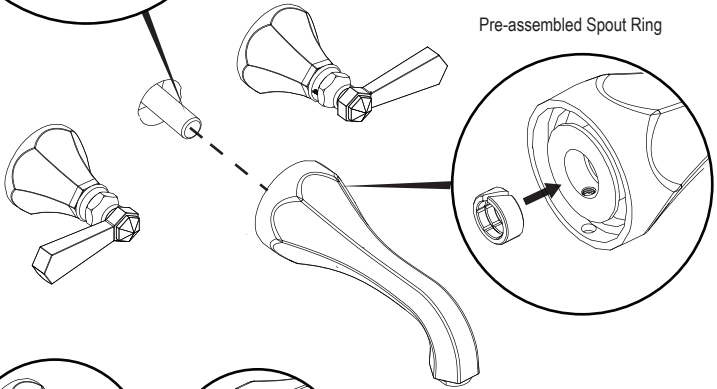

Tighten set screws to secure

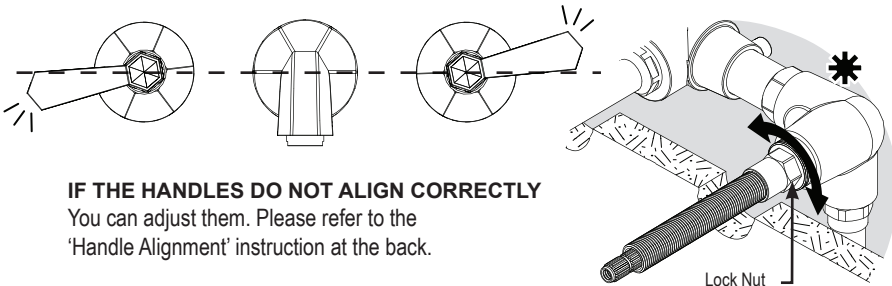

IF THE HANDLES DO NOT ALIGN CORRECTLY
You can adjust them. Please refer to the 'Handle Alignment' instruction at the back.

HANDLE ALIGNMENT (1G)

1



LOCK NUT
Loosen the lock nut using
* **17mm Deep Socket.**
1/2" Drive

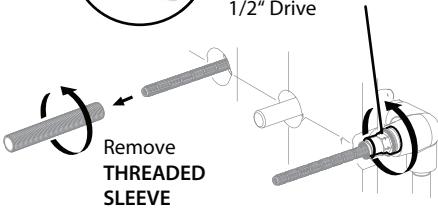

Remove
**THREADED
SLEEVE**

2

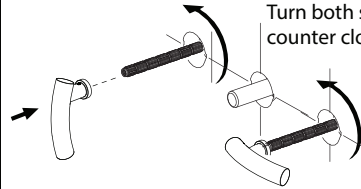

Use Handles to
unscrew cartridge.
Turn both splines
counter clock-wise.

3

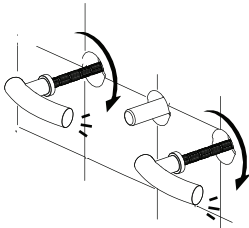

Once cartridge valves are loose, screw them
back into the faucet using the handle.
Stop when you feel a noticeable resistance.
Then remove handles.

4

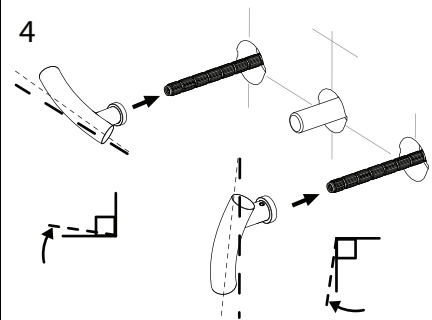

Replace Left Handle (hot) **one tooth off**
from the **OFF** position as shown.

And Right Handle (cold) **one tooth off**
from the **ON** position as shown.

5

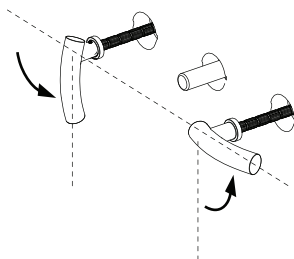

Turn the handles to the desired alignment.
(This will unscrew the cartridge)
This adjustment should not be more than 25°.

6

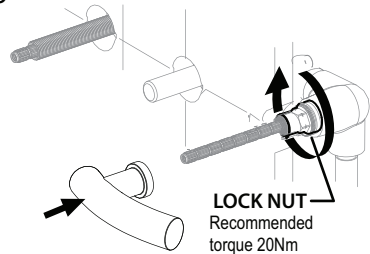

LOCK NUT
Recommended
torque 20Nm

Tighten Lock Nut using **17mm Deep Socket.**
wrench to secure cartridge valve position.

*Use handle to hold spline while tightening.

FEATURES:

- Brass construction with choice of 21 finishes
- Two Cross or Lever handles
- Quarter-turn ceramic disk cartridges
- 2.4 gpm @ 60 psi (Helps meet CalGreen regulation)

APPROVAL:

- AB1953 / NSF61
- ASME A 112.18.1
- CSA B125.1

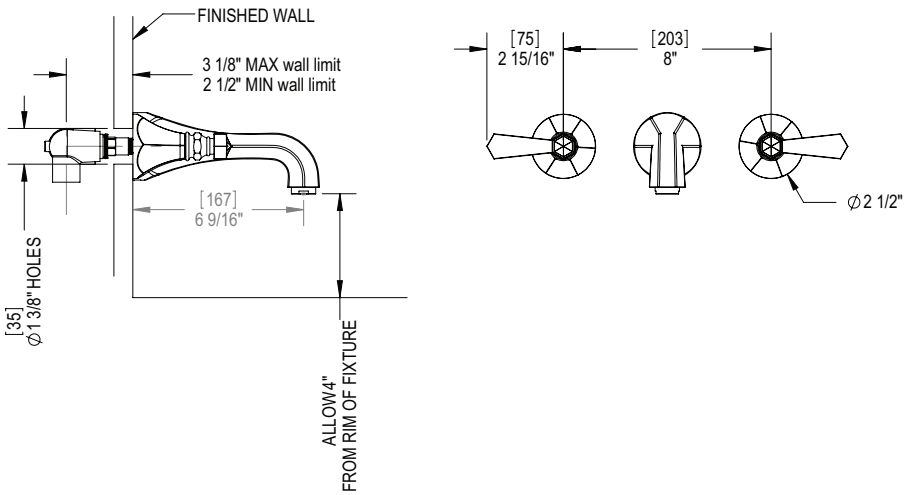

CONTACT US:

If you need assistance with installation, replacement parts or have any questions regarding your Rubinet product, please call a Customer Service representative at: 905-851-6781 toll free 1-800-461-5901 or visit www.rubinet.com