

**INSTALLATION MANUAL - GUIDE D'INSTALLATION**

**K301**

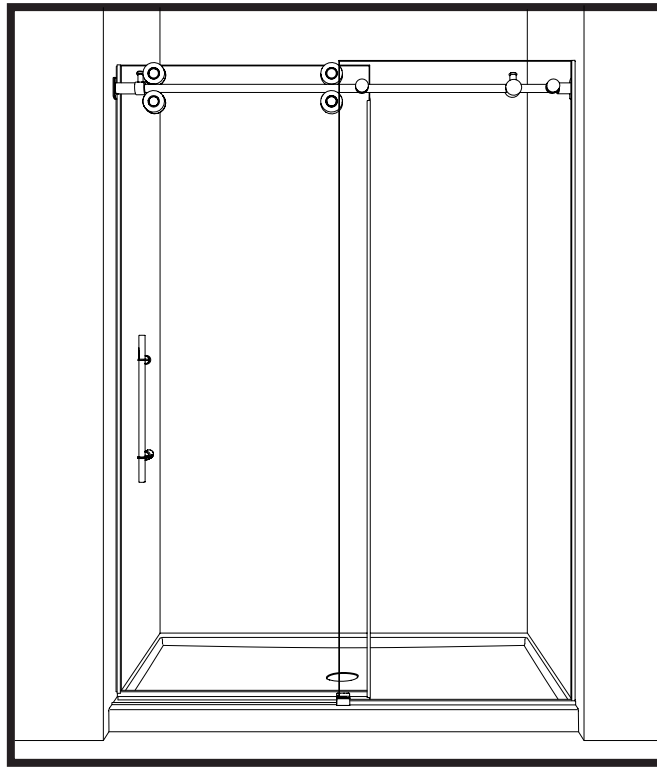

*SHOWER / DOUCHE*

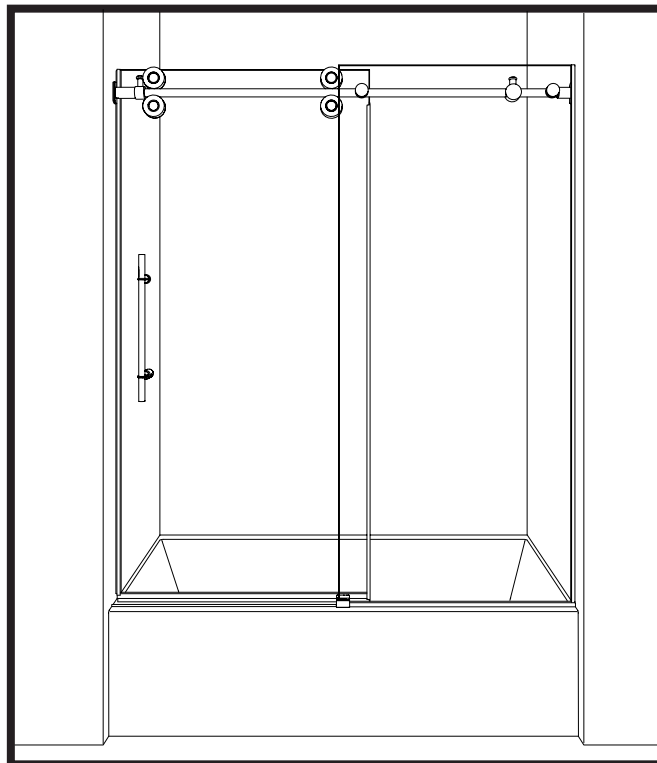

*TUB / BAIGNOIRE*

Please keep this manual and product code number for future reference  
and for ordering replacement parts if necessary.

*Veillez conserver ce manuel et le code de produit pour des références futures,  
et au besoin, la commande de pièces de rechange.*

#### GENERAL INSTRUCTIONS

- Read this manual carefully and completely before proceeding.
- It is recommended that you wear safety glasses at all times during the installation.

#### INSTALLATION OVER CERAMIC TILES

- If your shower door is to be installed over ceramic tiles, the tiles should lay completely under the wall jamb.
- Silicone should be used to seal the gap where the ceramic tiles meet the fixed panel.

#### NOTICE

- Caulking: no sealant is required inside the shower, unless otherwise stated.
- Some models are equipped with clear sealing gaskets.

#### CARE FOR YOUR SHOWER DOOR

- Never use scouring powder pads or sharp instruments on metal pieces or glass panels. An occasional wiping down with a mild soap diluted in water is all that is needed to keep the panels and aluminum parts looking new.
- We recommend wiping the glass panels with a squeegee after each use.

En

#### INSTRUCTIONS GÉNÉRALES

- Lire attentivement et complètement le manuel d'installation avant de procéder.
- Il est recommandé de porter des lunettes de sécurité en tout temps lors de l'installation.

#### INSTALLATION SUR LES TUILES EN CÉRAMIQUE

- Si votre porte de douche doit être installée sur une bordure en céramique, le jambage doit reposer complètement sur cette dernière.
- Le calfeutrage doit être appliqué sur le côté extérieur de la douche où le panneau fixe rencontre la bordure en céramique.

#### NOTE

- Calfeutrage: aucun scellant n'est nécessaire à l'intérieur de la douche.
- Certains modèles sont dotés de joints d'étanchéité clairs.

#### L'ENTRETIEN DE VOTRE DOUCHE

- Ne jamais utiliser de poudre ou de tampon à récurer, ni d'instrument tranchant sur les parties en métal ou en verre. De temps à autre, il suffit de nettoyer la porte avec une solution d'eau et un détergent doux pour conserver l'aspect neuf des panneaux de verre et du cadre en aluminium.
- Nous recommandons de passer une raclette de douche sur les panneaux de verre après chaque utilisation.

Fr

**TOOLS REQUIRED / OUTILS REQUIS**

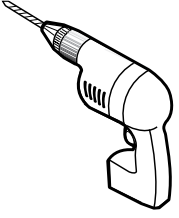

**DRILL**  
*PERCEUSE*

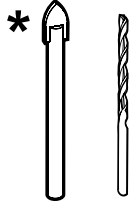

**1/4" & 1/8" DRILL BITS**  
*MÈCHE 1/4" & 1/8"*



**LOCKING PLIERS**  
*PINCE SERRE*



**SCREWDRIVER**  
*TOURNEVIS*

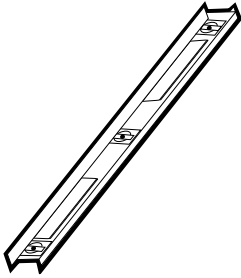

**LEVEL**  
*NIVEAU*

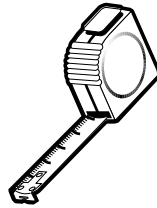

**TAPE MEASURE**  
*RUBAN À MESURER*

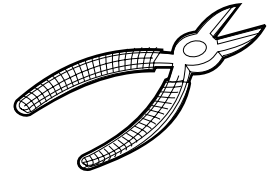

**CUTTING PLIER**  
*PINCE COUPANTE*



**PENCIL**  
*CRAYON*



**SAFETY GLASSES**  
*LUNETTES DE SÉCURITÉ*

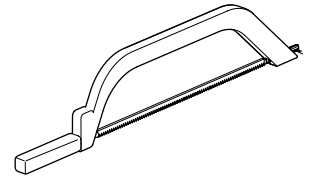

**HACKSAW**  
*SCIE À MÉTAUX*

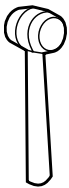

**MALLET**  
*MAILLET*



**BLOCK**  
*BLOC*

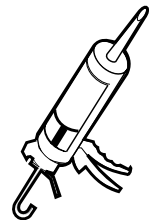

**SILICONE**  
*SCELLANT*

\* Use a 1/4" drill bit for ceramic when drilling into ceramic tiles

\* Utiliser une mèche de 1/4" destiné à céramique lors du perçage des tuiles en céramique.

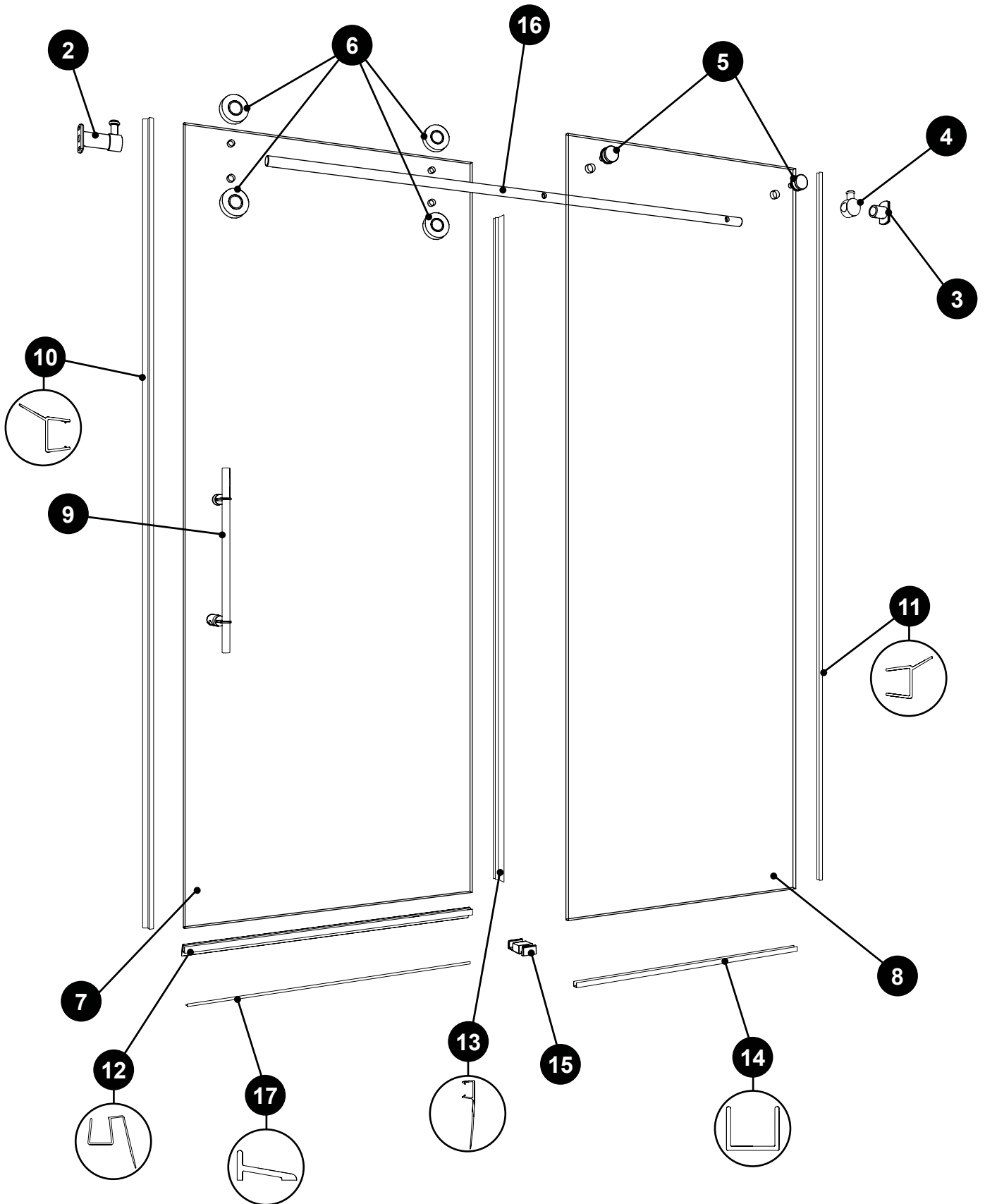

**PARTS AND HARDWARE LISTING / LISTE DES PIÈCES ET QUINCAILLERIE**

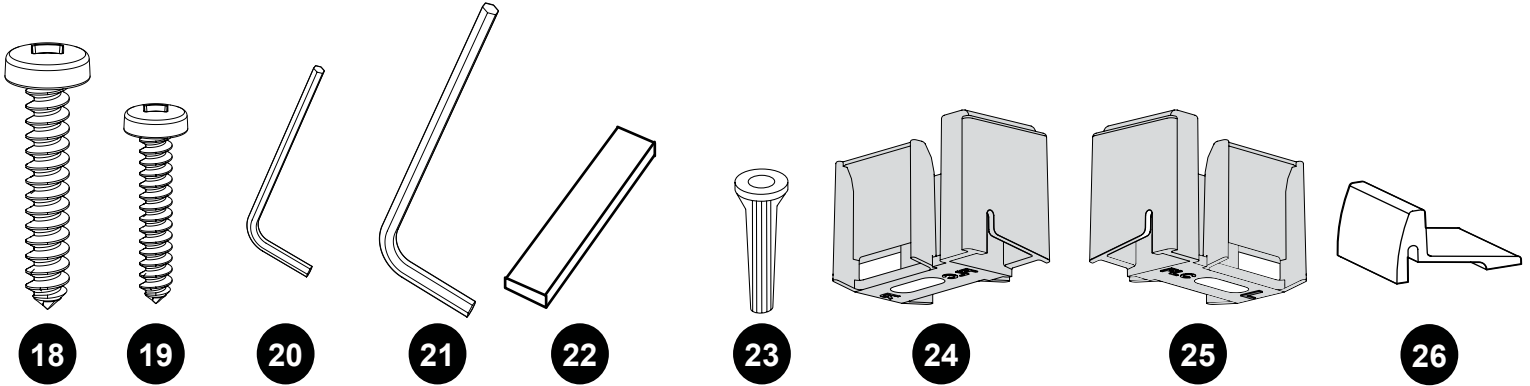

ITEM	PARTS AND HARDWARE / PIÈCES ET QUINCAILLERIE	QTY
1	RUNNING RAIL / BARRE DE ROULEMENT	1
2	WALL BRACKET WITH STOPPER / SUPPORTS MURAL AVEC BUTOIR	1
3	WALL BRACKET / SUPPORTS MURAL	1
4	STOPPER / BUTOIR	1
5	GLASS FASTENER / SUPPORT DE VERRE	2
6	ROLLER / ROULETTE	2 SET / PAIRS
7	DOOR PANEL / PANNEAU DE PORTE	1
8	FIXED PANEL / PANNEAU FIXE	1
9	HANDLE / POIGNÉE	1
10	DOOR PANEL GASKET / JOINT DE RÉTENTION POUR LA PORTE	1
11	FIXED PANEL GASKET / JOINT DE RÉTENTION POUR LA PORTE	1
12	DOOR BOTTOM SWEEP / JOINT INFÉRIEUR	1
13	CENTER GASKET / JOINT DU CENTRE	1
14	U-CHANNEL / PROFILE EN «U»	1
15	CENTER GUIDE / GUIDE DU CENTRE	1
16	RUNNING RAIL / BARRE DE ROULEMENT	1
17	THRESHOLD / SEUIL	1
18	#12-3 VIS AUTO-PERCANTE / #12-3 SELF-THREADING SCREW	4
19	#6-1 VIS AUTO-PERCANTE / #6-1 SELF-THREADING SCREW	2
20	HEX KEY 3mm	1
21	HEX KEY 6mm (7/32")	1
22	CLEAR SETTING BLOCK / BLOC NIVEAU TRANSPARENT	4
23	WALL PLUGS / CHEVILLES	2
24	PART B / PIÈCE B	1
25	PART A / PIÈCE A	1
26	THRESHOLD ANCHOR / ANCRAGE DU SEUIL	1

**CHOOSE A CONFIGURATION**  
**CHOISIR UNE CONFIGURATION**

**RIGHT SIDE INSTALLATION**  
**INSTALLATION DU CÔTÉ DROIT**

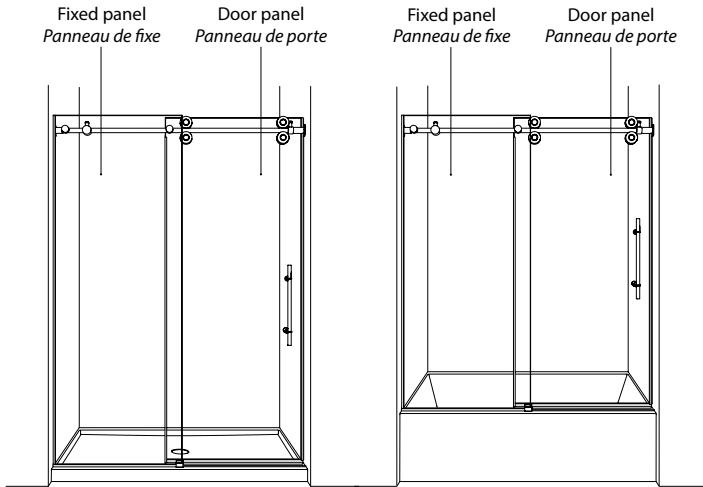

**LEFT SIDE INSTALLATION**  
**INSTALLATION DU CÔTÉ GAUCHE**

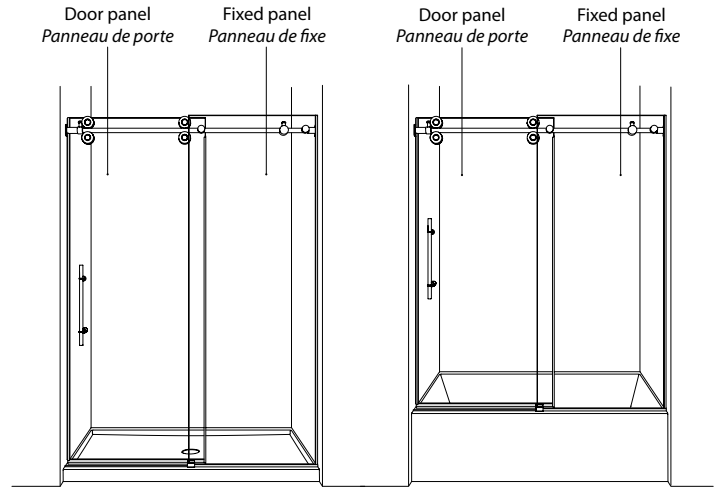

\* THIS CONFIGURATION IS ILLUSTRATED IN THIS MANUAL. FOLLOW THE SAME STEPS FOR THE TUB BASE.

\* CETTE CONFIGURATION EST ILLUSTRÉE DANS CE MANUEL. SUIVRE LES MÊMES ÉTAPES POUR LA BASE DE BAIGNOIRE.

**CHOOSE THE CORRECT PLASTIC PART CORRESPONDING TO YOUR CONFIGURATION**  
**CHOISIR LA PIÈCE EN PLASTIQUE CORRESPONDANT À VOTRE CONFIGURATION**

**PART B**  
**PIÈCE B**

CHOOSE THE PLASTIC PART (B) FOR RIGHT SIDE INSTALLATION.

CHOISIR LA PIÈCE EN PLASTIQUE (B) POUR INSTALLATION DU CÔTÉ DROIT.

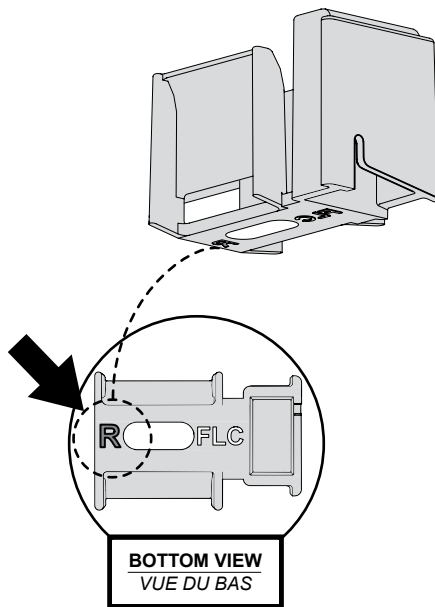

**PART A**  
**PIÈCE A**

CHOOSE THE PLASTIC PART (A) FOR LEFT SIDE INSTALLATION.

CHOISIR LA PIÈCE EN PLASTIQUE (A) POUR INSTALLATION DU CÔTÉ GAUCHE.

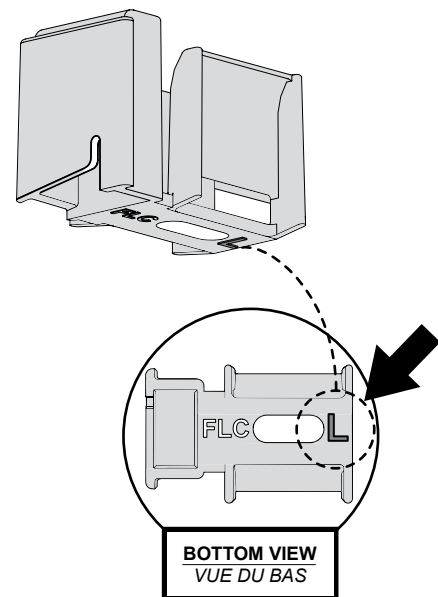

**INSERT THE PLASTIC PART INTO THE BOTTOM GUIDE**  
**INSÉRER LA PIÈCE EN PLASTIQUE DANS LE GUIDE INFÉRIEUR**

**RIGHT SIDE INSTALLATION**  
**INSTALLATION DU CÔTÉ DROIT**

**PART**  
**PIÈCE B**

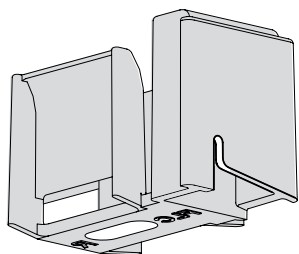

**!**

**INSERT THE RIGHT PLASTIC PART INTO THE BOTTOM GUIDE FROM BOTTOM**  
**INSÉRER LA PIÈCE DROITE EN PLASTIQUE SOUS LE GUIDE DU BAS**

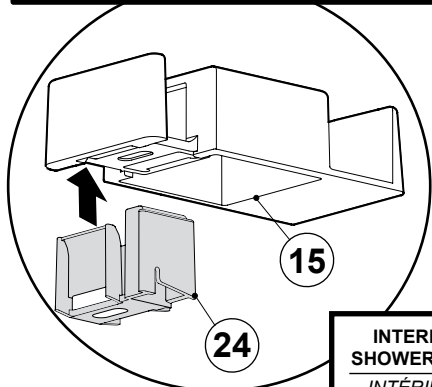

**INTERIOR**  
**SHOWER SIDE**  
**INTÉRIEUR**  
**DE LA DOUCHE**

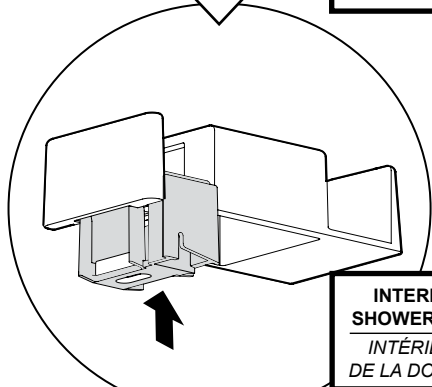

**INTERIOR**  
**SHOWER SIDE**  
**INTÉRIEUR**  
**DE LA DOUCHE**

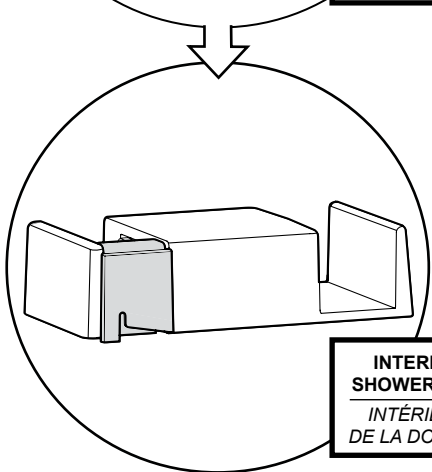

**INTERIOR**  
**SHOWER SIDE**  
**INTÉRIEUR**  
**DE LA DOUCHE**

**LEFT SIDE INSTALLATION**  
**INSTALLATION DU CÔTÉ GAUCHE**

**PART**  
**PIÈCE A**

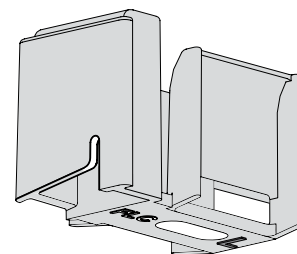

**!**

**INSERT THE LEFT PLASTIC PART INTO THE BOTTOM GUIDE FROM BOTTOM**  
**INSÉRER LA PIÈCE GAUCHE EN PLASTIQUE SOUS LE GUIDE DU BAS**

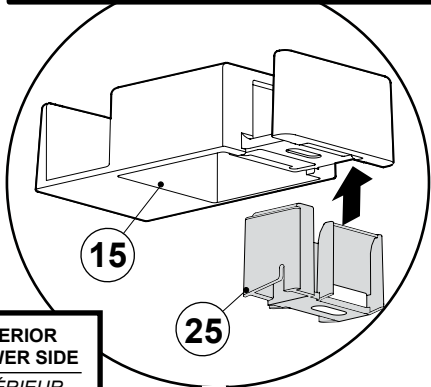

**INTERIOR**  
**SHOWER SIDE**  
**INTÉRIEUR**  
**DE LA DOUCHE**

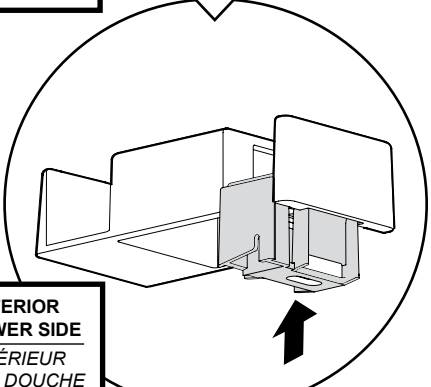

**INTERIOR**  
**SHOWER SIDE**  
**INTÉRIEUR**  
**DE LA DOUCHE**

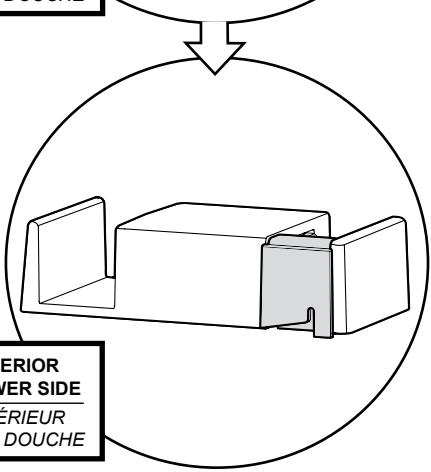

**INTERIOR**  
**SHOWER SIDE**  
**INTÉRIEUR**  
**DE LA DOUCHE**

**PLACE THE BOTTOM GUIDE ON THE BASE**  
**PLACER LE GUIDE INFÉRIEUR SUR LA BASE**



THE INSTALLATION SHOWN IS BASED ON PLUMB FINISHED WALLS AND A LEVELLED BASE. IF THESE CONDITIONS ARE NOT MET, PLEASE ADJUST ACCORDINGLY.

L'INSTALLATION ILLUSTRÉE EST BASÉE SUR DES MURS FINIS D'APLOMB ET UNE BASE DE DOUCHE NIVELÉE. SI CES CONDITIONS NE SONT PAS PRÉSENTES, VEUILLEZ AJUSTER EN CONSÉQUENCE.

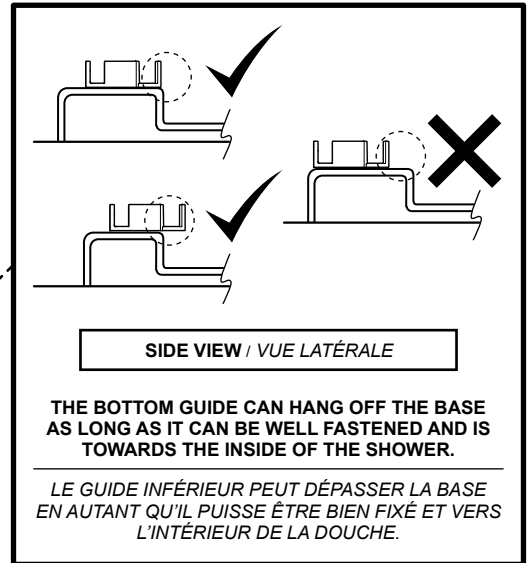

SIDE VIEW / VUE LATÉRALE

THE BOTTOM GUIDE CAN HANG OFF THE BASE AS LONG AS IT CAN BE WELL FASTENED AND IS TOWARDS THE INSIDE OF THE SHOWER.

LE GUIDE INFÉRIEUR PEUT DÉPASSER LA BASE EN AUTANT QU'IL PUISSE ÊTRE BIEN FIXÉ ET VERS L'INTÉRIEUR DE LA DOUCHE.

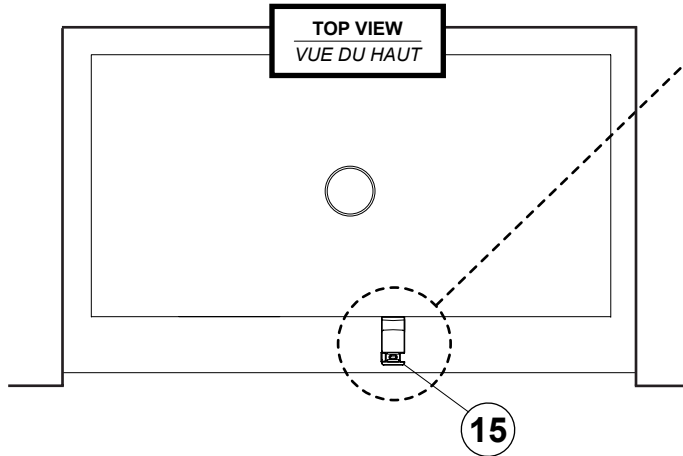

15

**PLACE THE U-CHANNEL**  
**PLACER LE PROFILÉ EN «U»**

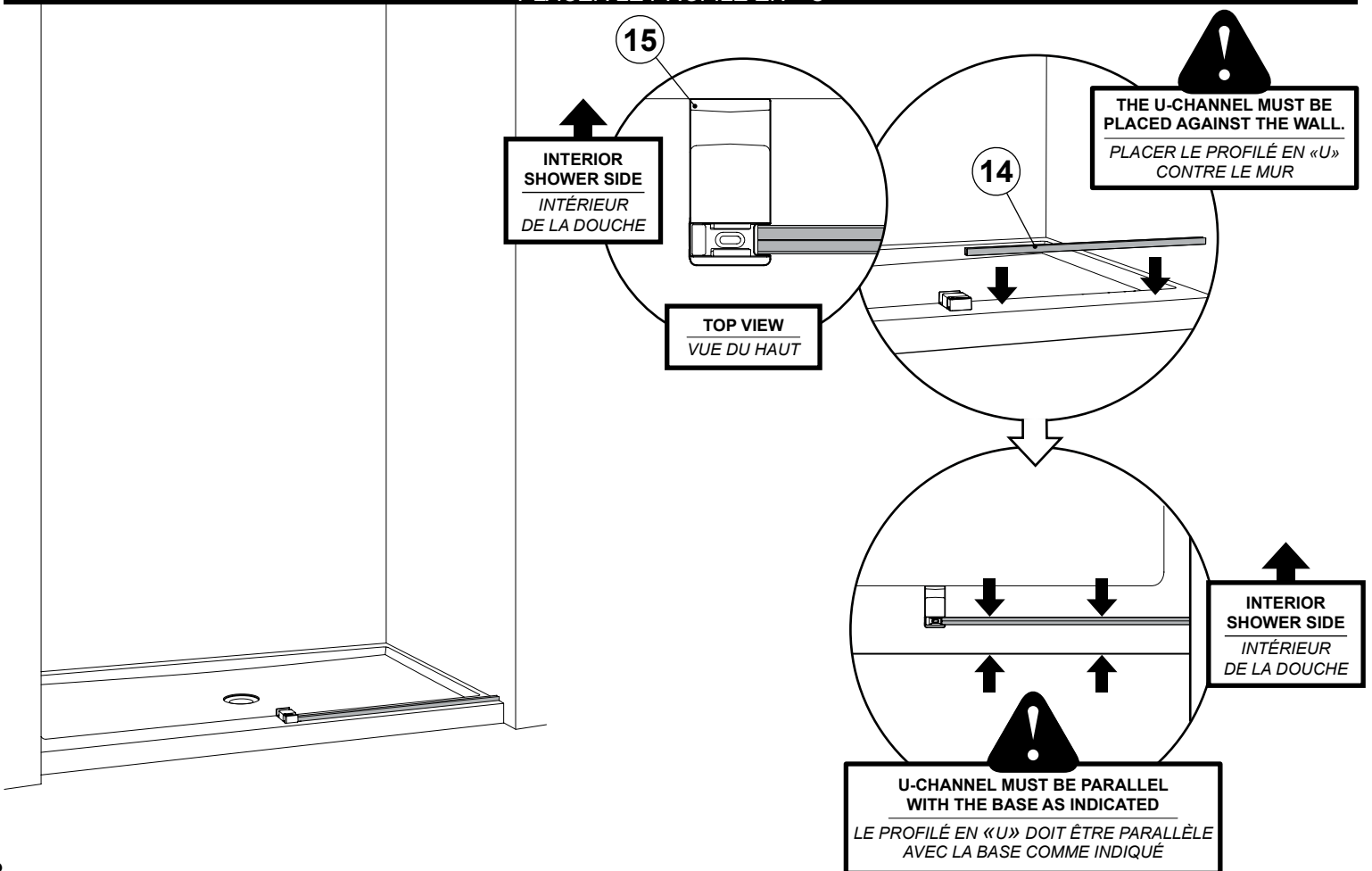

THE U-CHANNEL MUST BE PLACED AGAINST THE WALL.

PLACER LE PROFILÉ EN «U» CONTRE LE MUR

INTERIOR SHOWER SIDE  
 INTÉRIEUR DE LA DOUCHE

TOP VIEW  
 VUE DU HAUT

INTERIOR SHOWER SIDE  
 INTÉRIEUR DE LA DOUCHE

U-CHANNEL MUST BE PARALLEL WITH THE BASE AS INDICATED

LE PROFILÉ EN «U» DOIT ÊTRE PARALLÈLE AVEC LA BASE COMME INDIQUÉ



**MARK THE PLACEMENT OF THE U-CANNEL AND BOTTOM GUIDE**  
**MARQUER L'EMPLACEMENT DU PROFILÉ EN «U» ET DU GUIDE INFÉRIEUR**

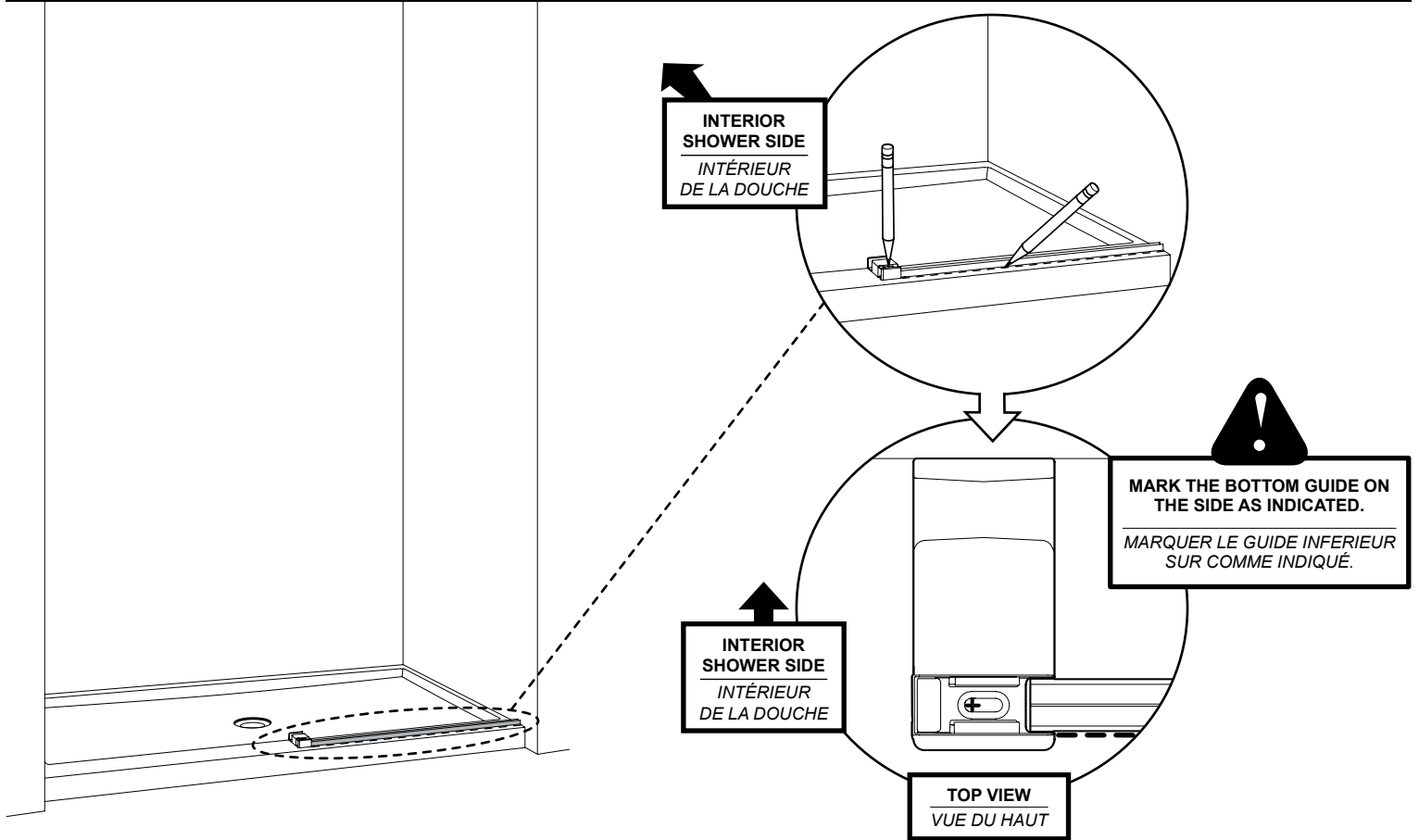

**DRILL AND SILICONE THE BOTTOM GUIDE PLACEMENT**  
**PERCER ET CALFEUTRER L'EMPLACEMENT DU GUIDE INFÉRIEUR**

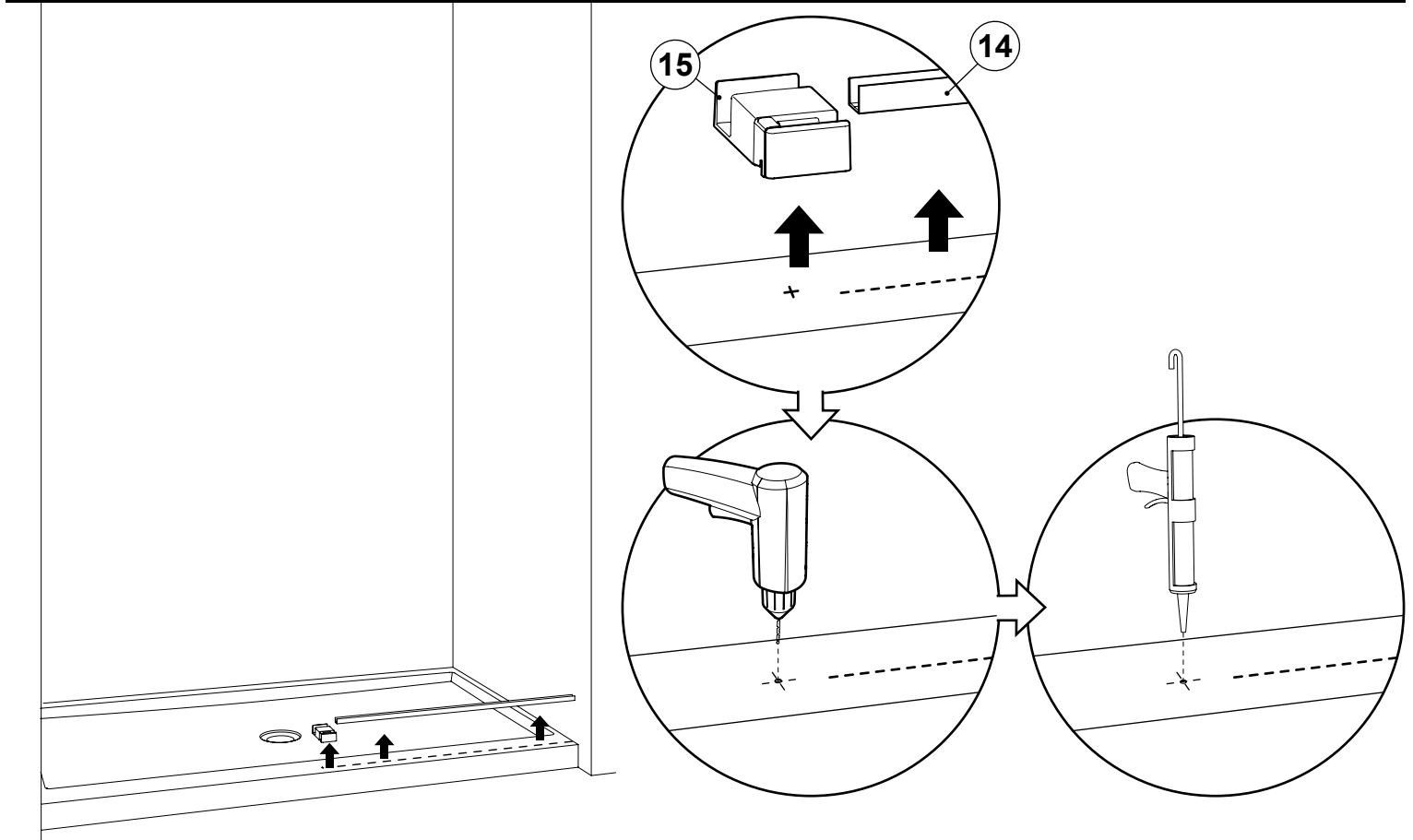

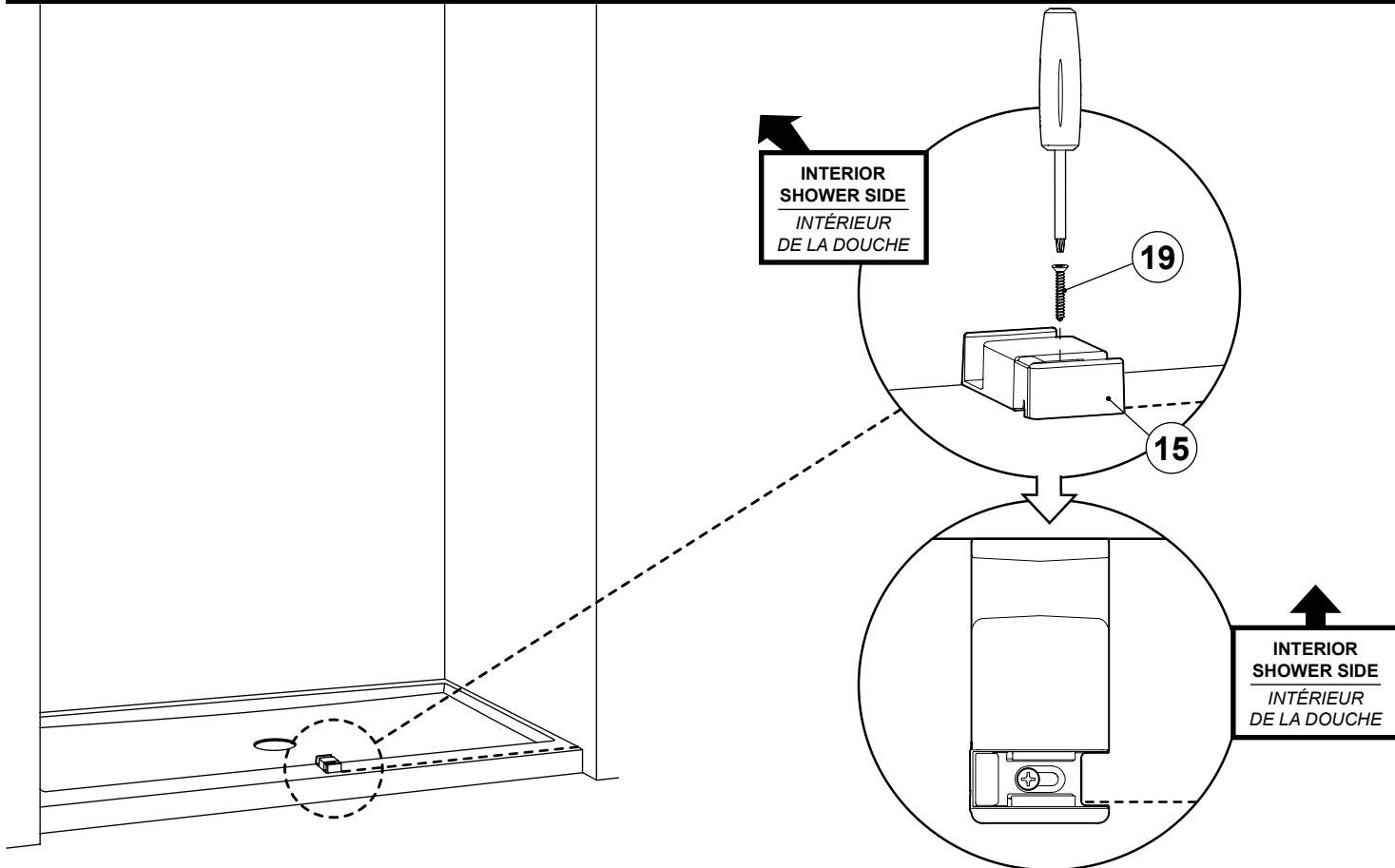

**INSTALL THE BOTTOM GUIDE**  
**INSTALLER LE GUIDE INFÉRIEUR**



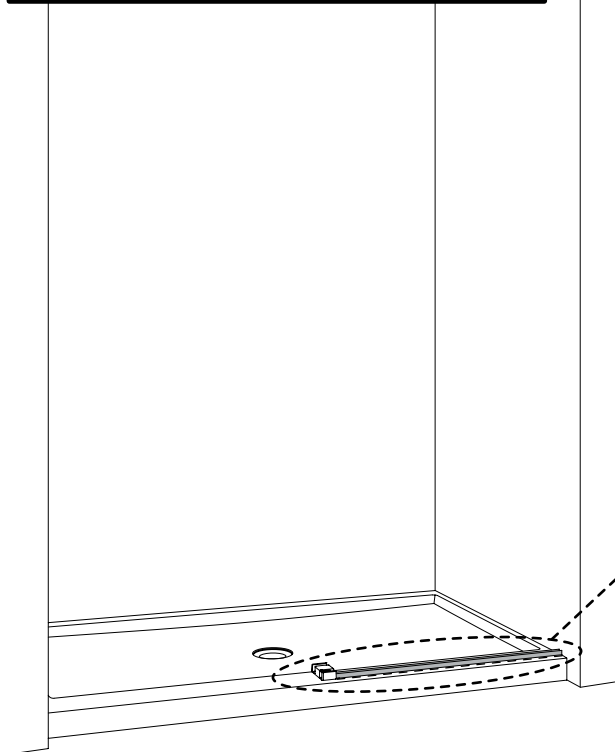

**INSTALL THE U-CHANNEL ON THE LOCATION MARKED PREVIOUSLY**  
**INSTALLER LE PROFILÉ EN «U» SUR LA PLACE MARQUÉE PRÉCÉDEMMENT**

 **WIPE THE BASE WITH A CLEAN CLOTH BEFORE INSTALLING THE U-CHANNEL.**  
*ESSUYER LA BASE AVEC UN CHIFFON PROPRE AVANT D'INSTALLER LE PROFILÉ EN «U».*

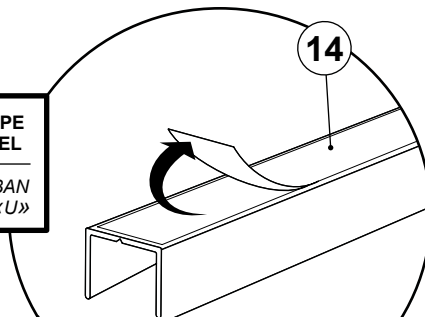

 **REMOVE THE TAPE FROM U-CHANNEL**  
*ENLEVER LE RUBAN DU PROFILÉ EN «U»*



 **PLACE TWO CLEAR SETTING BLOCKS IN U-CHANNEL**  
 *PLACER DEUX BLOCS DE NIVEAU TRANSPARENTS DE DANS LE PROFILÉ EN «U»*

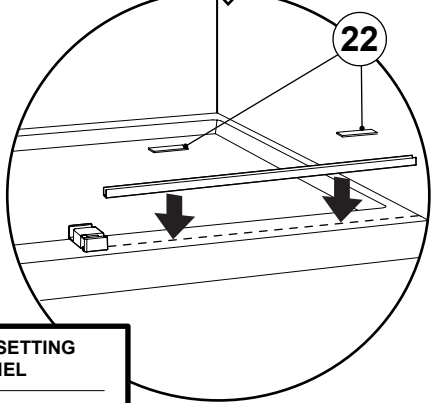

**INSTALL THE BOTTOM DOOR GASKET**  
**INSTALLER LE JOINT INFÉRIEUR POUR LA PORTE**

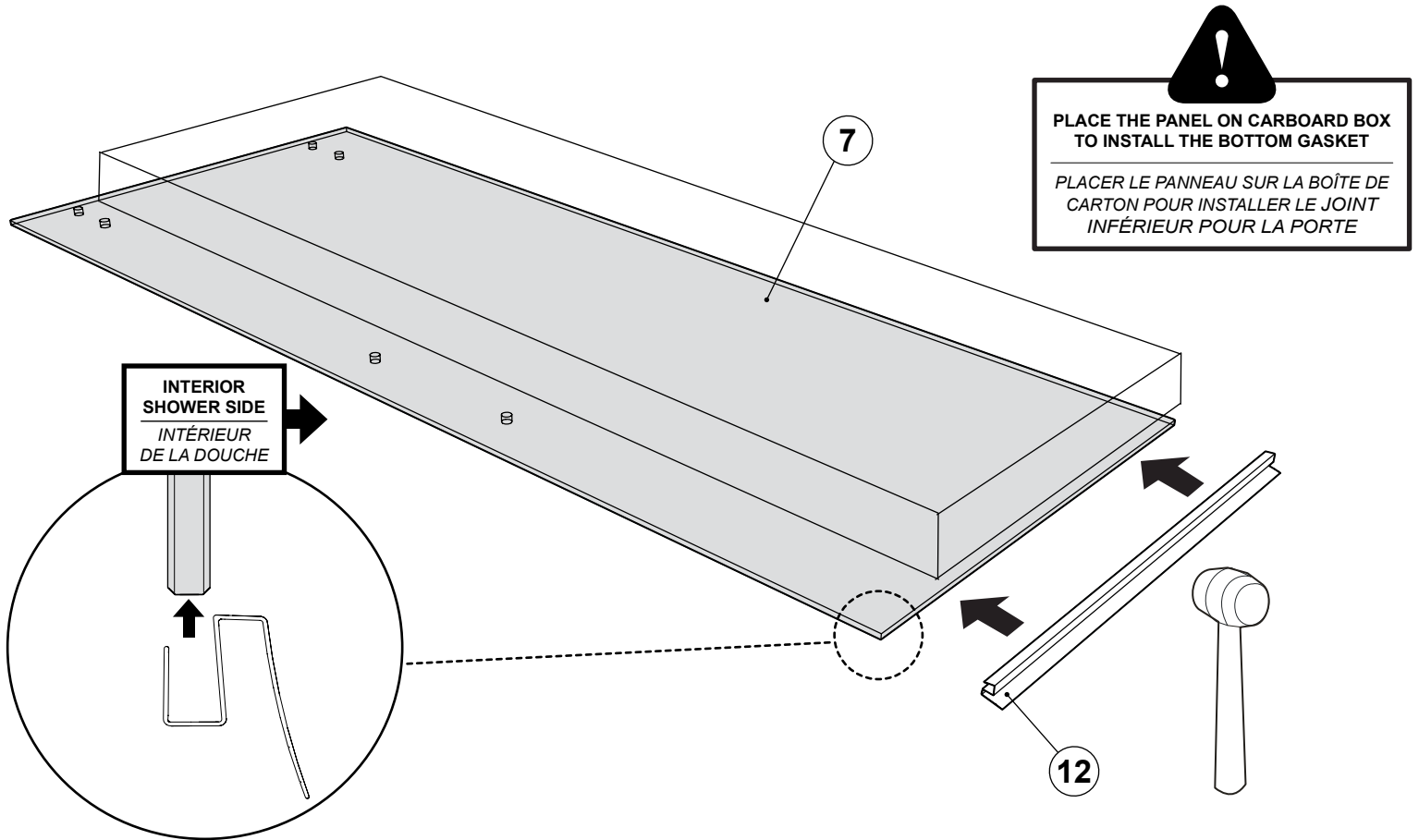

**INSTALL TWO ROLLERS ON THE DOOR PANEL**  
**INSTALLER DEUX ROULETTES SUR LE PANNEAU DE PORTE**

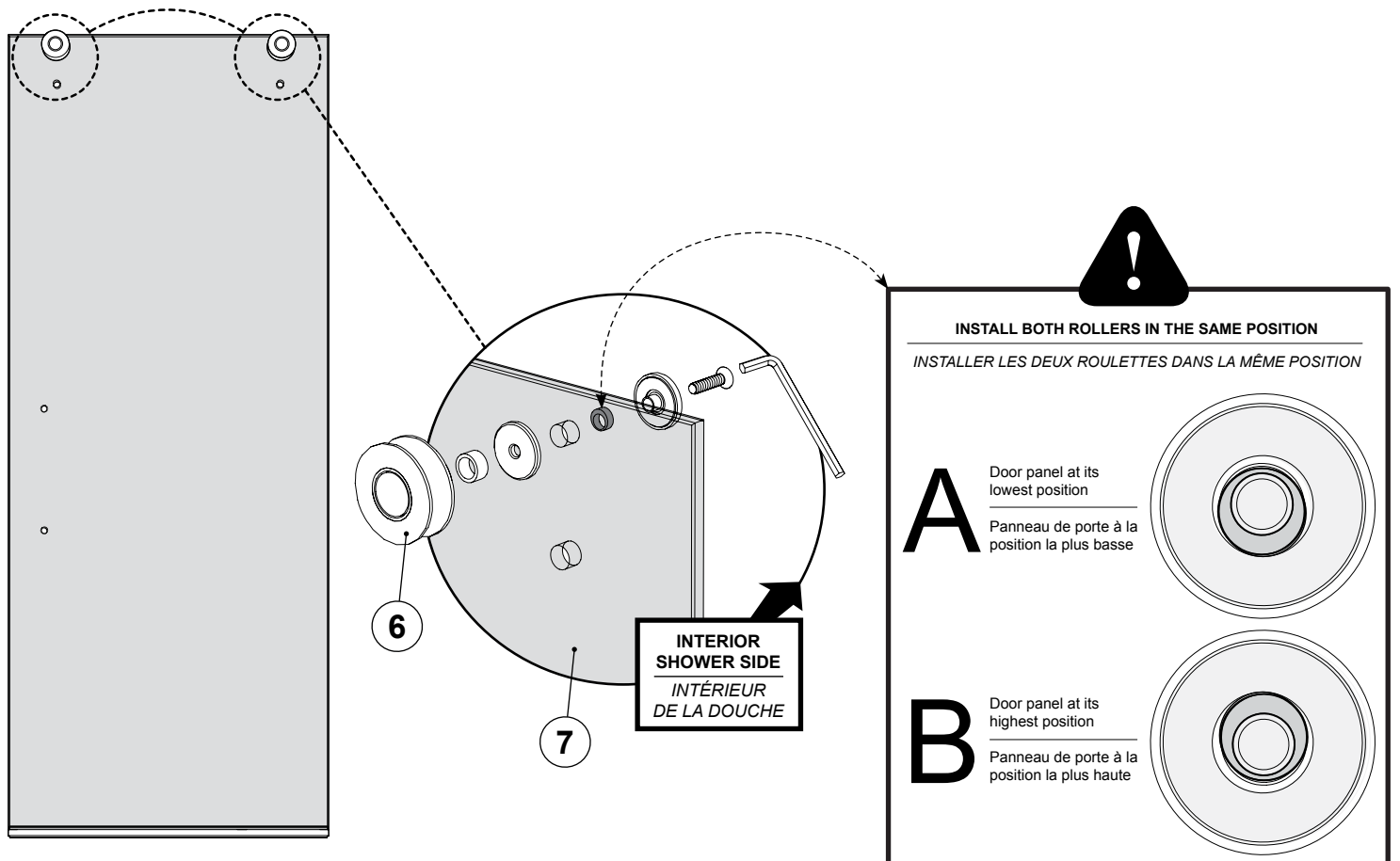

**INSTALL THE SIDE DOOR PANEL GASKET**  
**INSTALLER LE JOINT LATÉRAL DE LA PORTE**

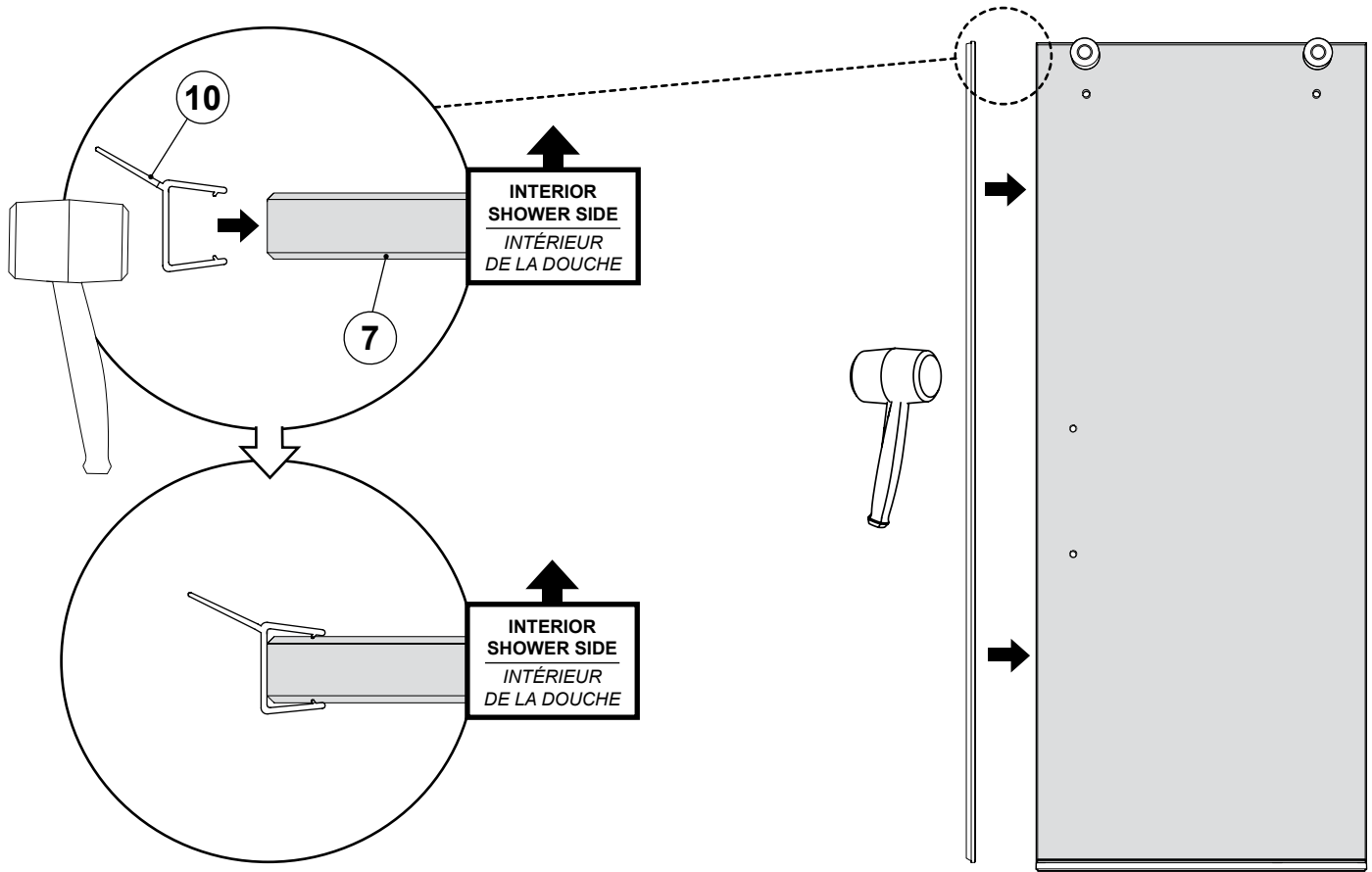

**INSTALL THE DOOR HANDLE**  
**INSTALLER LA POIGNÉE DE PORTE**

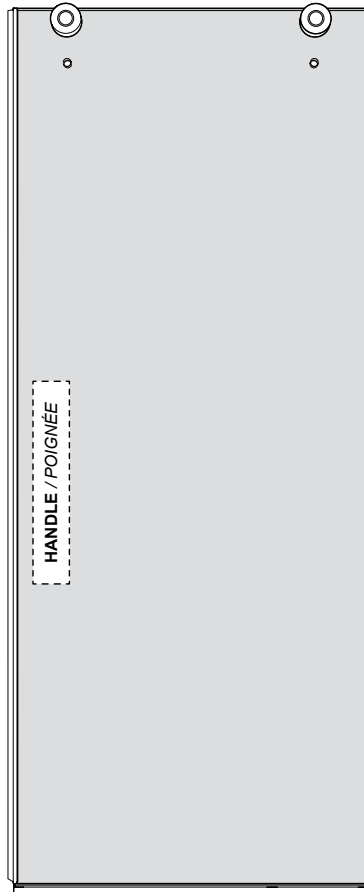

  
**SEE INSTRUCTIONS ENCLOSED WITH THE HANDLE FOR INSTALLATION PROCEDURES.**  
*VOIR LES INSTRUCTIONS QUI SONT ENFERMÉS AVEC LA POIGNÉE POUR LES PROCÉDURES D'INSTALLATION.*

**PLACE THE DOOR PANEL INSIDE THE SHOWER**  
**PLACER LE PANNEAU DE PORTE DANS LA DOUCHE**



**PLACE THE DOOR ON A TOWEL TO PREVENT  
SCRATCHING THE SHOWER BASE**

*PLACER LA PORTE SUR UNE SERVIETTE  
POUR ÉVITER DE RAYER LA BASE DE DOUCHE*

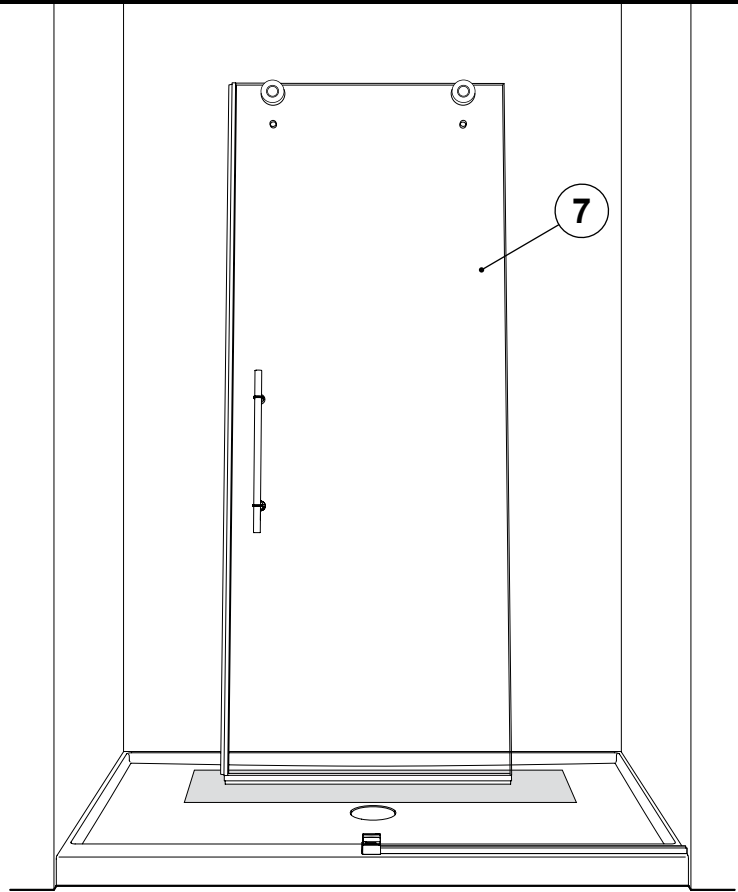

**INSTALL THE FIXED PANEL GASKET**  
**INSTALLER LE JOINT LATÉRAL SUR LE PANNEAU FIXE**

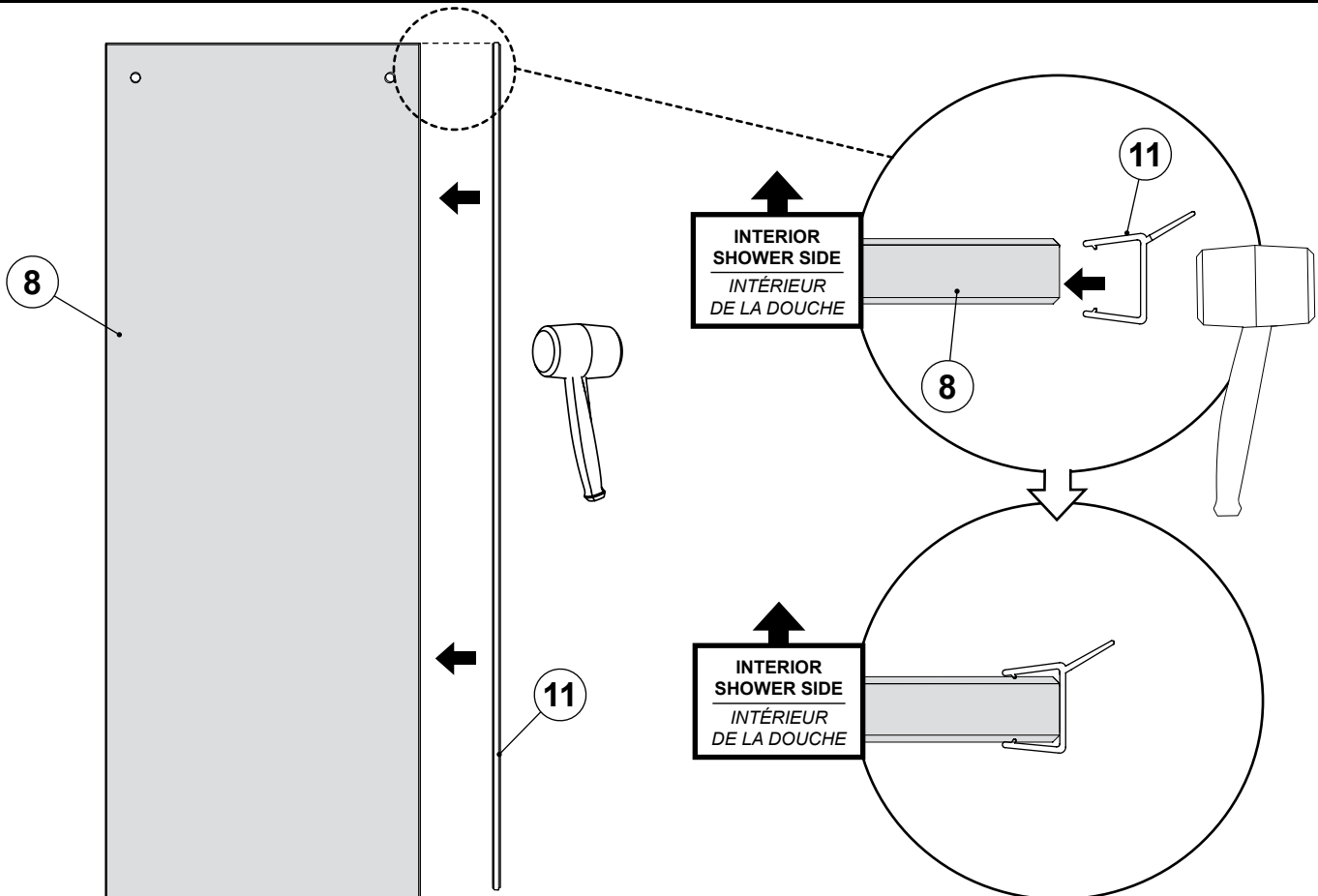

**INSTALL THE STOPPERS**  
*INSTALLER LES BUTIORS*

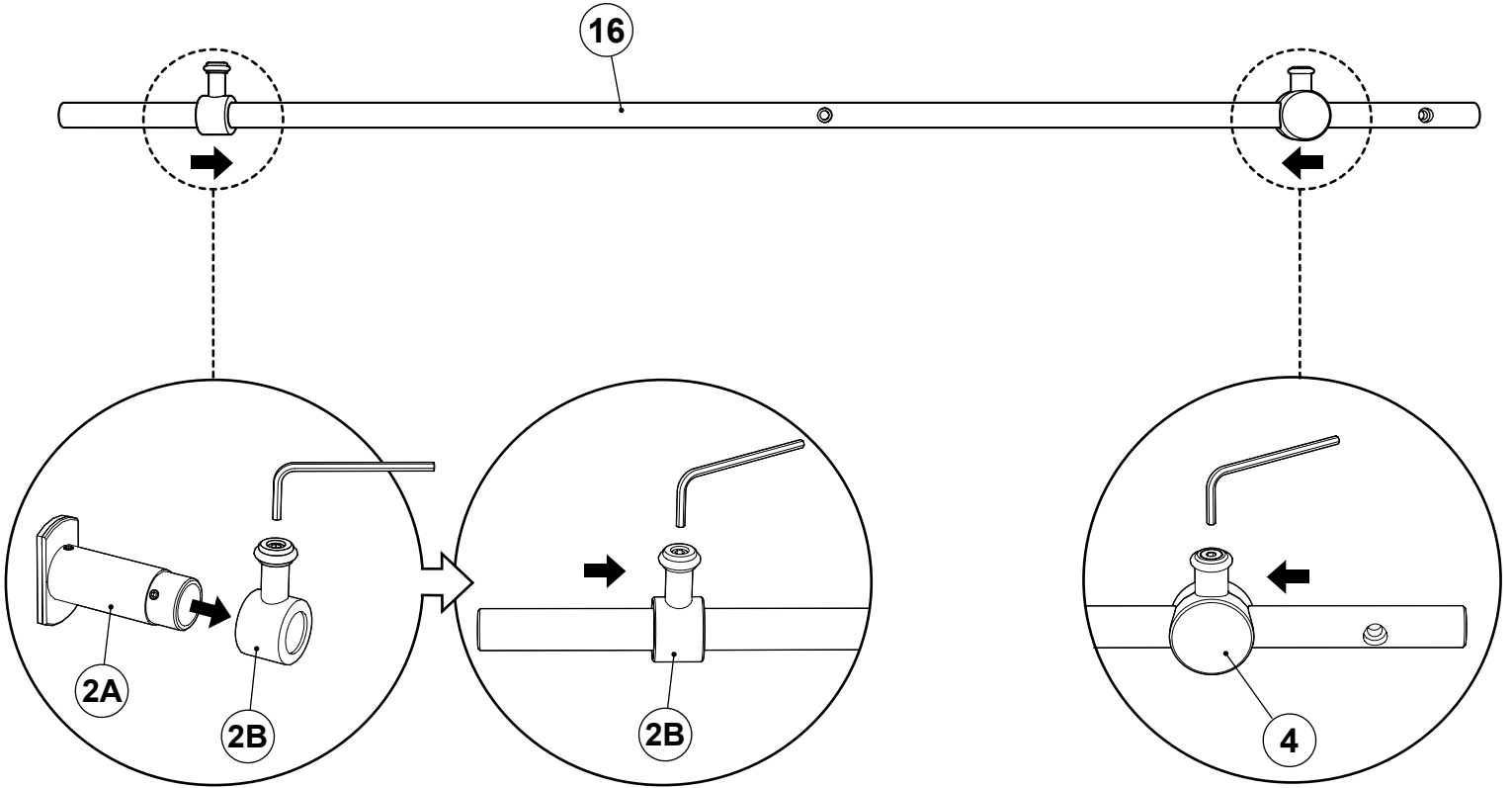

**INSTALL THE WALL MOUNT BRACKETS**  
*INSTALLER LES SUPPORTS MURAUX*

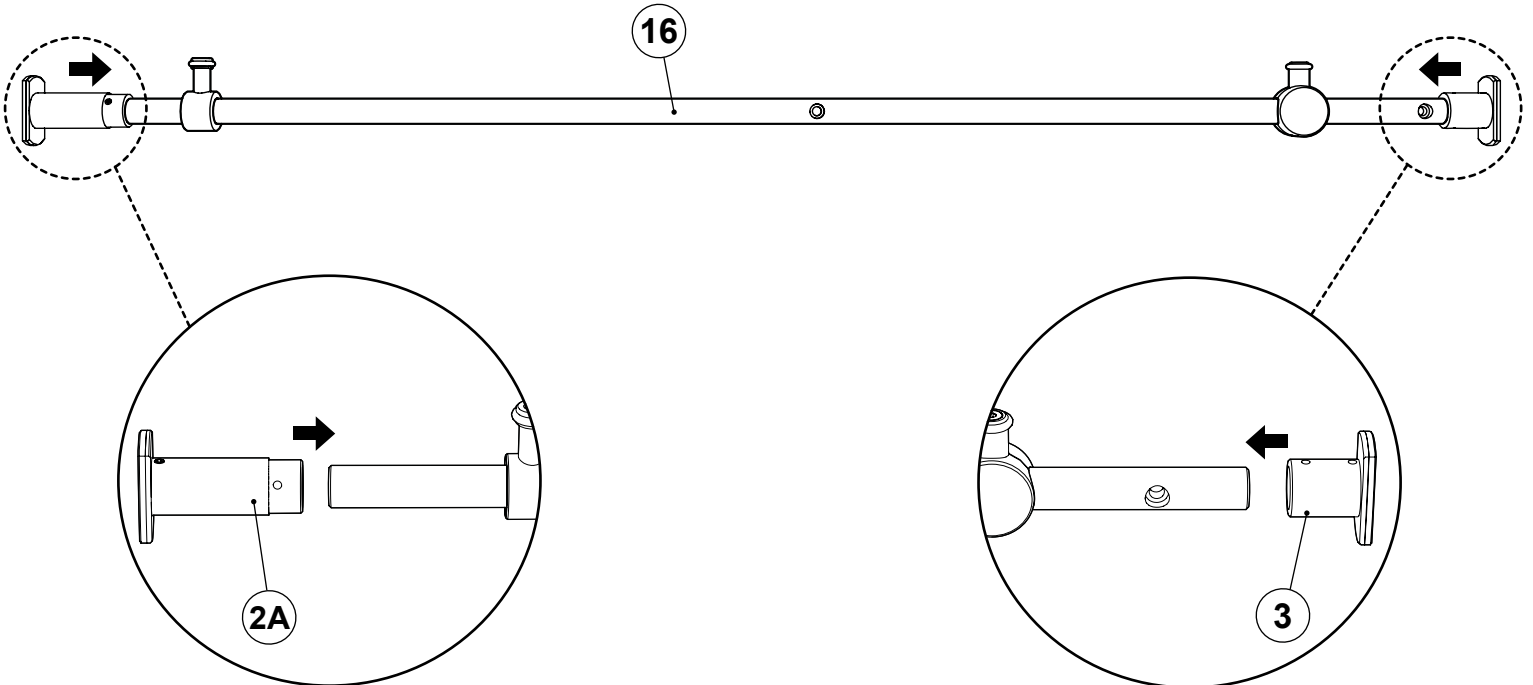

**INSTALL THE RUNNING RAIL TO THE FIXED PANEL USING THE GLASS FASTENERS**  
**INSTALLER LE RAIL DE ROULEMENT AU PANNEAU FIXE EN UTILISANT LES SUPPORTS DE VERRE**

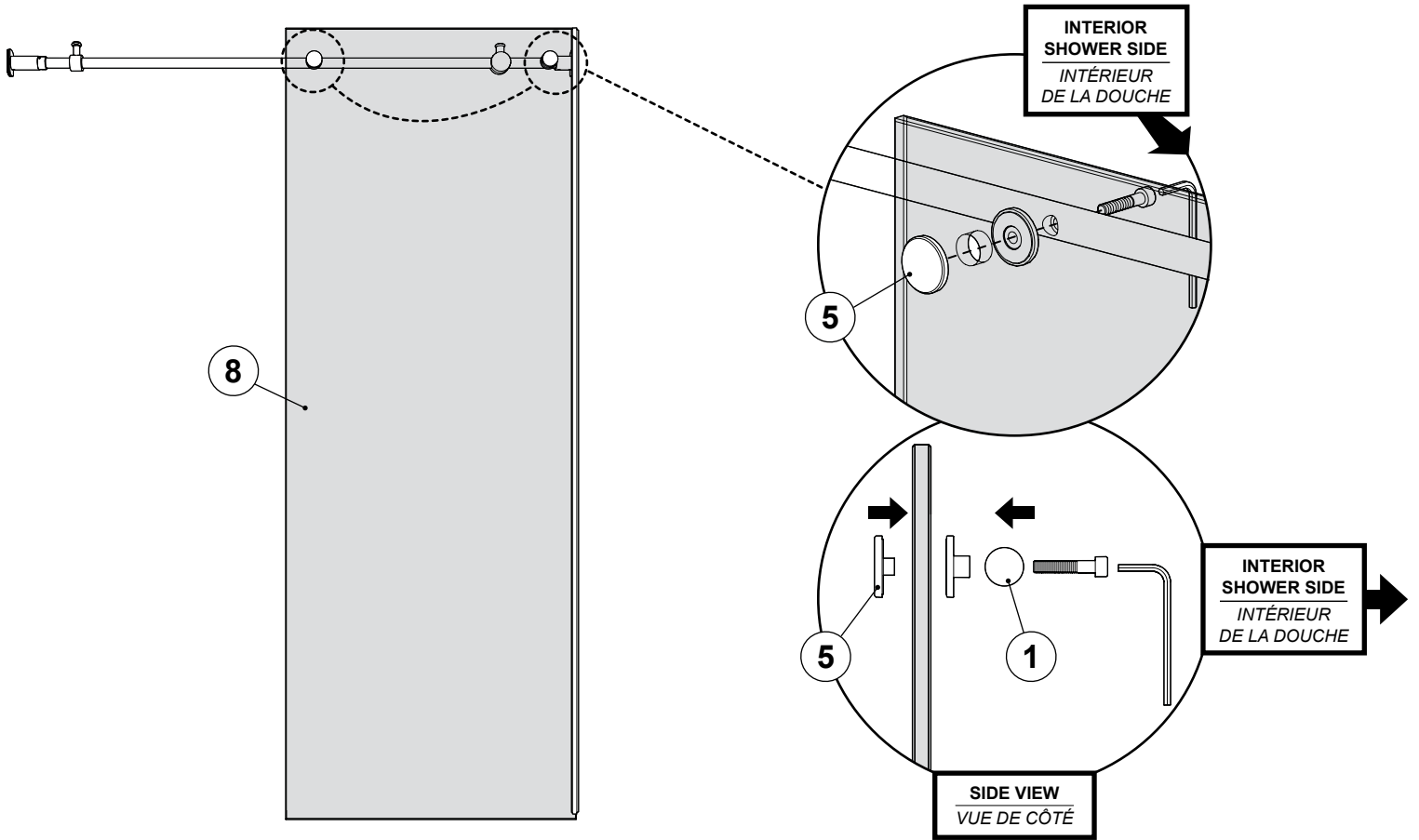

**INSERT THE FIXED PANEL INTO THE U-CHANNEL**  
**INSÉRER LE PANNEAU FIXE DANS LE PROFILÉ EN «U»**

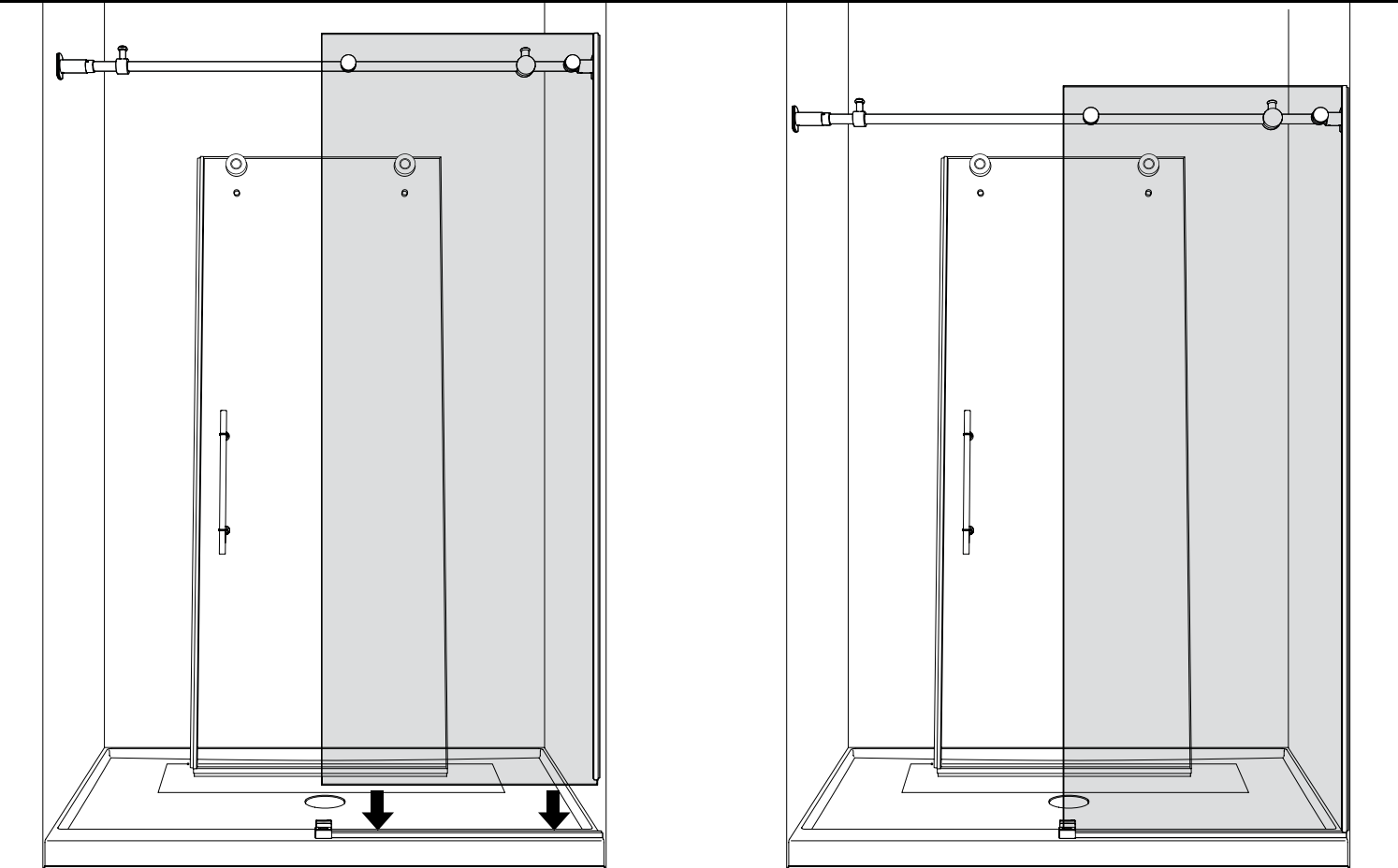

**LEVEL THE FIXED PANEL**  
**NIVELER LE PANNEAU FIXE**

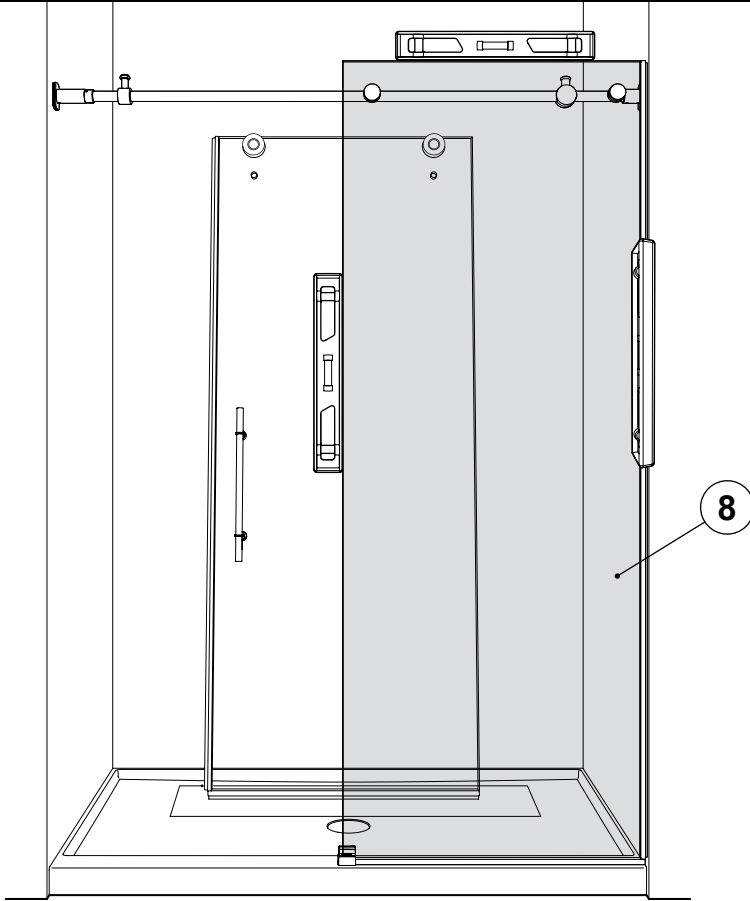

**IF PANEL IS NOT LEVEL ADD CLEAR SETTING BLOCKS 1/8" OR 1/16".**

*SI LE PANNEAU N'EST PAS NIVELÉ, AJOUTER LES BLOCS DE NIVEAU TRANSPARENTS 1/8" OU 1/16"*

**LEVEL THE RUNNING RAIL BY ADJUSTING THE GLASS FASTENERS**

**NIVELER LA BARRE DE ROULEMENT EN AJUSTANT LES SUPPORTS DE VERRE**

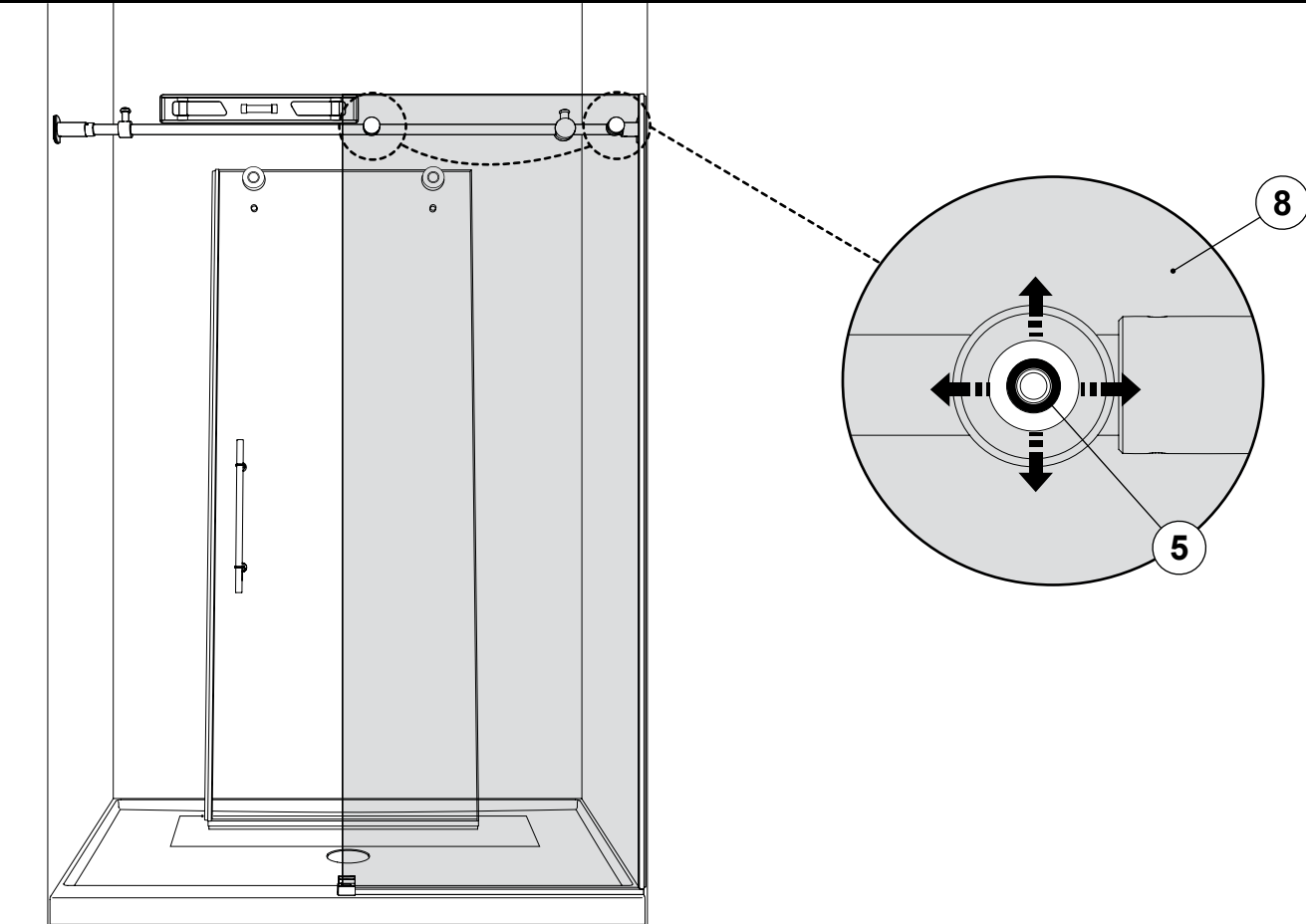



**PUSH THE WALL MOUNT BRACKETS AGAINST THE WALL AND MARK THEIR LOCATIONS**  
**POUSSER LES SUPPORTS MURAUX CONTRE LE MUR ET MARQUER LEURS EMPLACEMENTS**

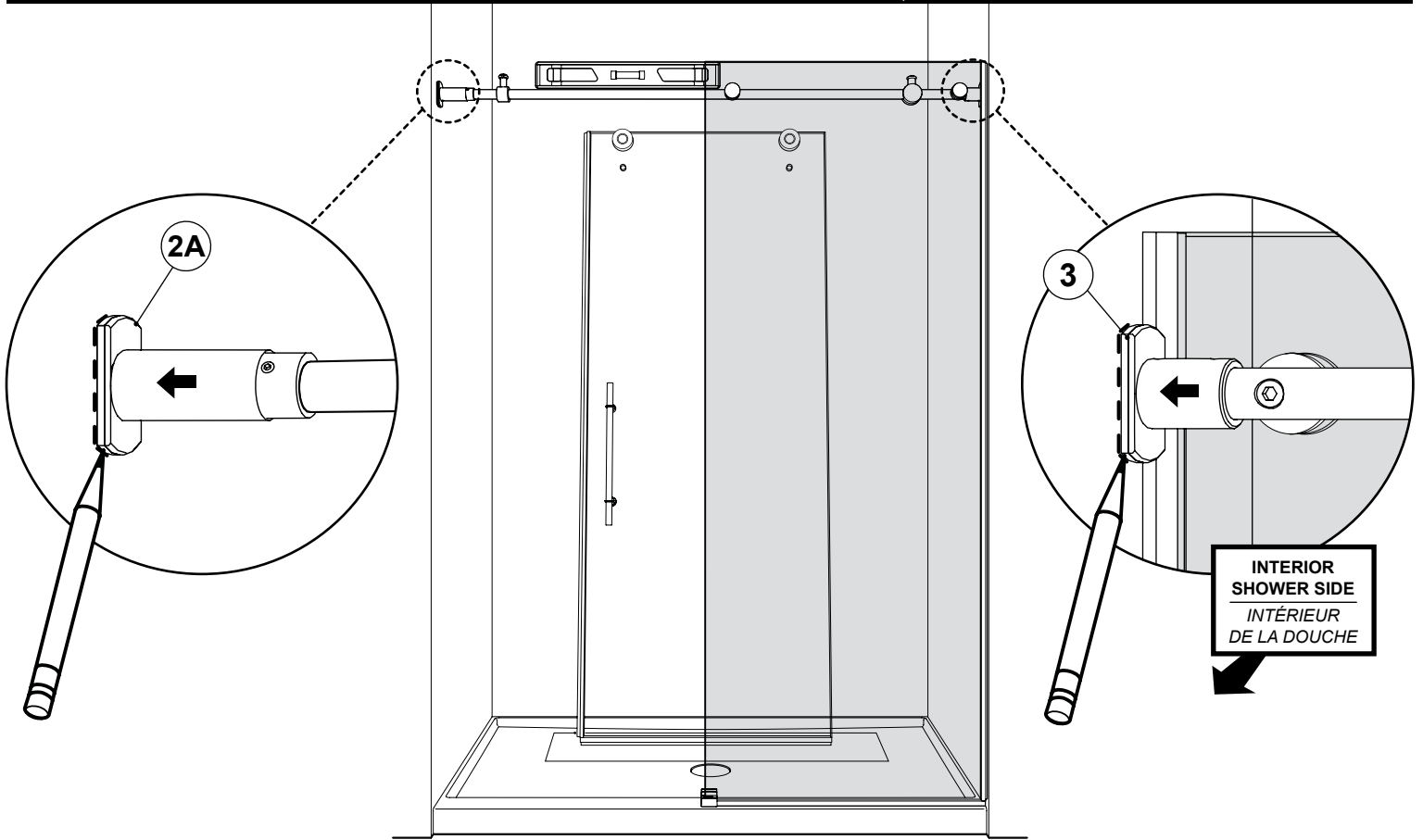

**REMOVE THE FIXED PANEL**  
**RETIRER LE PANNEAU FIXE**

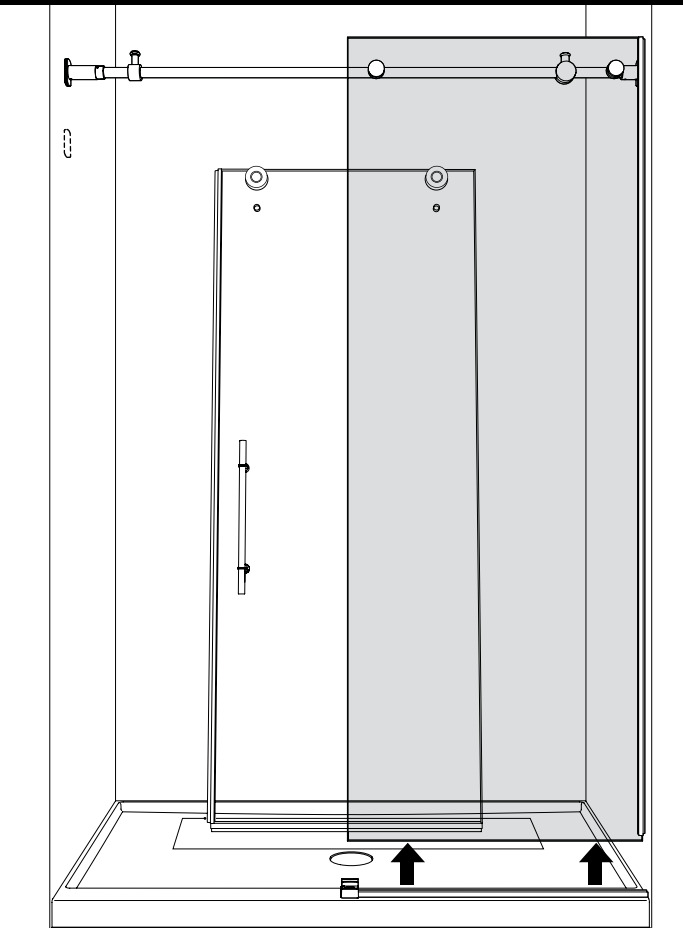

**REMOVE THE BACKPLATES FROM THE WALL MOUNTS BRACKET**  
*RETIRER LA PLAQUE ARRIÈRE DES SUPPORT MURAUX*

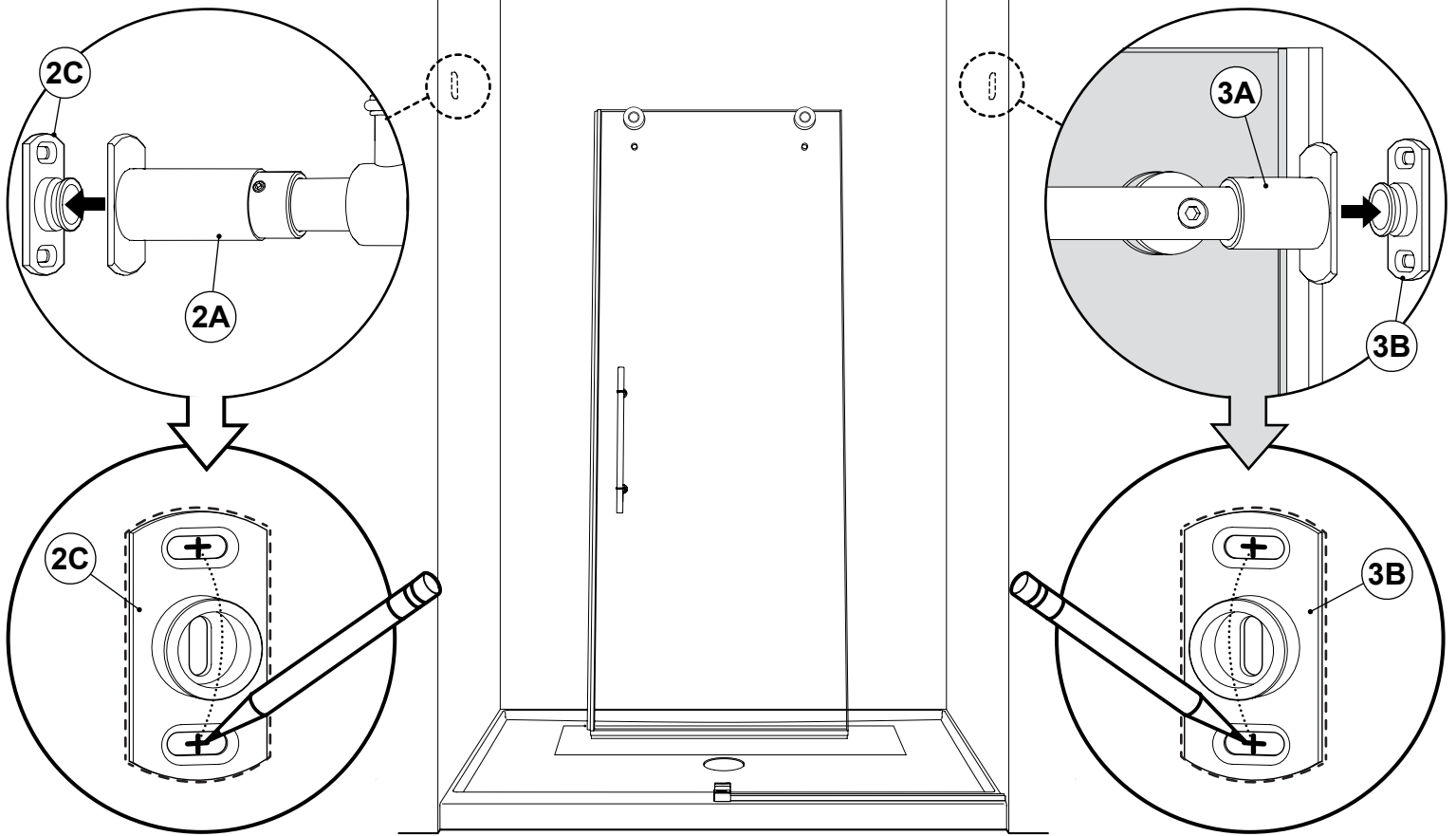

**INSTALL THE BACKPLATES OF THE WALL MOUNTS**  
*INSTALLER LA PLAQUES ARRIÈRES DES SUPPORTS MURAUX*

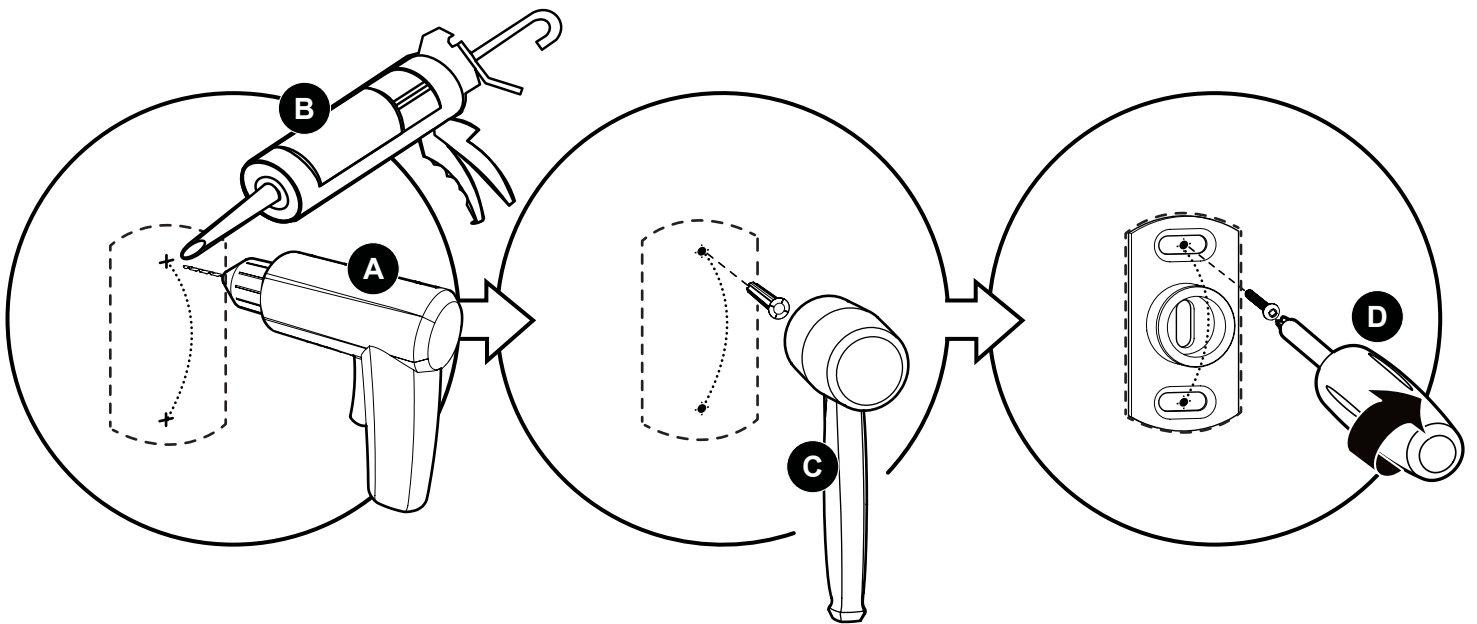

**REINSTALL THE FIXED PANEL**  
**REINSTALLER LE PANNEAU FIXE**

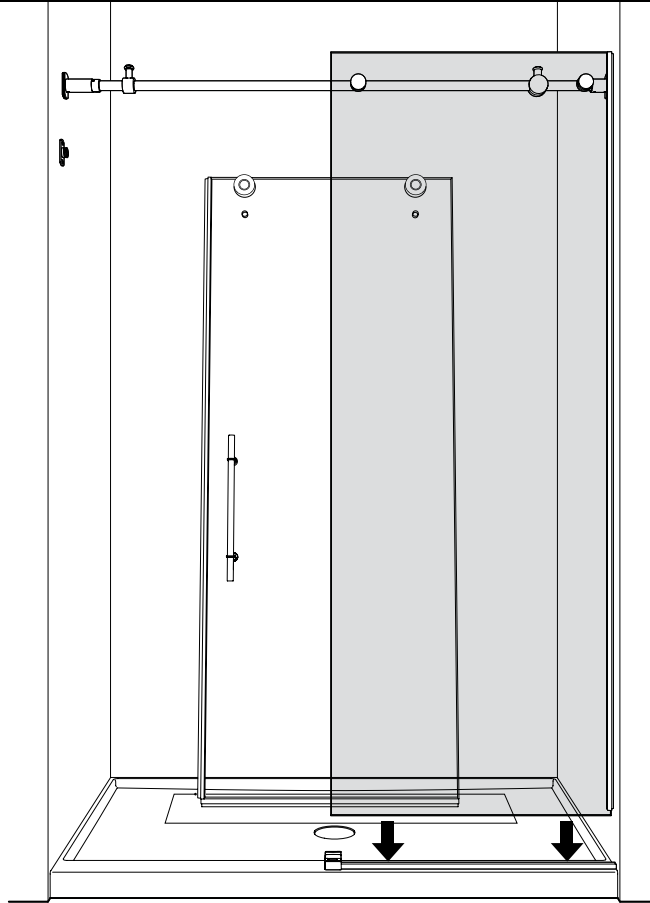

**SECURE THE BACKPLATE TO THEIR WALL MOUNTS**  
**SÉCURISER LES PLAQUES ARRIÈRE À LEURS SUPPORTS MURAUX**

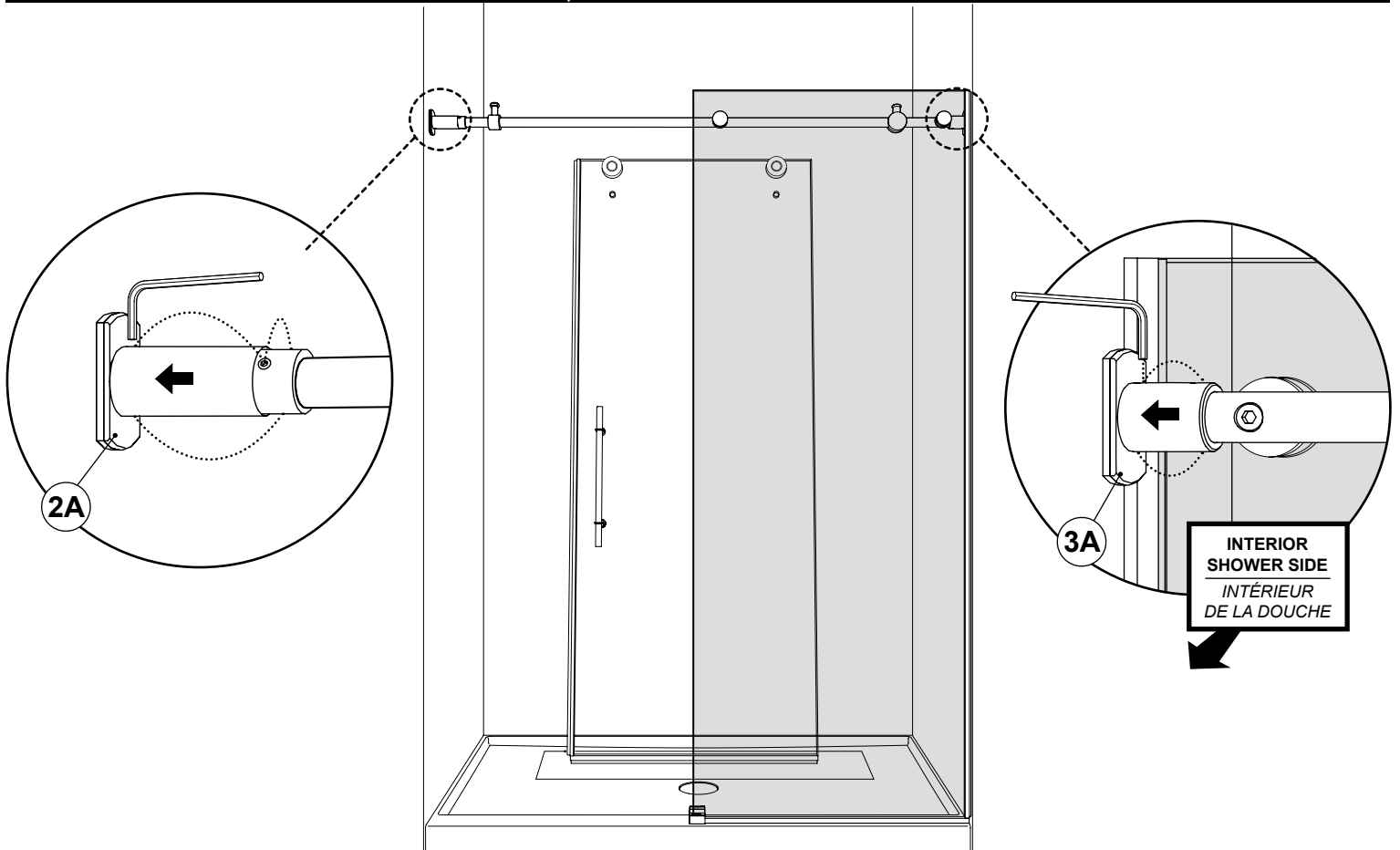

**POSITION THE STOPPER**  
**POSITIONNER LE BUTOIR**

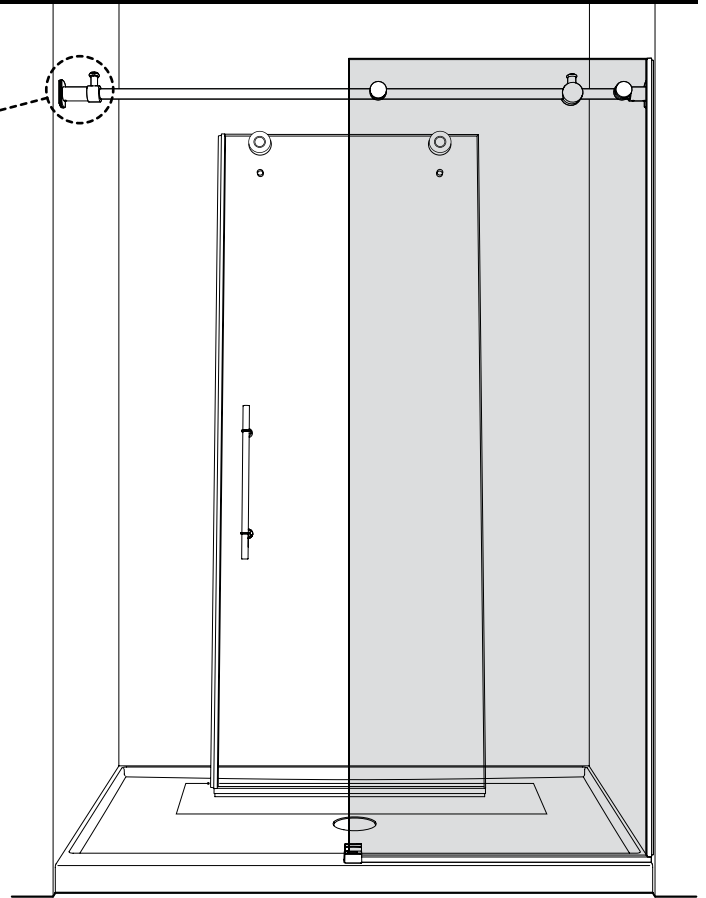
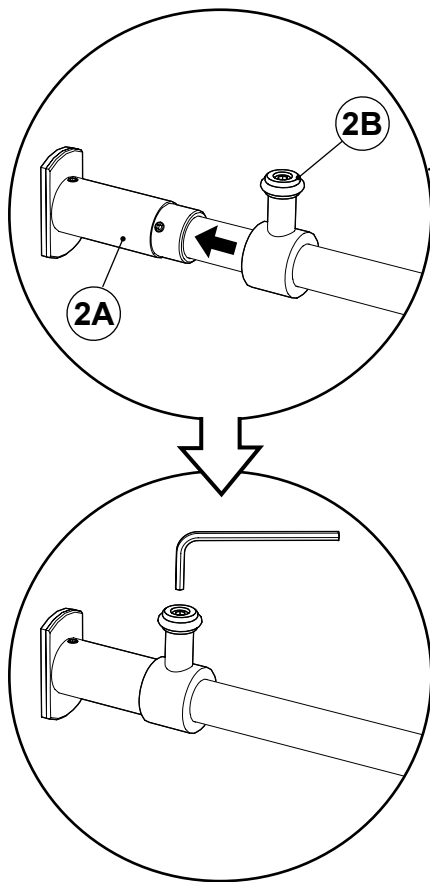

**INSTALL THE DOOR PANEL**  
**INSTALLER LE PANNEAU DE PORTE**

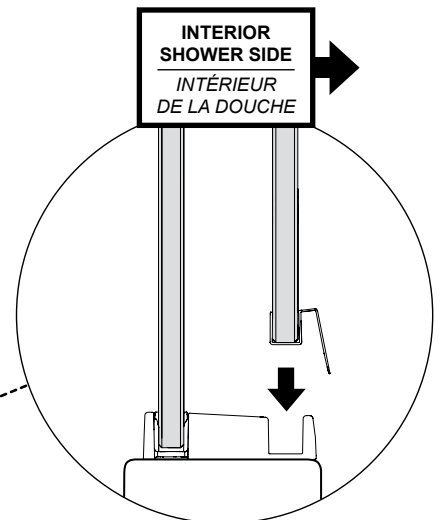
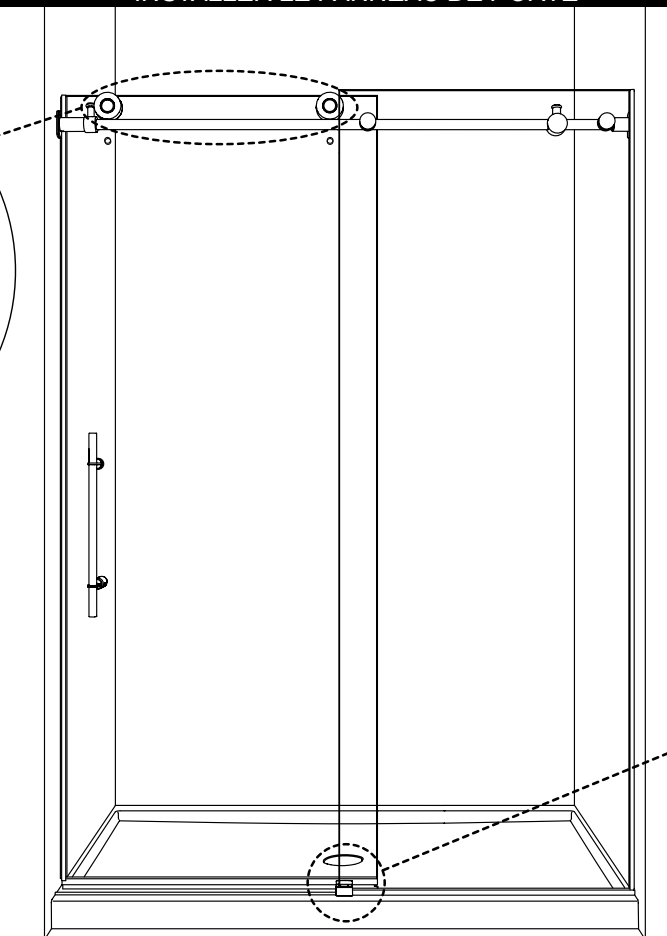
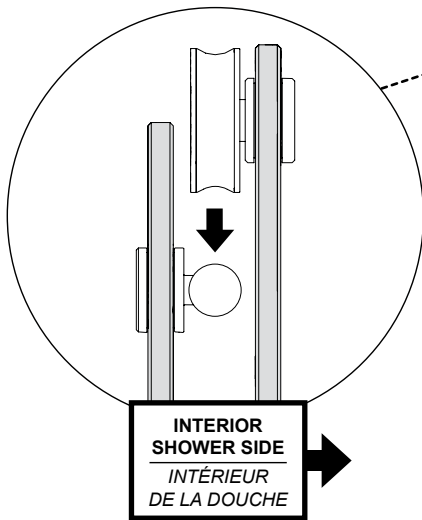

**ADJUST THE DOOR PANEL  
AJUSTER LE PANNEAU DE PORTE**



**ENSURE THAT THE SLIDING DOOR IS FLUSH AGAINST THE WALL. ADJUST THE ROLLER'S ECCENTRIC WASHER IF NECESSARY.**

*ASSURER QUE LE PANNEAU DE PORTE COULISSANTE EST D'APLOMB CONTRE LE MUR. AJUSTER LA RONDELLE EXCENTRIQUE DE LA ROULETTE SI NÉCESSAIRE.*

**A**

Door panel at its lowest position

Panneau de porte à la position la plus basse

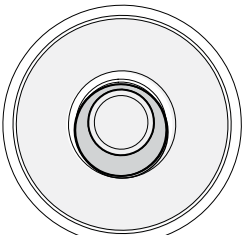

**B**

Door panel at its highest position

Panneau de porte à la position la plus haute

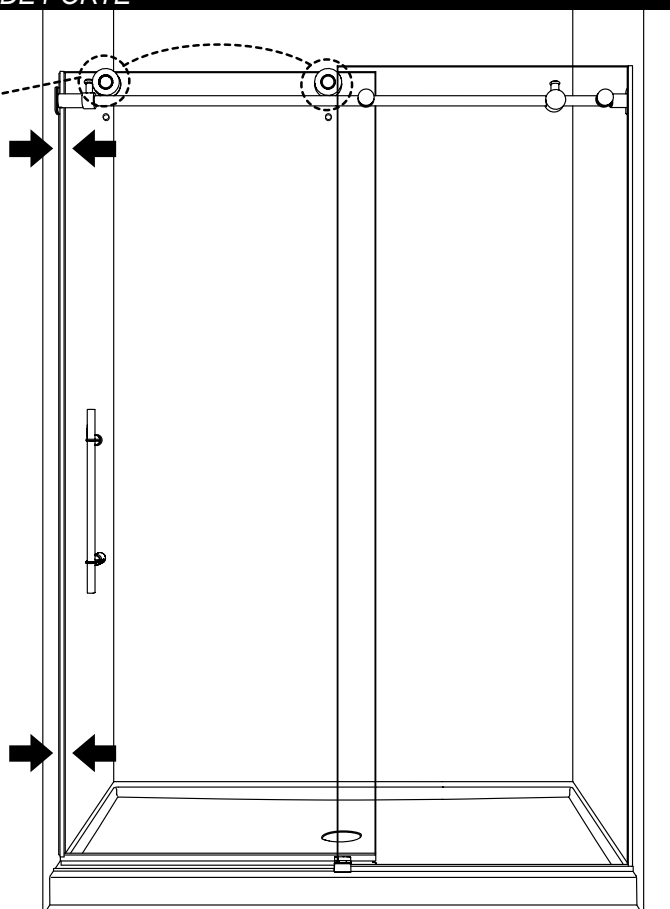
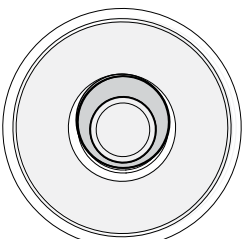

**INSTALL TWO ROLLERS ON THE DOOR PANEL  
INSTALLER DEUX ROULETTES SUR LE PANNEAU DE PORTE**

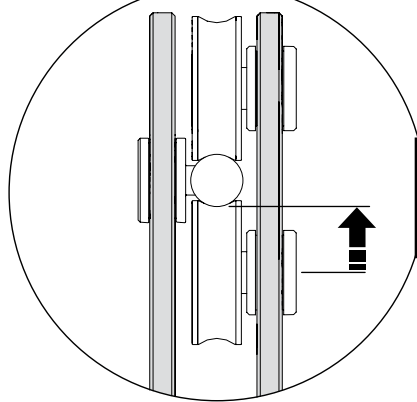
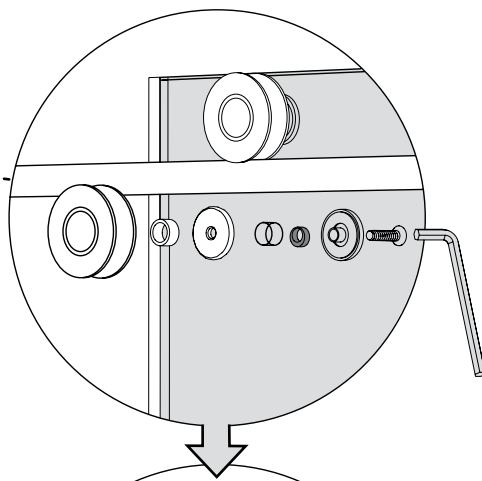
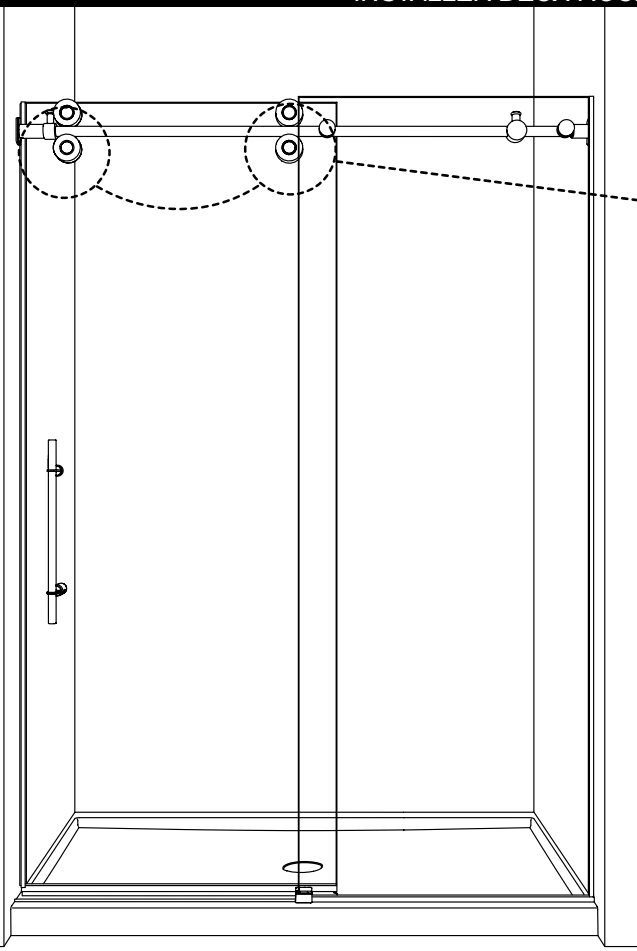

**INTERIOR  
SHOWER SIDE  
INTÉRIEUR  
DE LA DOUCHE**

**INSTALL THE CENTER GASKET ON THE DOOR PANEL**  
**INSTALLER LE JOINT DU CENTRE SUR LE PANNEAU DE PORTE**

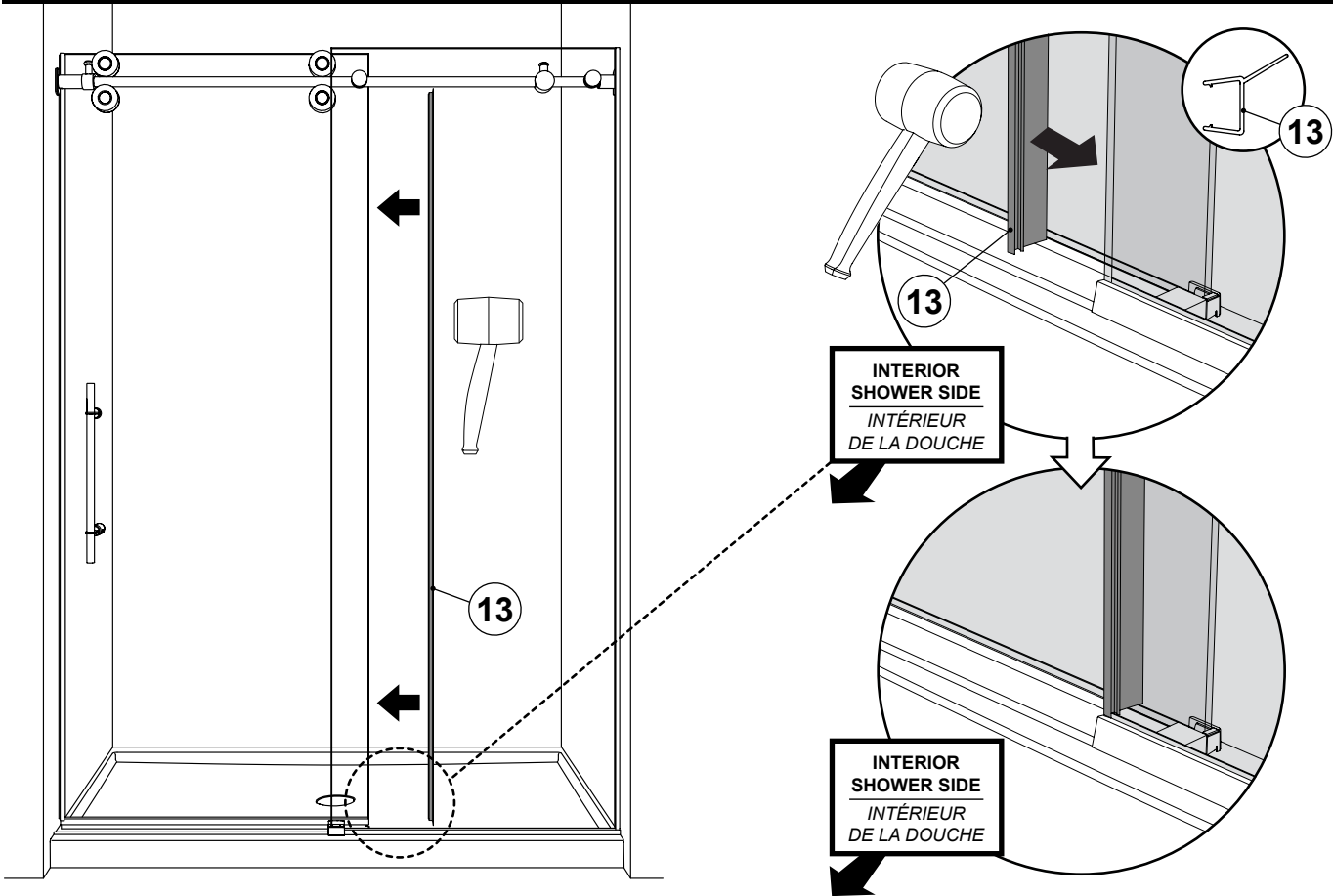

**POSITION THE STOPPERS**  
**POSITIONNER LES BUTOIRS**

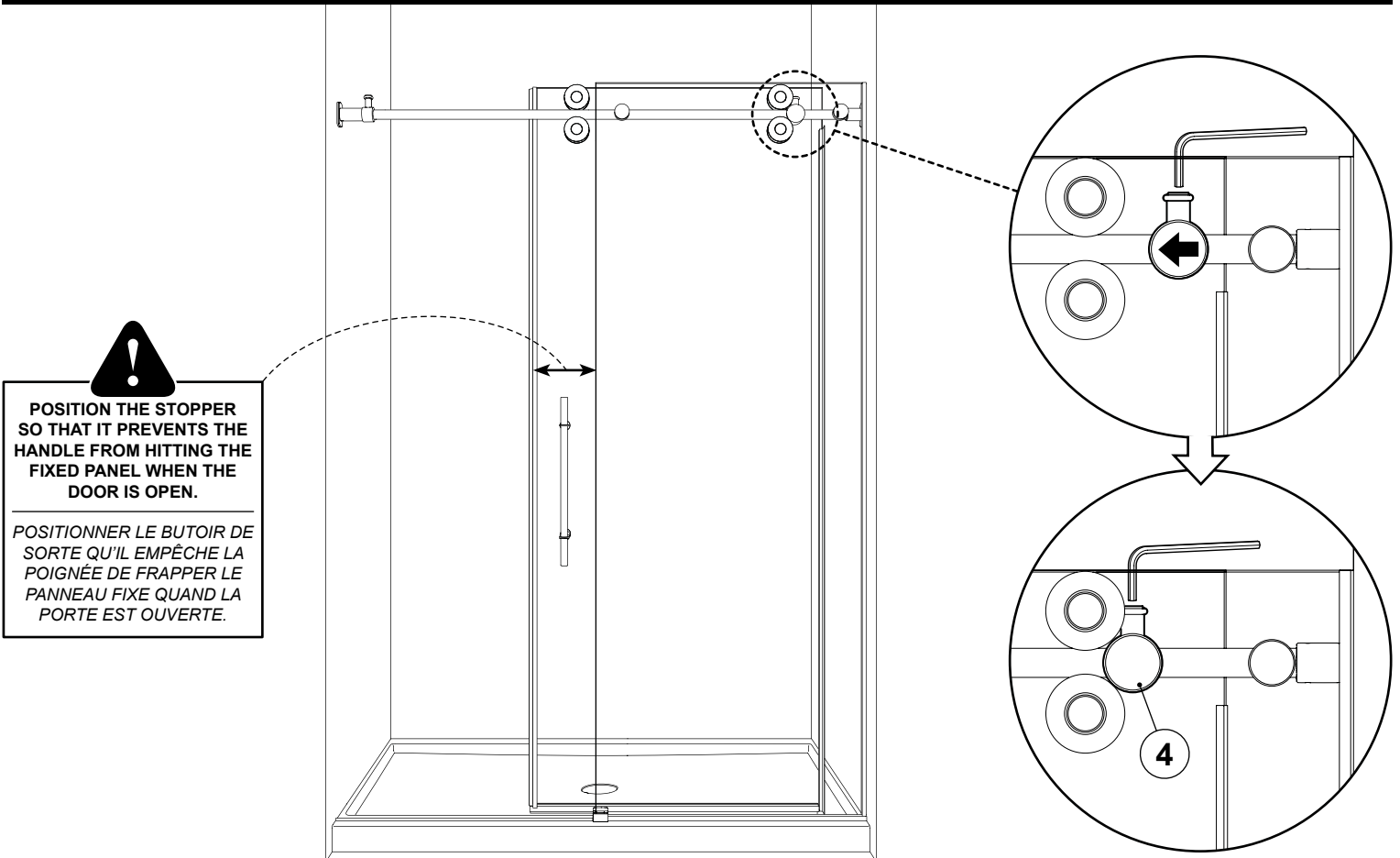

**CUT, SILICONE AND INSTALL THE THRESHOLD**  
**COUPER, MET DU SILICONE ET INSTALLER LE SEUIL**

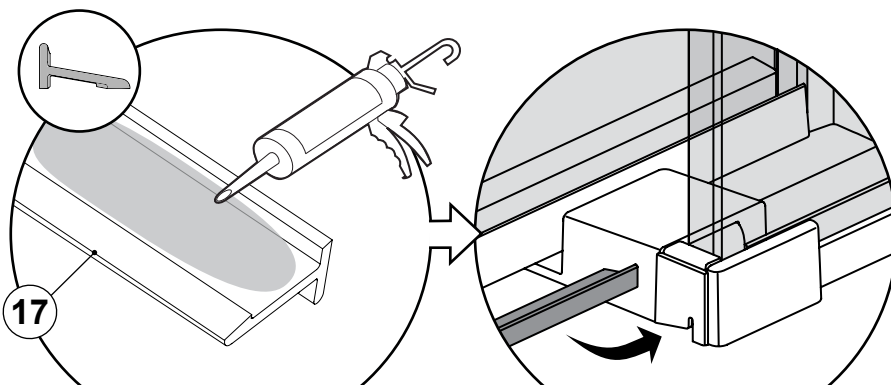
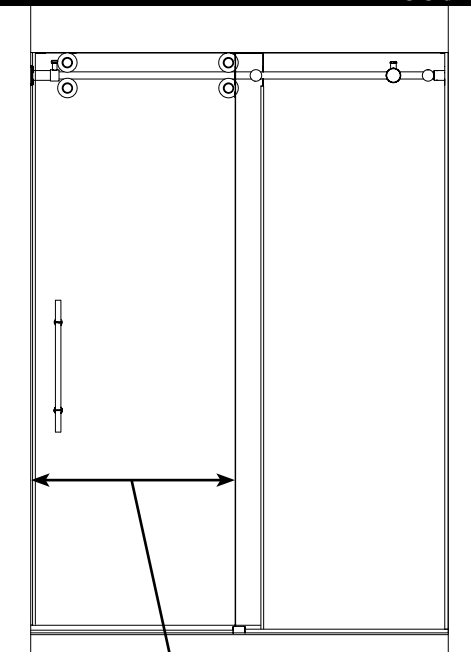

**WIPE THE BASE WITH A CLEAN CLOTH BEFORE INSTALLING THRESHOLD.**  
*ESSUYER LA BASE AVEC UN CHIFFON PROPRE AVANT D'INSTALLER LE SEUIL.*

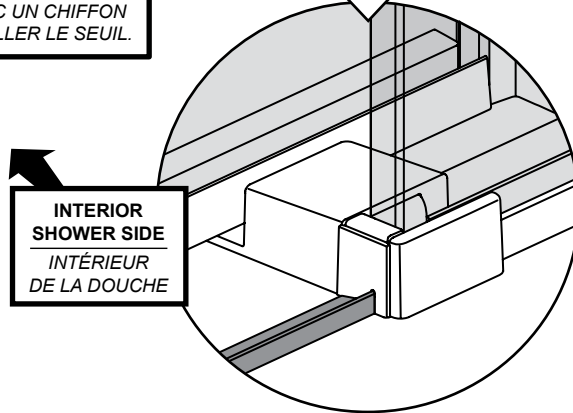

**INTERIOR SHOWER SIDE**  
**INTÉRIEUR DE LA DOUCHE**

**FORMULA / FORMULE**

**THRESHOLD = SUBTRACT 1/8" (3.2mm) FROM THE OPENING BETWEEN FINISHED WALL TO THE FIXED PANEL**

*THRESHOLD = SOUSTRAIRE 1/8" (3.2mm) DE L'OUVERTURE ENTRE MUR FINIS ET LE PANNEAU FIXE*

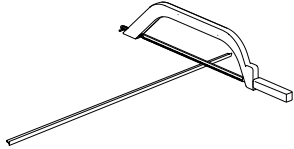

**SILICONE BACK OF THE THRESHOLD ANCHORS AND INSTALL**  
**CALFEUTRER L'ARRIÈRE LES ANCRAGES DE SEUIL ET INSTALLER**

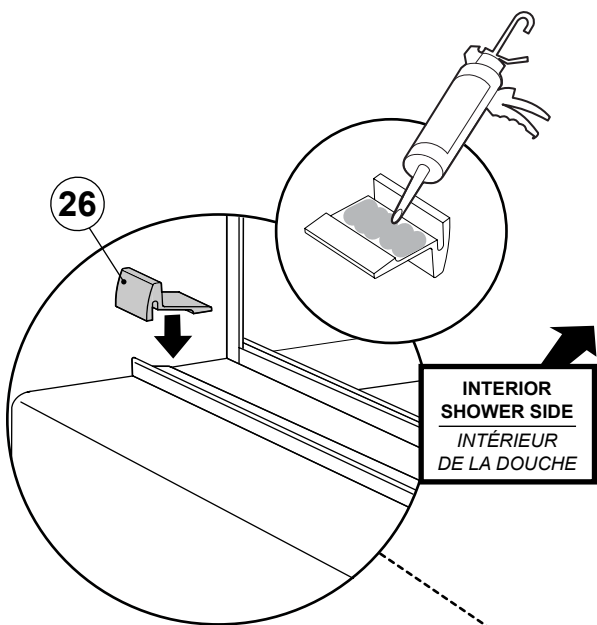

**INTERIOR SHOWER SIDE**  
**INTÉRIEUR DE LA DOUCHE**

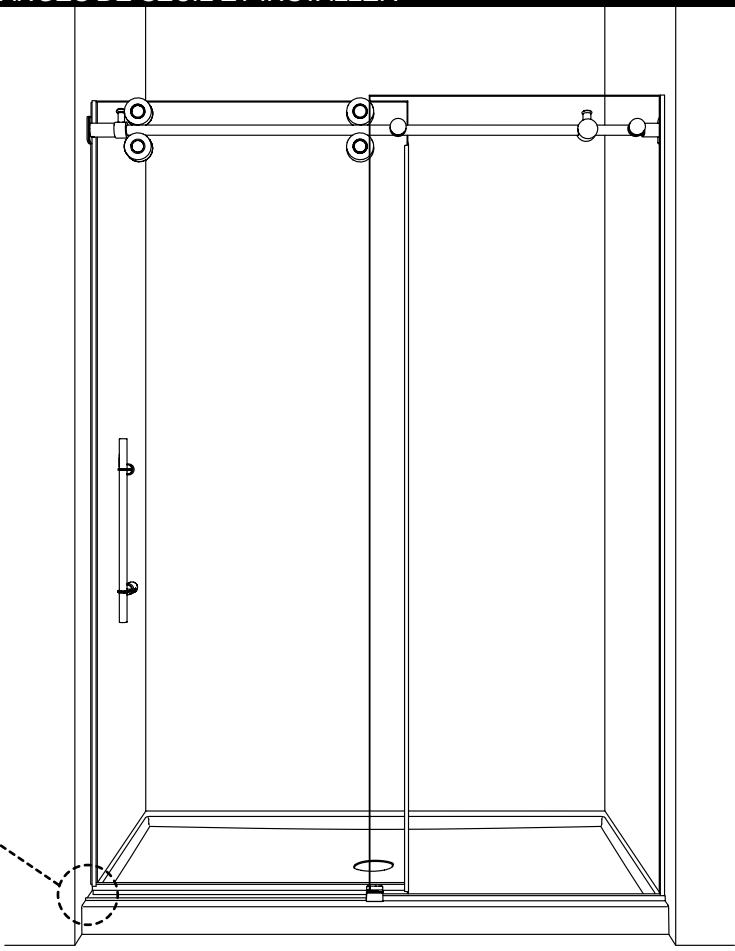

**SEAL THE SHOWER UNIT**  
**CALFEUTRER LA DOUCHE**

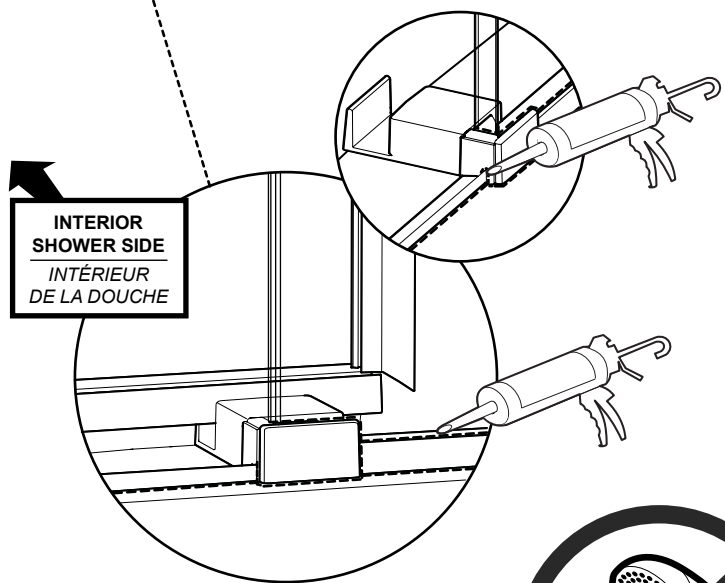
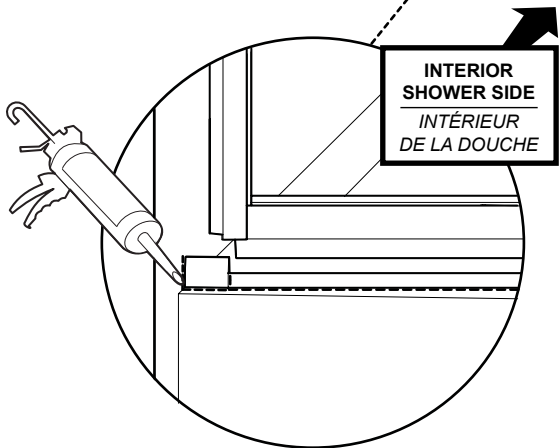
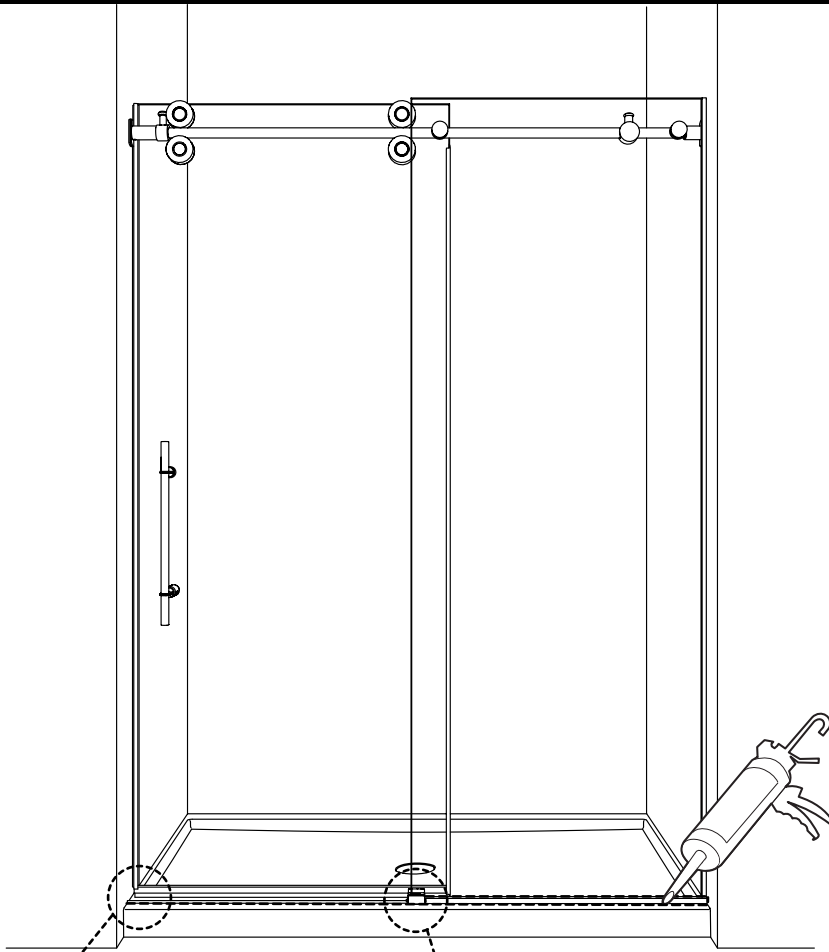

**24** HOURS  
HEURES