

Flex Damper – Ceiling Radiation Damper

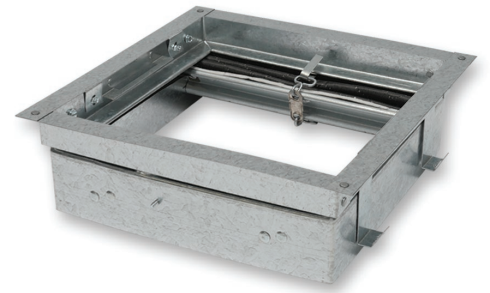

FlexDamper™

PC-RD05C5



- Folded ceramic curtain style damper to meet both Combustible and Non-Combustible UL Assemblies
- Allows for two-stage construction; fan housing and damper sleeve during framing, fan/motor/damper installation after finishes
- Easy access to fan/motor/damper for maintenance
- UL approved for most Panasonic 10 1/4" 50 – 150 CFM fans, fan/lights and fans with motion sensor
- Galvanized steel frame with 165°F fusible link
- High temperature, non-asbestos, reinforced fiber thermal fabric damper

ADDITIONAL BENEFITS

- Combustible Assemblies: UL 555C listed for use in a 1 hour fire-rated wood truss floor/ceiling and roof/ceiling designs.*
- Non-Combustible Assemblies: UL 555C listed for use in a 1, 2 or 3 hour fire rated floor/ceiling and roof/ceiling designs.**
- 5 year warranty

*UL 555C classification for the following 1 hour UL Wood Truss Assembly Ratings: L521, L528, L546, L558, L562, L574, L576, L581, L583, L585, M509; P522, P-533, P-538, P-545 and P-547.

**UL and Warnock Hersey 555C classification for 1, 2 or 3 hour Non-Combustible Assemblies.



File #: 3225-1598:100



All-in-one flexible radiation damper for combustible and non-combustible assemblies.

PC-RD05C5

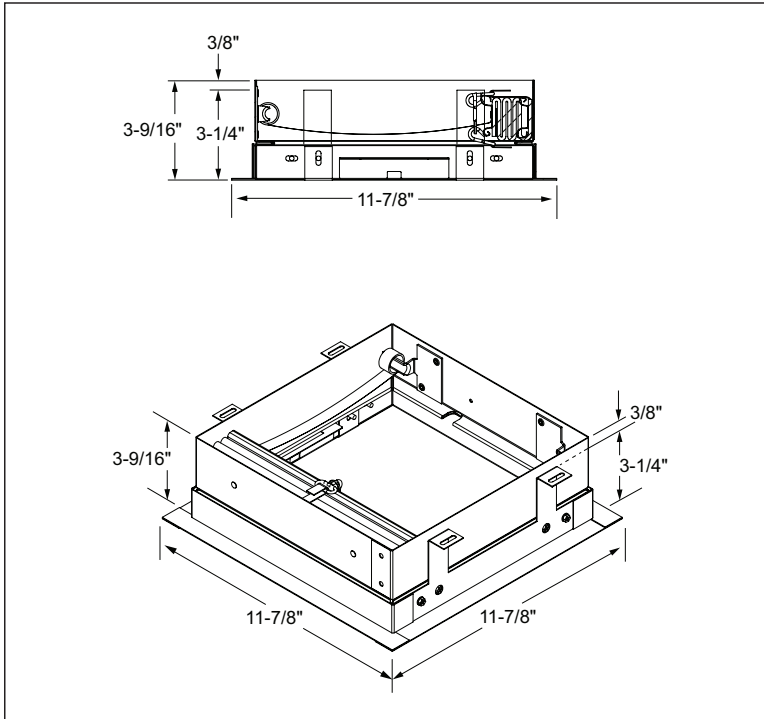

Integrated metal notch allows for easy installation of lights and motion sensors

Kit includes:

- Radiation damper
- Galvanized steel frame
- Mounting screws for frame to fan housing
- Clip and grommets to secure wire/pigtail
- Plaster guard
- Installation guide
- Warranty information

NON-COMBUSTIBLE ASSEMBLY

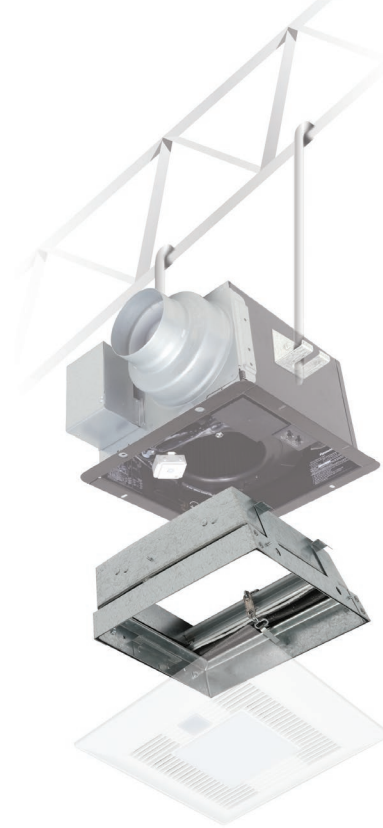

COMBUSTIBLE ASSEMBLY

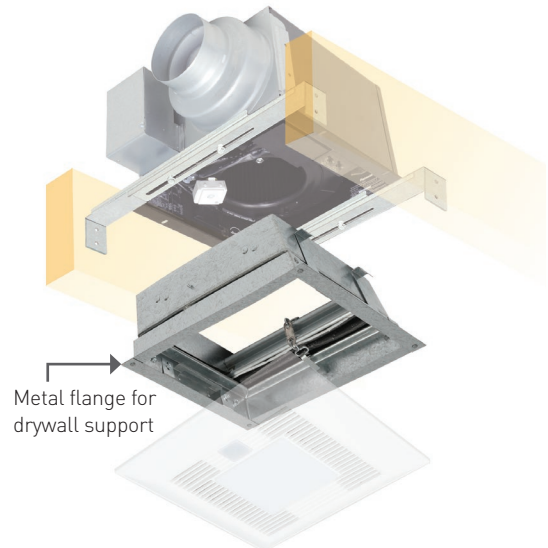

UL Approved for the Following Fan Models:	
Damper Model PC-RD05C5	WhisperGreen Select, WhisperCeiling DC, WhisperSense DC, WhisperFit DC, WhisperValue DC



Panasonic Life Solutions Company of America
IAQ Division
 Two Riverfront Plaza
 Newark, NJ 07102
us.panasonic.com/ventfans

For Order Information
 PHONE: 866-292-7299
 FAX: 888-553-0723
ventfans@us.panasonic.com