

PIA 3060 AFR

60 3/8" x 29 7/8" x 19 1/2"



PRODUCT DESCRIPTION:

With tiling flange 2 sides
R2R and L2L
Above-the-Floor Rough (AFR)
Adjustable feet
Contemporary style
Gloss finish resistant to stains and discoloration
Acrylic thermoformed and reinforced with fiberglass

10 days

WATER CAPACITY: 53 Imperial Gallons	IMMERSION: 12 1/4 po
BOX SIZE: 33 1/2 x 22 1/2 x 61	
NET WEIGHT: 85 lbs	GROSS WEIGHT: 100 lbs

GENERAL OPTIONS

Acrylic colors: white	Standard
Available in left or right version	
Drain D105 (20"): chrome finish	62.4020.102.60
Black neck pillow (12" x 4")	18.6000.100.20

ACTIV-AIR OPTIONS

Finish for Activ-Air jets: white	Standard
Other: chrome	
Blower hose extension 72"	95.5013.167.00
Blower hose extension 96"	95.5013.168.00

Blower extensions are necessary when the blower is located more than 4' from the pneumatic control.

* Customized product, non cancellable, non returnable.

* All systems and options automatically come in the same colour as the bathtub unless otherwise specified on the purchase order.

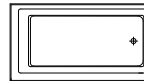

Bathtub only left drain
Bathtub only right drain

E10.20710.5700
E10.20710.5200

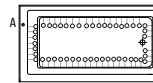

Activ-Air left drain
Activ-Air right drain

E15.20710.570010
E15.20710.520010

Included: 32 Activ-Air micro-jets,
one blower with heating element (200 W)
and one pneumatic control.

—○ : Activ-Air jets

A : Activ-Air control

Note : The blower is never installed.



Intertek



Certification ECORESPONSIBLE
First manufacturer of bathroom products in
North America to be certified ecoresponsible.



Produits Neptune

ENTREPRENEUR

6835, Picard street, Saint-Hyacinthe (Quebec) J2S 1H3
Phone: (450) 773-7058 - produitsneptune.com

REV: 08-21



Produits Neptune

ENTREPRENEUR

PIA 3060 R2R AFR

Bathtub

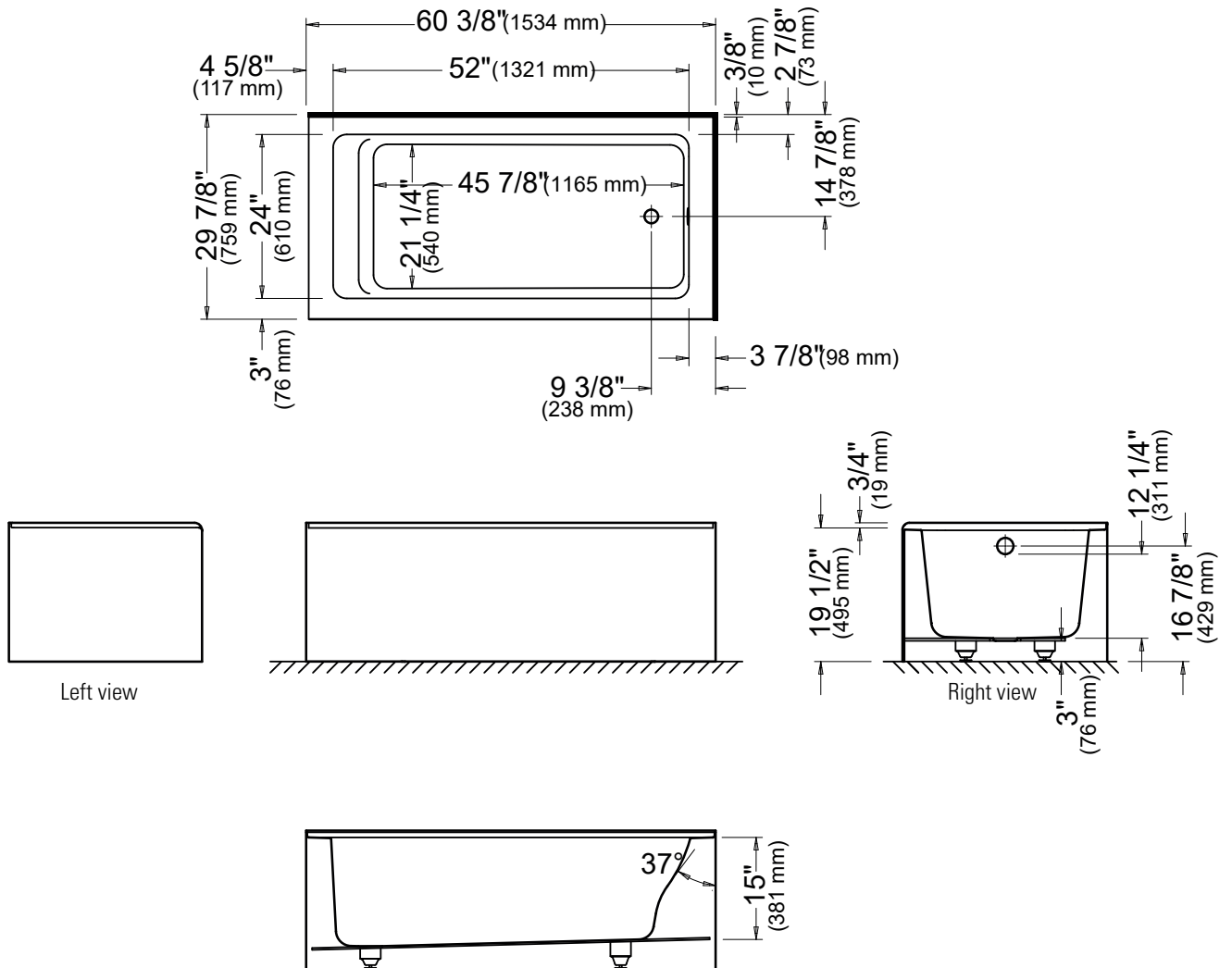

*All dimensions are approximate and subject to change without notice.
Please refer to the installation guide before beginning the installation



Produits Neptune

ENTREPRENEUR

PIA 3060 L2L AFR

Bathtub

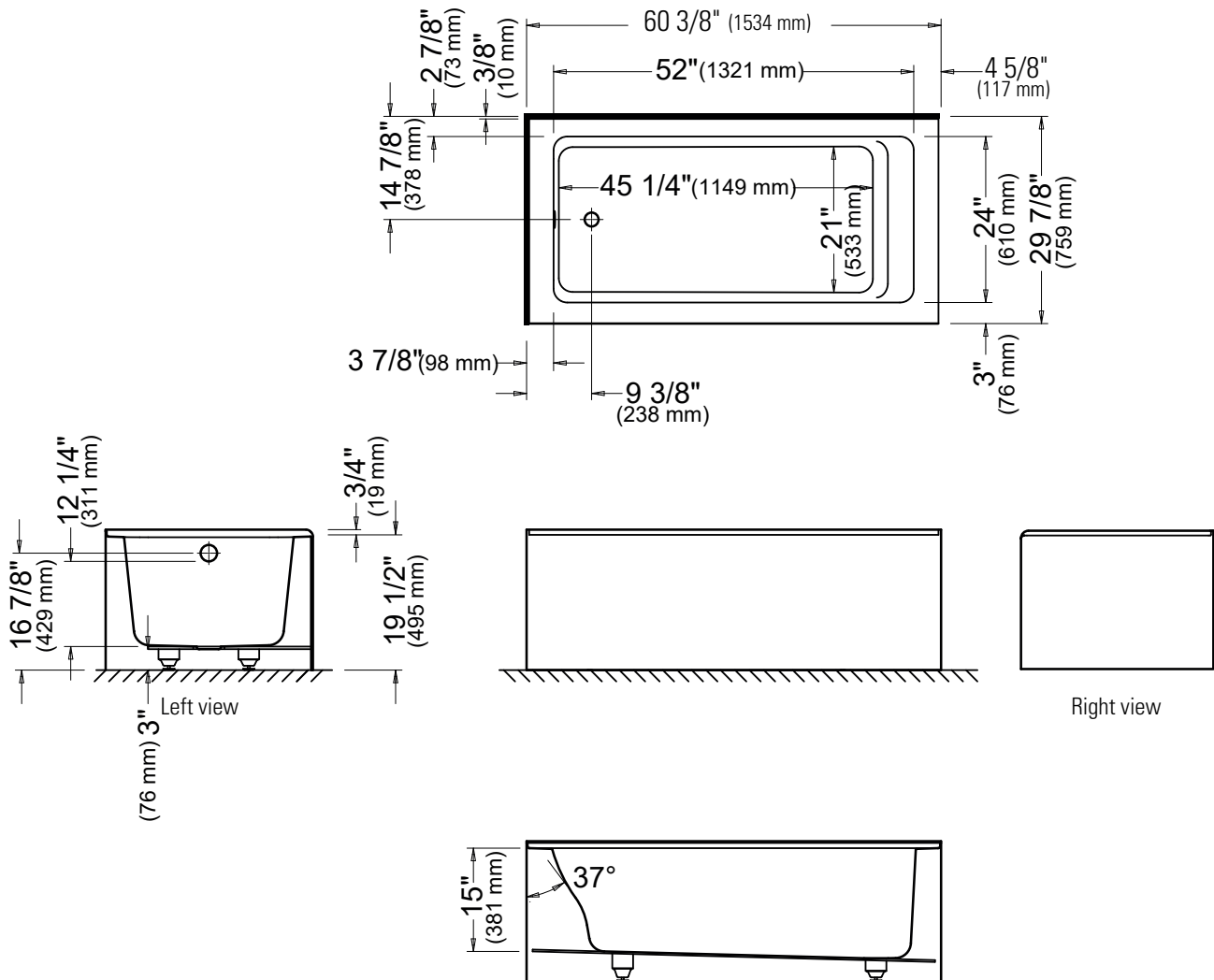

*All dimensions are approximate and subject to change without notice.
Please refer to the installation guide before beginning the installation

PIA 3060 AFR

60 3/8" x 29 7/8" x 19 1/2"



PRODUCT DESCRIPTION:

With tiling flange 2 sides
 R2L and L2R
 Above-the-Floor Rough (AFR)
 Adjustable feet
 Contemporary style
 Gloss finish resistant to stains and discoloration
 Acrylic thermoformed and reinforced with fiberglass

10 days

WATER CAPACITY: 53 Imperial Gallons	IMMERSION: 12 1/4 po
BOX SIZE: 33 1/2 x 22 1/2 x 61	
NET WEIGHT: 85 lbs	GROSS WEIGHT: 100 lbs

GENERAL OPTIONS

Acrylic colors: white	Standard
Available in left or right version	
Drain D105 (20"): chrome finish	62.4020.102.60
Black neck pillow (12" x 4")	18.6000.100.20

ACTIV-AIR OPTIONS

Finish for Activ-Air jets: white	Standard
Other: chrome	
Blower hose extension 72"	95.5013.167.00
Blower hose extension 96"	95.5013.168.00

Blower extensions are necessary when the blower is located more than 4' from the pneumatic control.

* Customized product, non cancellable, non returnable.

* All systems and options automatically come in the same colour as the bathtub unless otherwise specified on the purchase order.

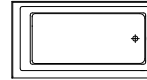

Bathtub only left drain
Bathtub only right drain

E10.20710.5800
 E10.20710.5300

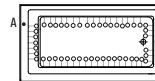

Activ-Air left drain
Activ-Air right drain

E15.20710.580010
 E15.20710.530010

Included: 32 Activ-Air micro-jets,
 one blower with heating element (200 W)
 and one pneumatic control.

—○ : Activ-Air jets

A : Activ-Air control

Note : The blower is never installed.



Intertek



Certification ECORESPONSIBLE
 First manufacturer of bathroom products in
 North America to be certified ecoresponsible.



Produits Neptune

ENTREPRENEUR

6835, Picard street, Saint-Hyacinthe (Quebec) J2S 1H3
 Phone: (450) 773-7058 - produitsneptune.com

REV: 08-21



Produits Neptune

ENTREPRENEUR

PIA 3060 R2L AFR

Bathtub

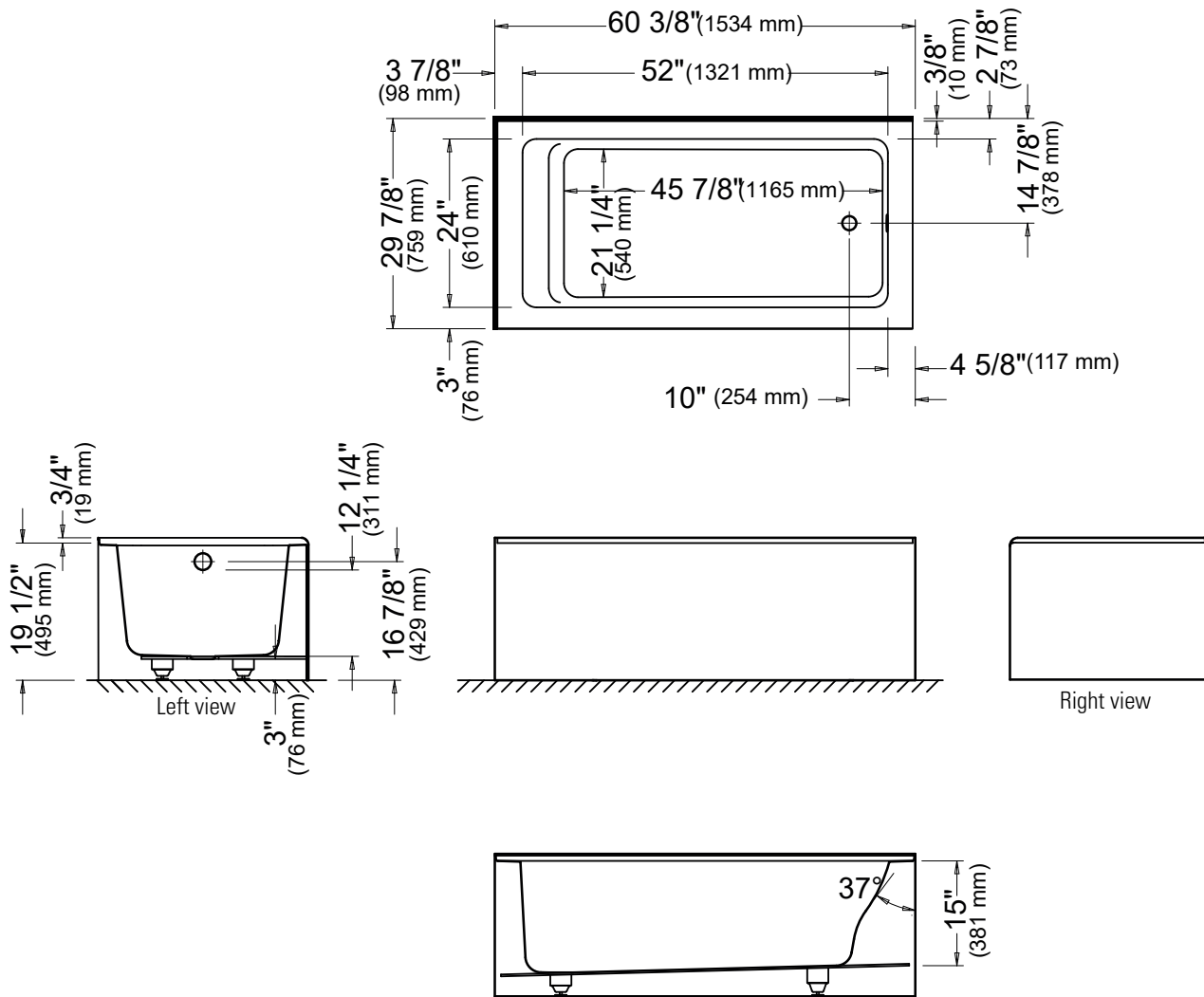

*All dimensions are approximate and subject to change without notice.
Please refer to the installation guide before beginning the installation



Produits Neptune
ENTREPRENEUR

PIA 3060 L2R AFR Bathtub

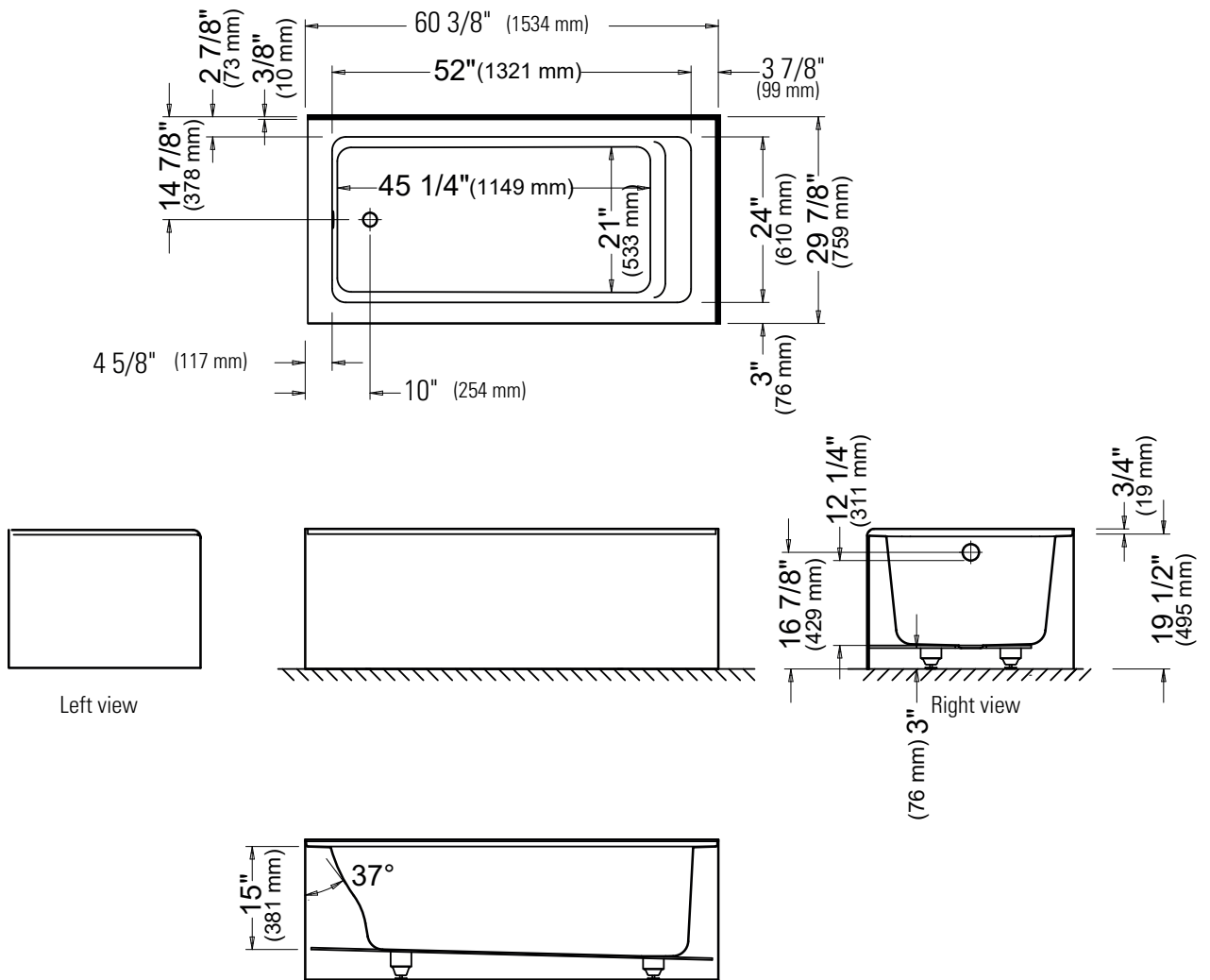

*All dimensions are approximate and subject to change without notice.
Please refer to the installation guide before beginning the installation