

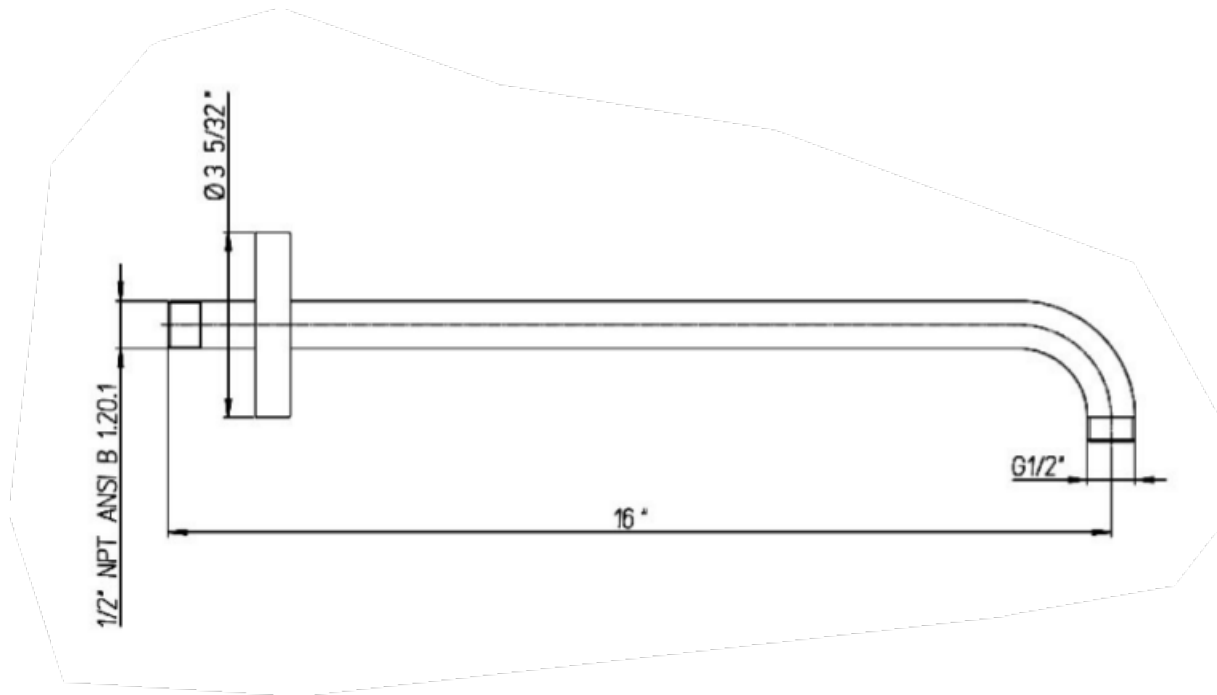

LATOSCANA
by Pavi

50-74516



16" Wall Mount Shower Arm



Bath/Various

50-74516

16" Wall Mount Shower Arm

STANDARDS

- Compliant with ASME A112.18.1-B125.1
- Compliant with AB1953
- Compliant with ANSI NSF61 – Annex G
- Certified by CSA International
- Compliant with ANSI A117.1

Finishes

	50CR74516	50PW74516	50OK74516
Polished Chrome	X		
Brushed Nickel		X	
Matt Gold			X

Features

	50CR74516	50PW74516	50OK74516
Solid Brass Construction	X	X	X
Meets NSF 61/9 Annex G Lead Requirements	X	X	X
ADA Compliant	X	X	X
Step-By-Step Installation Instructions	X	X	X
Limited Lifetime Warranty	X	X	X

1-866-668-6690
 1571 MAIN RD
 NEWFIELD, NJ 08344

www.paini-usa.com