

THANK YOU FOR CHOOSING RYVYR

Please take a few minutes to review this manual before you start installation. If you encounter any installation problems, please don't hesitate to contact us. Before you begin, please observe all local building codes. Unpack the new product and inspect for damage. The appearance of your vanity may differ from the illustrations in this guide. These instructions still apply. Please ensure the finished wall is straight and plumb and the floor is flat and perpendicular to the finished wall.

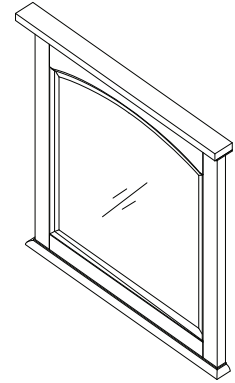

SUGGESTED TOOLS AND MATERIALS



Phillips Screwdriver



Level



Drill



Tape Measure

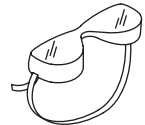

Safety Glasses

MIRROR INSTALLATION

1

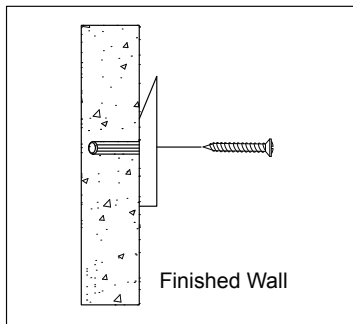
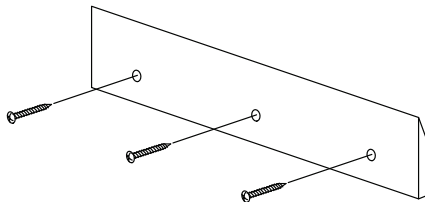

2

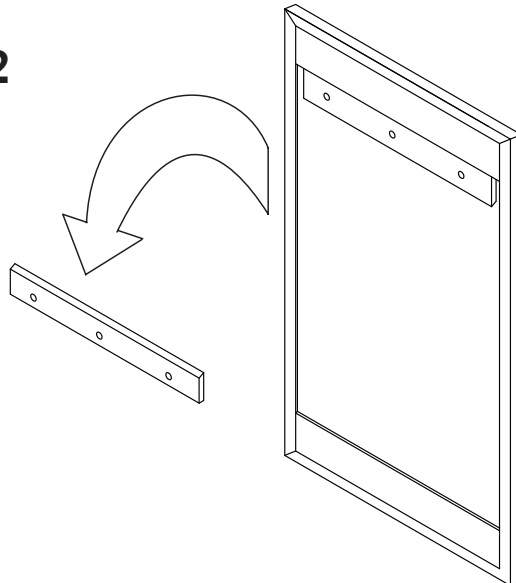

NOTE: Where possible, try to affix a stud or provide adequate wall support for the size and weight of the mirror. Mirror comes with pre-attached brackets on the frame and a wall mount rail. Affix the rail to the wall in the desired location by pre-drilling the rail and then affixing the rail using the proper fastening, based upon wall material.

CARE AND CLEANING

- To maintain the beauty of the finish, avoid placing the furniture in direct sunlight, as sunlight causes fading. Also avoid extreme changes in temperature by arranging furniture away from radiators, heat and air vents, and air conditioning units. Avoid placing furniture directly under windows. Damage caused by any of the afore mentioned will void the warranty.
- Clean the mirror using a soft, slightly damp cloth or a soft cloth with glass cleaner. Avoid using silicone cleaners and waxes.
- Clean the furniture frequently with a clean, soft, dry, lint-free cloth. Clean the surface by gently rubbing in the direction of the grain. Avoid using silicone cleaners and waxes.
- Clean up excess water and spills immediately. Use blotting rather than a wiping action. Water left over a long period of time will cause white spots in the finish and the furniture to possibly warp. Please note that some chemicals may damage the finish. Standing water and the use of strong chemicals will void the warranty.