

- DE** Diese Anleitung muss dem Benutzer ausgehändigt werden. Garantie/Haftung nur bei Montage gemäß Anleitung durch eine konzessionierte Fachkraft und gemäß örtlicher Vorschriften.
- FR** Cette instruction doit être remise à l'utilisateur. Garantie/responsabilité uniquement assurées en cas de montage conforme au mode d'emploi, effectué par un spécialiste concessionnaire et en fonction des prescriptions locales.
- IT** Le presenti istruzioni devono essere consegnate all'utilizzatore. Garanzia/responsabilità assicurate soltanto in caso di montaggio conforme alle istruzioni per l'uso e eseguito da uno specialista concessionario in funzione delle prescrizioni locali.
- EN** This instruction must be given to the user. Guarantee/Liability only when assembled by an approved specialist in accordance with the instructions and local regulations.
- ES** Se entregará este manual de instrucciones al usuario. Garantía/Responsabilidad sólo cuando está montado según las instrucciones de un profesional autorizado y de conformidad con la normativa local.
- NL** Deze handleiding moet aan de gebruiker worden bezorgd. Garantie/aansprakelijkheid enkel bij montage volgens de handleiding door een bevoegde vakman en volgens de lokale voorschriften.
- CS** Tento návod musí být předán uživateli. Garance/záruka pouze při montáži, prováděné dle návodu osobou odborně způsobilou s příslušnou koncesí a dle předpisů platných v místě.
- LT** Ši instrukcija turi būti perduota naudotojui. Garantija/turtinė atsakomybė suteikiama, jei montavimą pagal instrukciją atlieka kvalifikuotas specialistas pagal vietinius reikalavimus.
- PL** Niniejsza instrukcja obsługi powinna zostać przekazana użytkownikowi. Gwarancja/odpowiedzialność prawna działa wyłącznie w przypadku montażu wykonanego przez upoważnionego specjalistę zgodnie z instrukcją oraz lokalnymi przepisami.
- HU** Jelen útmutató a felhasználó rendelkezésére kell bocsátani. Garancia/felelősség csak engedéllyel rendelkező szakember által végrehajtott, az útmutatásnak és a helyi előírásoknak megfelelő szerelés esetén.
- RU** Данное руководство должно быть передано пользователю. Гарантия действительна только в том случае, если монтаж выполнен специалистом согласно инструкции и с учетом местных предписаний.
- BG** Това ръководство трябва да бъде връчено на потребителя. Гаранция / отговорност само при монтаж в съответствие с ръководството от лицензиран специалист и в съответствие с действащо законодателство.
- DA** Denne vejledning skal udleveres til brugeren. Garanti/ansvar gælder kun, hvis monteringen er foretaget af en autoriseret fagmand i overens stemmelse med brugsvejledningen og de lokale regler.
- SV** Denne veiledningen må utleveres til brukeren. Garantien gjelder kun når enheten er montert av en godkjent spesialist i henhold til instruksjo nene og lokale forskrifter.
- NO** Takuu ja vastuuvollisuus ovat voimassa vain, kun laitteen kokoa valtuutettu asiantuntija ohjeiden ja paikallisten määräysten mukaisesti.
- FI** Denna anvisning måste överlämnas till användaren. Tämä ohje täytyy antaa käyttäjälle. Garanti/ansvar gäller bara då en godkänd specialist utfört monteringen i enlighet med instrukti onerna och lokala bestämmelser.
- SK** Tento návod musí byť doručený používateľovi. Záruka platí, len ak sa montáž vykoná podľa návodu a ak ju vykoná odborník s oprávnením a v súlade s miestnymi predpismi.
- ZH** 必须将本说明书当面交给用户。保修/责任仅在遵照说明书，并由授权的专业人员符合当地法规安装时有效。
- ET** See juhend tuleb kasutajale anda. Garantii / vastutus kehtib ainult paigaldusloaga spetsialisti tehtud juhendile vastava paigalduse korral ja kohalike eeskirjade järgi.
- HR** Ove se upute moraju predati korisniku. Jamstvo vrijedi samo ako je montažu izvršilo ovlašteno stručno osoblje prema uputama i lokalnim propisima.
- LV** Šīs instrukcijas ir jānodod lietotājam. Garantija ir spēkā tikai tad, ja uzstādīšanu veic licencēts speciālists saskaņā ar instrukcijām un atbilstoši vietējiem noteikumiem.
- PT** O presente manual deve ser entregue ao utilizador. A garantia só é válida se a instalação for realizada por um técnico autorizado, de acordo com as instruções e os regulamentos locais.
- RO** Prezentele instrucțiuni trebuie înmânate utilizatorului. Garanția este valabilă doar în cazul montării conforme cu instrucțiunile de către un specialist concesionat și respectând prevederile locale.
- TR** Bu talimat, kullanıcuya teslim edilmelidir. Garanti / sorumluluk, ürün sadece kilavuzda öngörülen şekilde yetkili uzman personel tarafından ve yerel yönetmeliklerde öngörülmediği şekilde monte edilmediğinde geçerlilik kazanır.
- SR** Ova uputstva moraju se predati korisniku. Garancija / odgovornost samo ako ih montira ovlašćeno lice u skladu sa uputstvima i lokalnim propisima.
- SL** Ta navodila je treba izročiti uporabniku. Garancija / odgovornost velja samo v kolikor montirano s strani stokovnega osebjja, v kolikor v skladu z navodili za montažo, v kolikor so upoštevani lokalni veljavni predpisi.

# ALESSI | LAUFEN

H811971

- DE** Stand-Waschtisch  
**FR** Lavabo au sol  
**IT** Lavabo a totem  
**EN** Floorstanding washbasin  
**ES** Lavabo exento  
**NL** Vloerstaande wastafel  
**CS** Stojící umývadlo  
**LT** Laisvai pastatomi praustuvi  
**PL** Umywalka wolnostojąca  
**HU** Padlón álló mosdó  
**RU** Свободностоящая раковина  
**BG** Стоящ умивалник  
**DA** Gulvstående håndvask  
**SV** Golv tvättställ  
**NO** Frittstående servant  
**FI** Jalusta pesuallas  
**SK** Stojace umývadlo  
**ZH** 独立式洗面盆  
**ET** Pjedestaal Kraanikauss  
**HR** Stojeci umivaonik  
**LV** Pjedaštāla izlietne  
**PT** Lavatório de coluna  
**RO** Lavoar pe pardoseala  
**TR** Bağımsız lavabo  
**SR** Samostojeći umivaonik  
**SL** Prostostoječi umivalnik



Lieferumfang  
 Contenu du colis  
 Distinta dei pezzi  
 Parts list  
 Alcance del suministro

Toebehoren  
 Rozsah dodávky  
 Dalių sąrašas  
 Zakres dostawy  
 Szállítási terjedelem

Комплекция  
 Списък на детайлите  
 Leveringsomfang  
 Leveransomfattning  
 Leveranseomfang

Toimituskokonaisuus  
 Obsah dodávky  
 供货范围  
 Osade nimekiri  
 Popis dijelova

Dalu saraksts  
 Lista de peças  
 Volumul livrării  
 Parça listesi  
 Lista delova

Seznam delov

H811971xxx1091\_GLOBAL excl. USA\_CAN

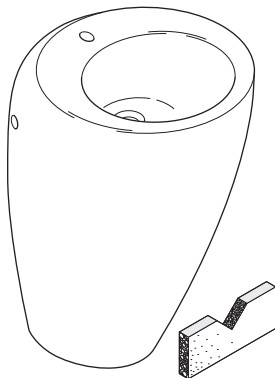

H898184

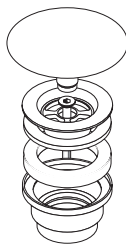

H891757

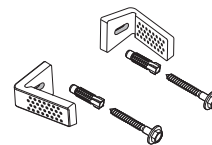

Dimensionen	Afmetingen	Размеры	Suora	Izmēri	Dimenzije
Dimensions	Rozměry	Размери	Rozmery	Dimensões	
Dimensioni	Matmenys	Пакалве	规格	Masă	
Dimensions	Wymiary	Şapa	Mõõtmed	Boyutlar	
Dimensiones	Méreték	Grønnsápe	Dimenzije	Dimenzije	

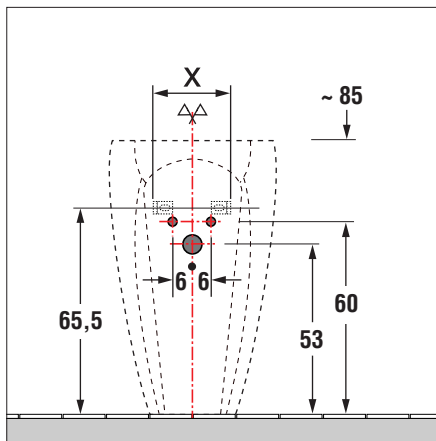

Montageablauf  
Exécution du montage  
Esecuzione del montaggio  
Assembly procedure  
Proceso de montaje

Montageverloop  
Průběh montáže  
Montavimo tvarka  
Odplyw montażowy  
A szerelés menete

Последовательность монтажа  
Протичане на монтажа  
Monteringsstrin  
Monteringsprocedur  
Monteringsbeskrivelse

Asennuksen  
Montáž  
装配程序  
Kokkumonteerimine  
Postupak montaže

Montāžas procedūra  
Proceso de montagem  
Desfășurarea montajului  
Montaj prosedürü  
Uputstvo za montažu  
Navodila za montažo

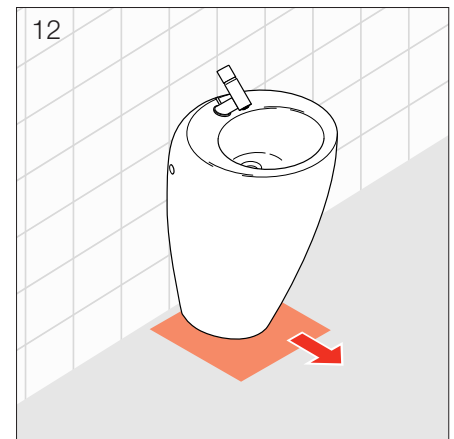
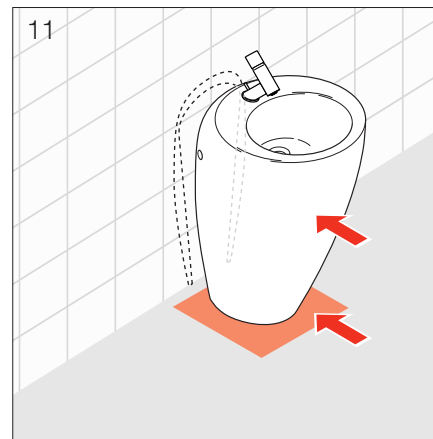
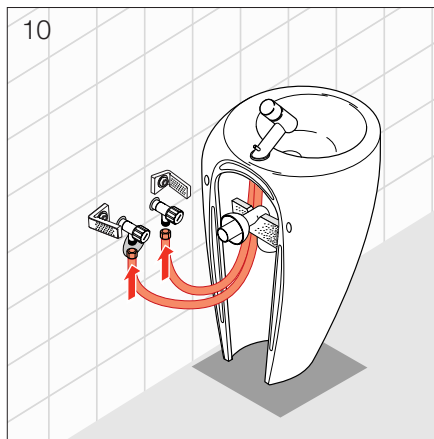
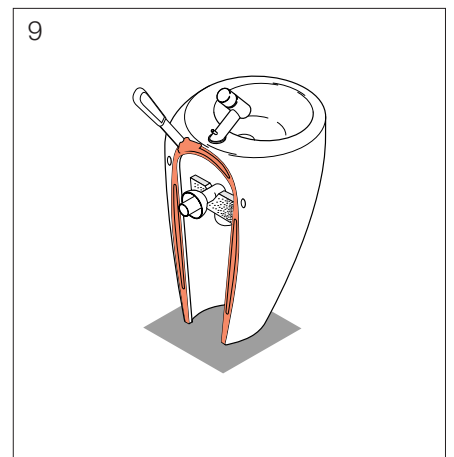
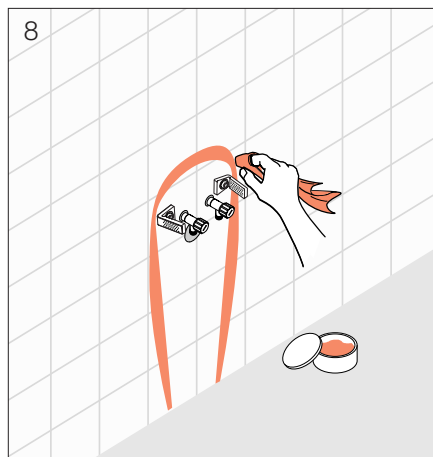
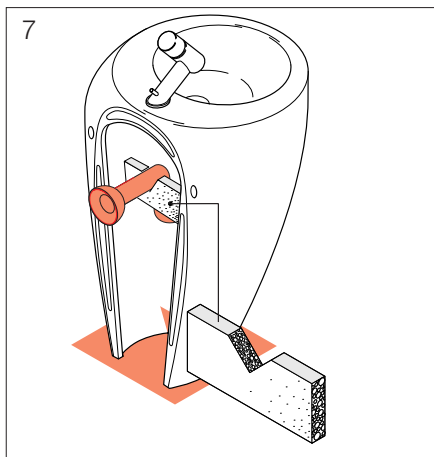
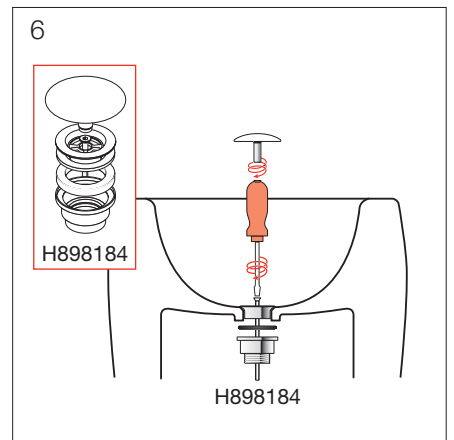
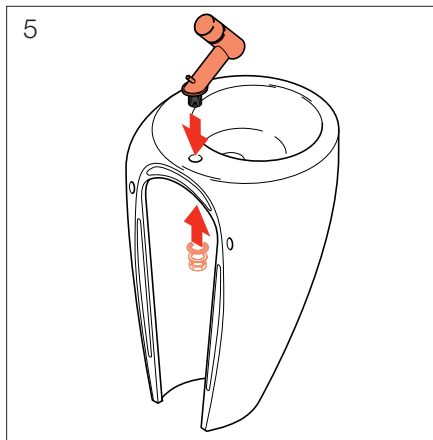
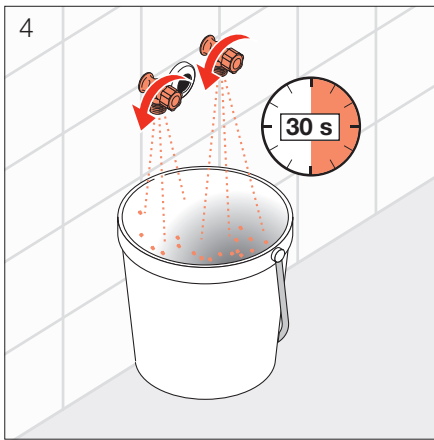
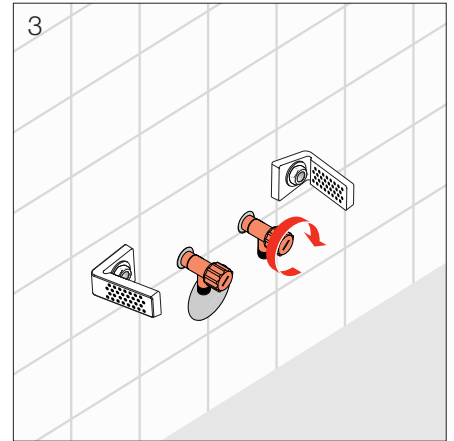
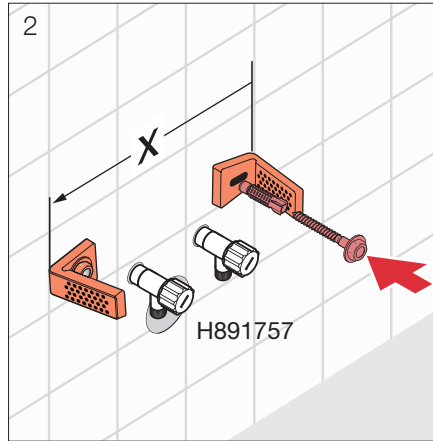
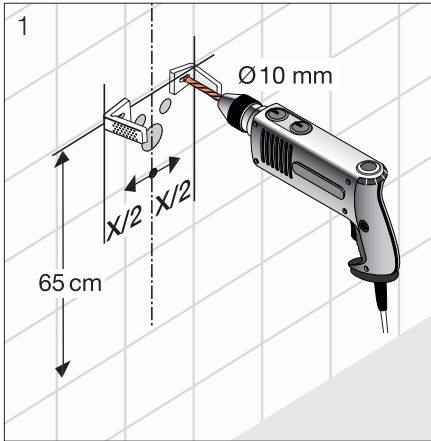

Montageablauf  
Exécution du montage  
Esecuzione del montaggio  
Assembly procedure  
Proceso de montaje

Montageverloop  
Průběh montáže  
Montavimo tvarka  
Odplyw montażowy  
A szerelés menete

Последовательность монтажа  
Протичане на монтажа  
Monteringsstrin  
Monteringsprocedur  
Monteringsbeskrivelse

Asennuksen  
Montáž  
装配程序  
Kokkumonteerimine  
Postupak montaže

Montāžas procedūra  
Proceso de montagem  
Desfășurarea montajului  
Montaj prosedürü  
Uputstvo za montažu  
Navodila za montažo

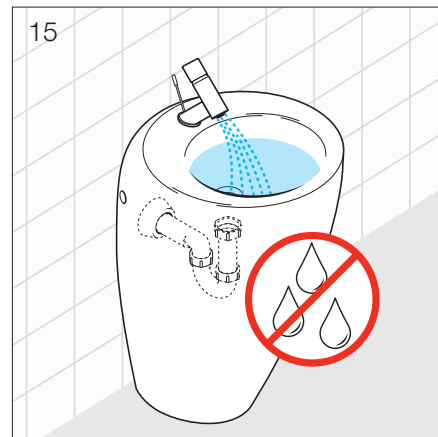
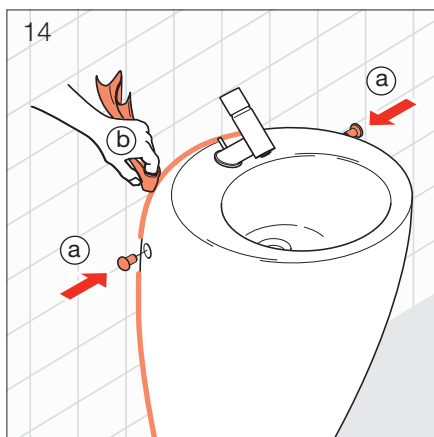
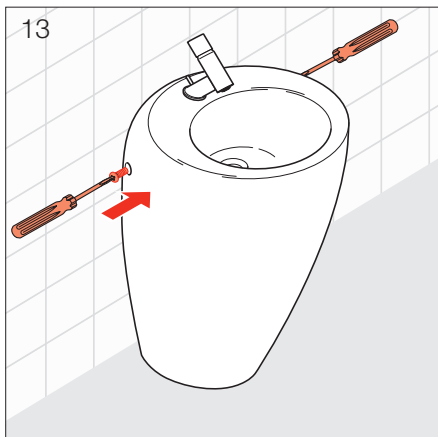

Lieferumfang  
Contenu du colis  
Distinta dei pezzi  
Parts list  
Alcance del suministro

Toebehoren  
Rozsah dodávky  
Dalių sąrašas  
Zakres dostawy  
Szállítási terjedelem

Комплектация  
Списък на детайлите  
Leveringsomfang  
Leveransomfattning  
Leveranseomfang

Toimituskokonaisuus  
Obsah dodávky  
Dalių sąrašas  
Osade nimekiri  
Popis dijelova

Dalu saraksts  
Lista de peças  
Volumul livrării  
Parça listesi  
Lista delova

Seznam delov

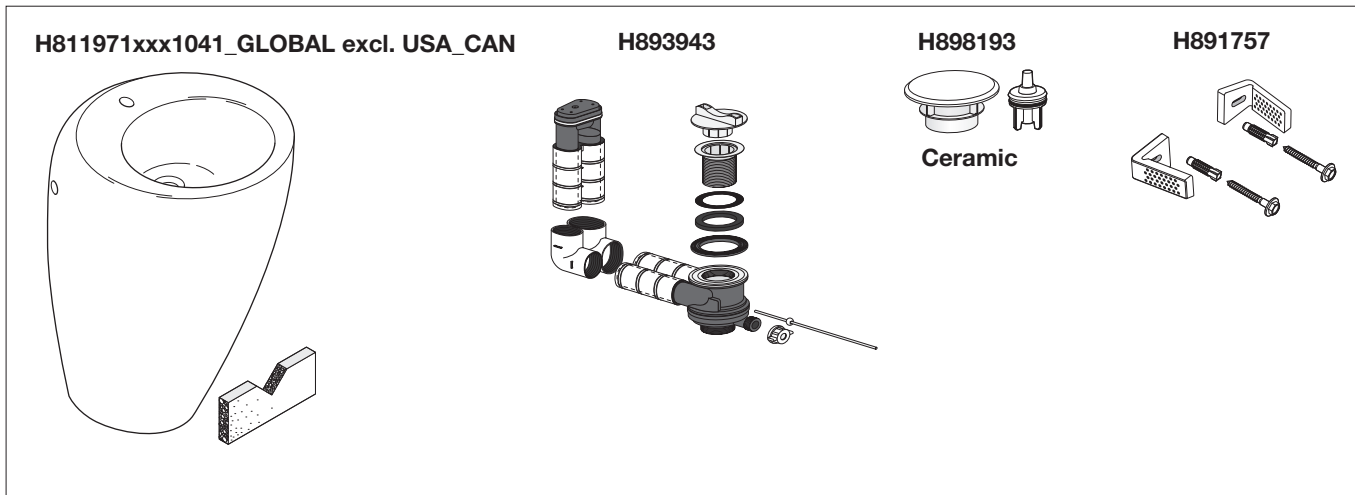

Dimensionen	Afmetingen	Размеры	Suora	Izmēri	Dimenzije
Dimensions	Rozměry	Размери	Rozmery	Dimensões	
Dimensioni	Matmenys	Пакалве	规格	Masă	
Dimensions	Wymiary	Сăпа	Мôötмед	Boyutlar	
Dimensiones	Méreték	Grønnsăpe	Dimenzije	Dimenzije	

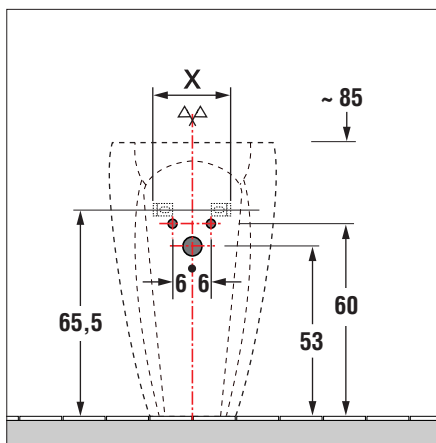

Montageablauf  
Exécution du montage  
Esecuzione del montaggio  
Assembly procedure  
Proceso de montaje

Montageverloop  
Průběh montáže  
Montavimo tvarka  
Odplyw montażowy  
A szerelés menete

Последовательность монтажа  
Протичане на монтажа  
Monteringstrin  
Monteringsprocedur  
Monteringsbeskrivelse

Asennuksen  
Montáž  
装配程序  
Kokkumonteerimine  
Postupak montaže

Montāžas procedūra  
Proceso de montagem  
Desfășurarea montajului  
Montaj prosedürü  
Uputstvo za montažu  
Navodila za montažo

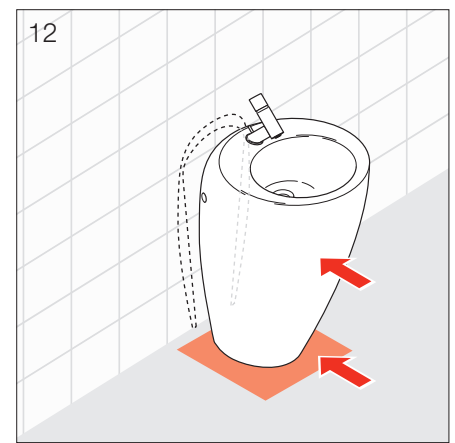
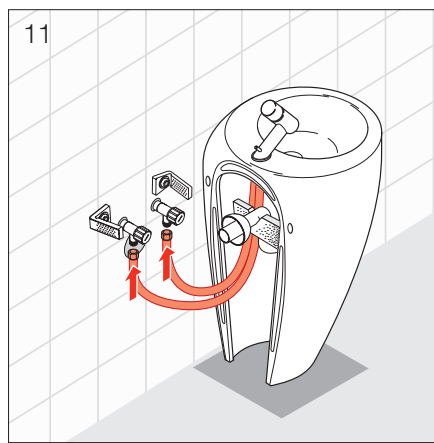
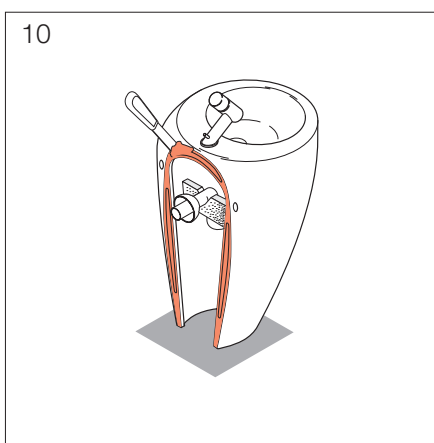
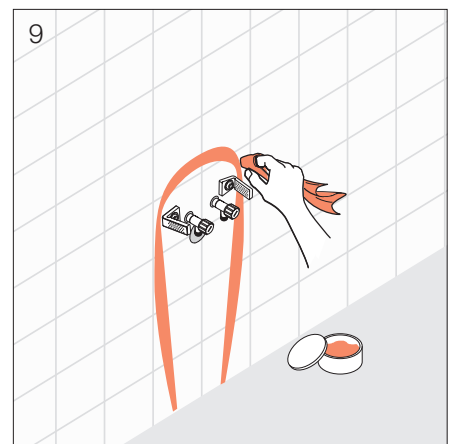
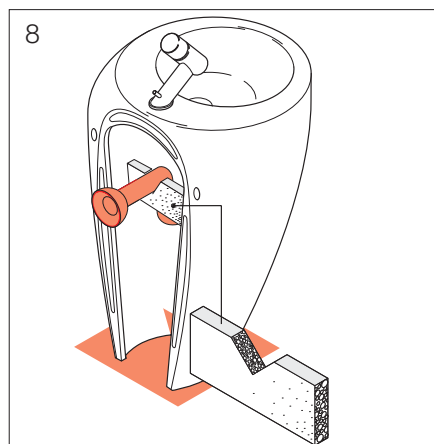
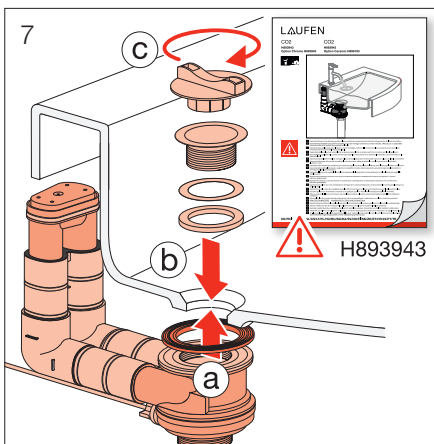
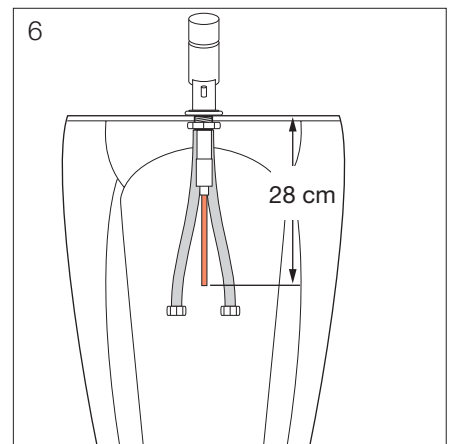
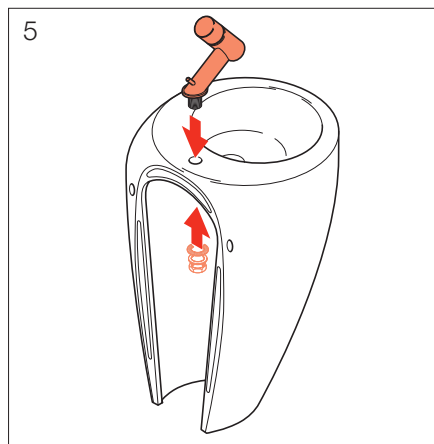
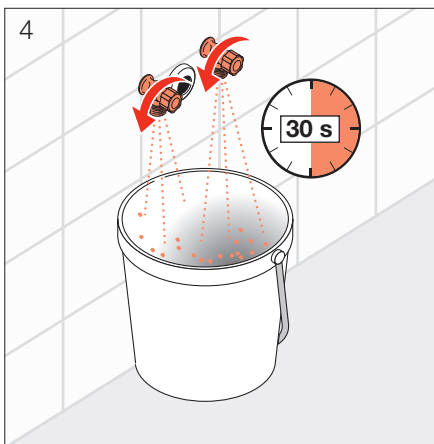
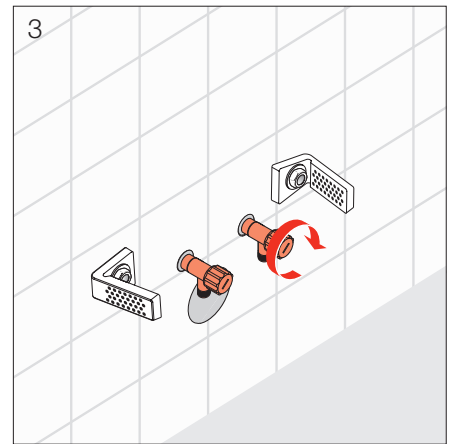
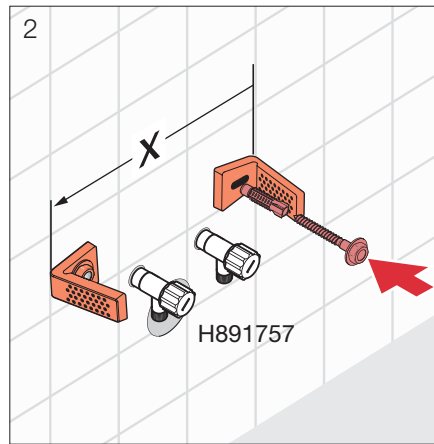
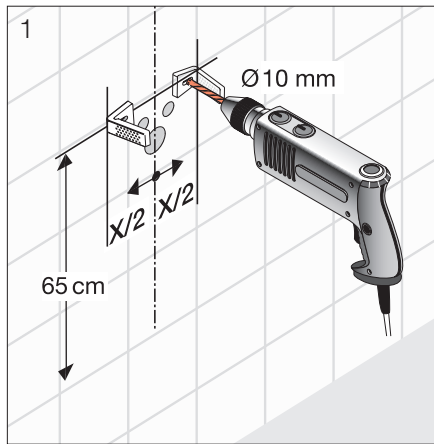

Montageablauf  
Exécution du montage  
Esecuzione del montaggio  
Assembly procedure  
Proceso de montaje

Montageverloop  
Průběh montáže  
Montavimo tvarka  
Odplyw montażowy  
A szerelés menete

Последовательность монтажа  
Протичане на монтажа  
Monteringstrin  
Monteringsprocedur  
Monteringsbeskrivelse

Asennuksen  
Montáž  
装配程序  
Kokkumonteerimine  
Postupak montaže

Montāžas procedūra  
Processo de montagem  
Defășurarea montajului  
Montaj prosedürü  
Uputstvo za montažu  
Navodila za montažo

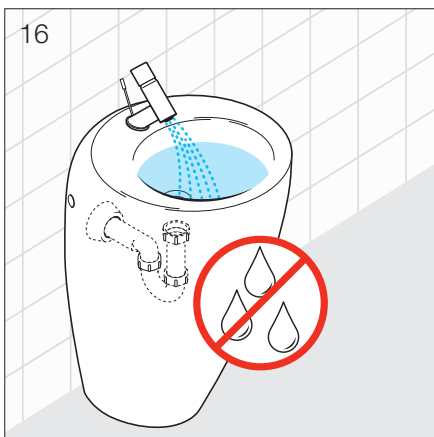
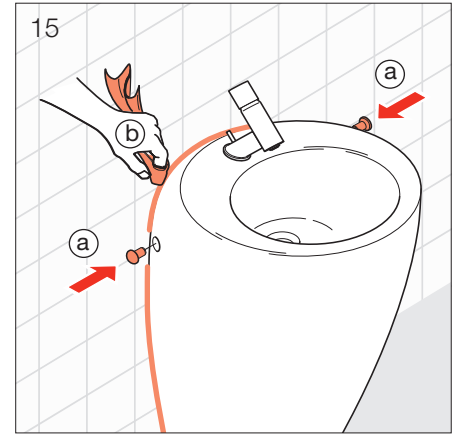
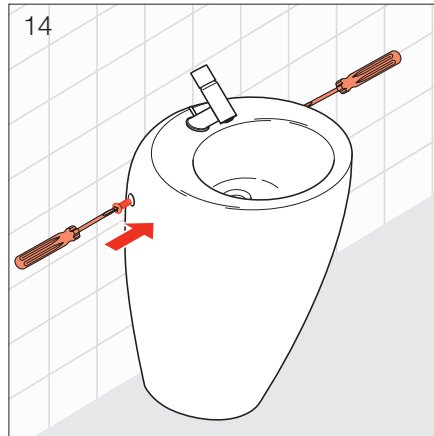
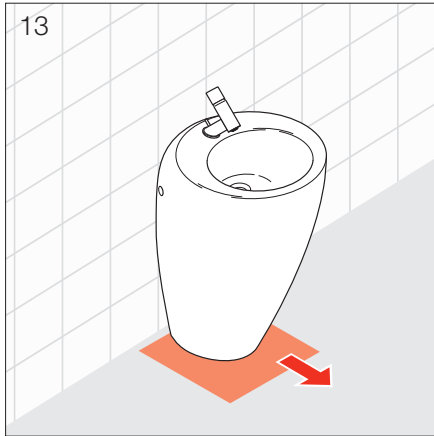

Parts list  
 Contenu du colis  
 Alcance del suministro

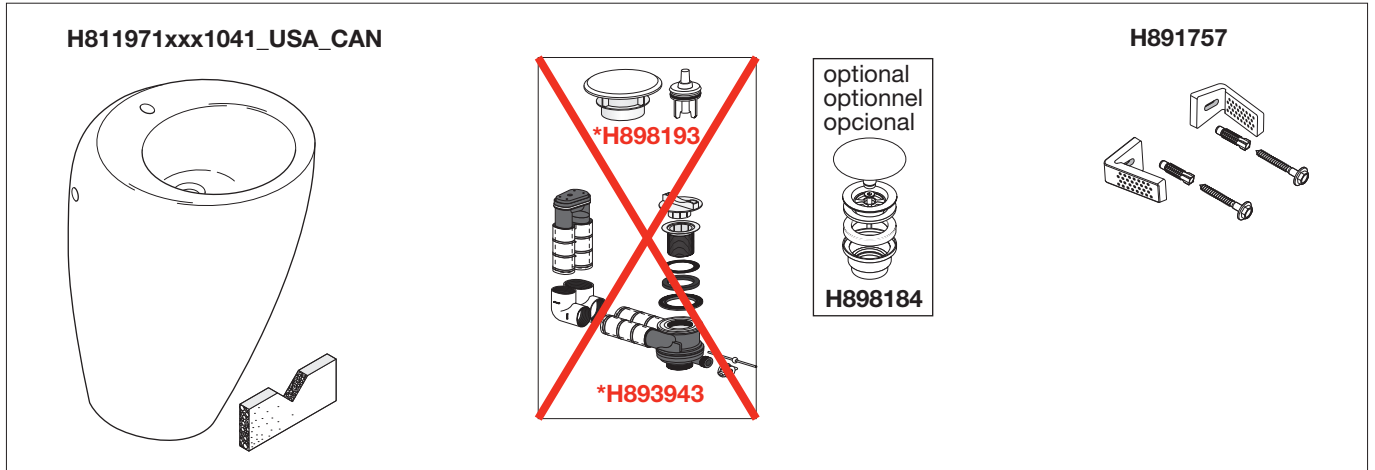

- \* This washbasin has to be made custom field installed complying with the plumbing code; cUPC
- \* Ce lavabo doit être installé conformément aux exigences du code de la plomberie; cUPC
- \* Los complementos del lavabo han de ser acompañados con certificación acreditada; cUPC

Dimensions  
 Dimensions  
 Dimensiones

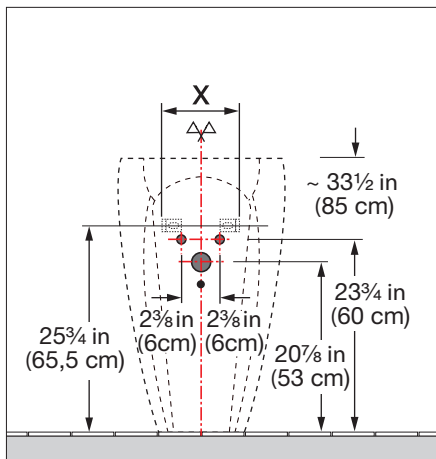



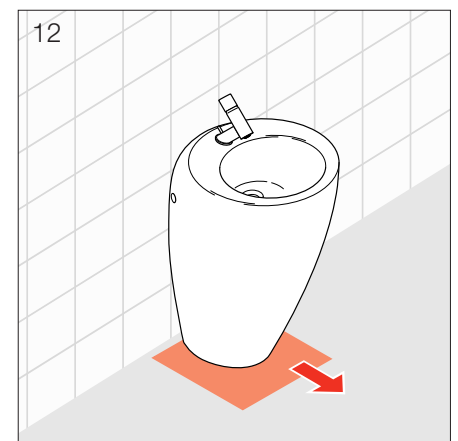
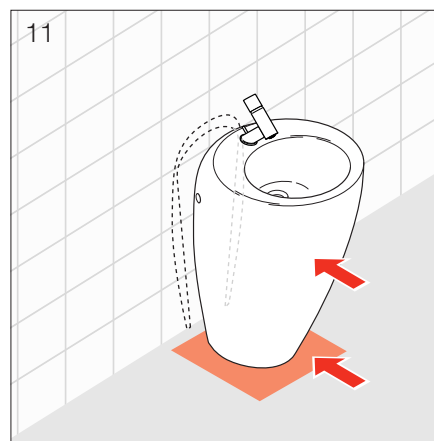
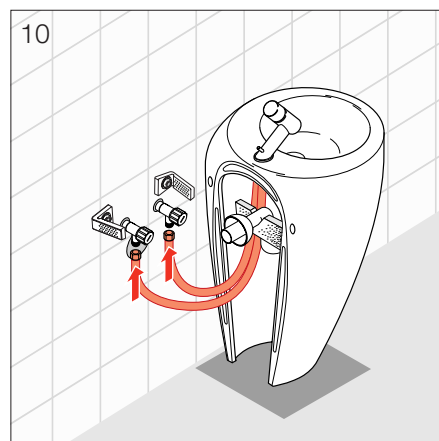
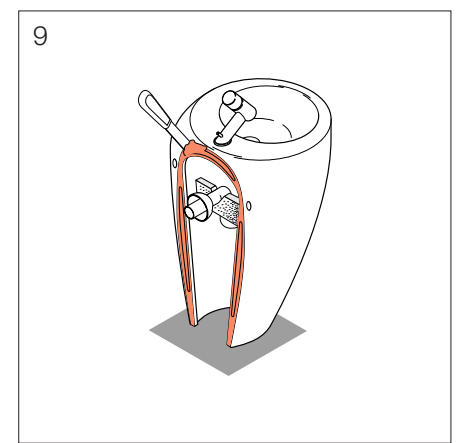
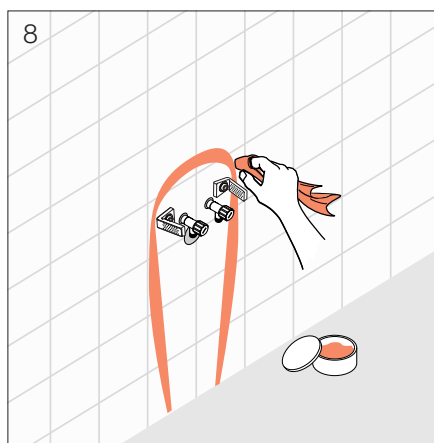
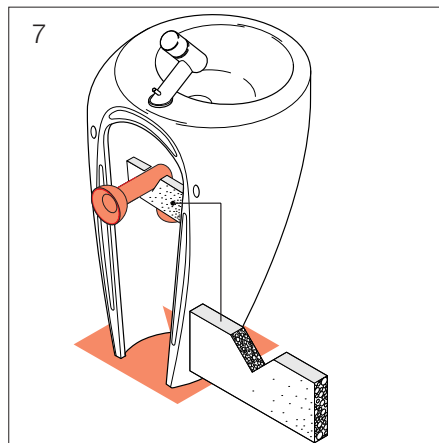
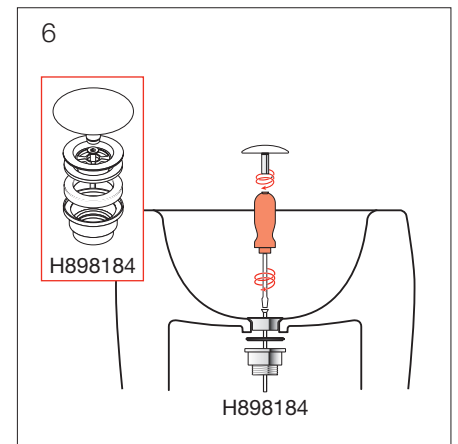
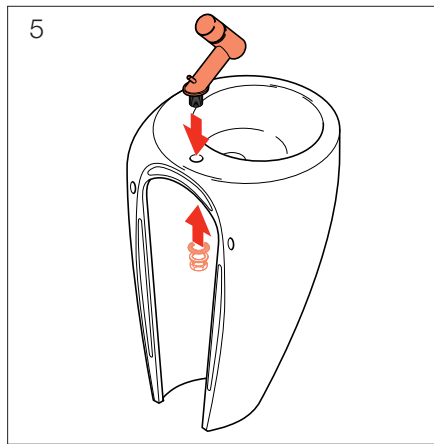
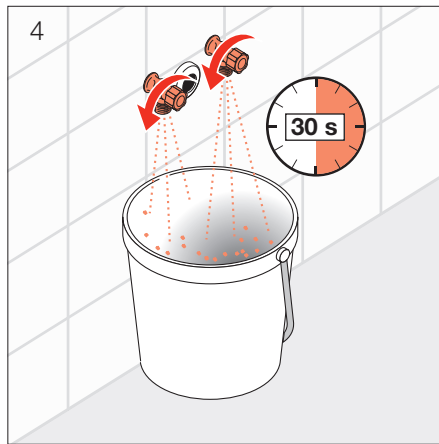
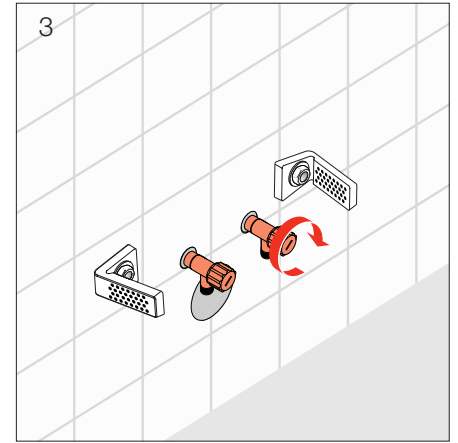
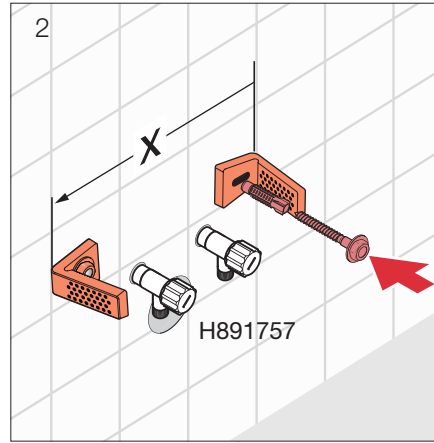
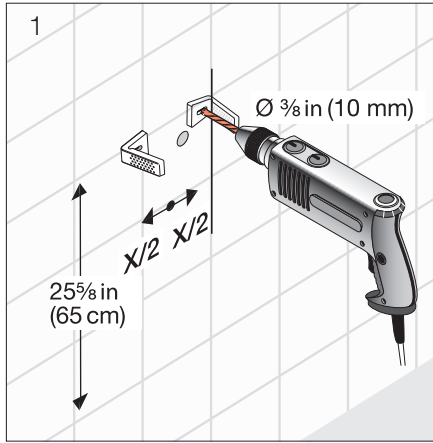

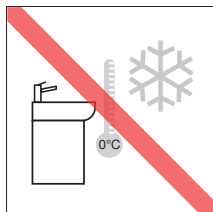
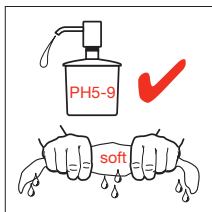
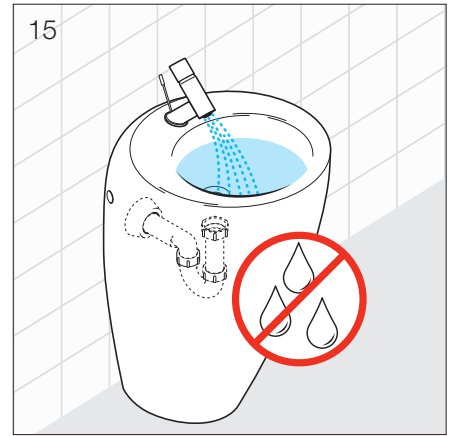
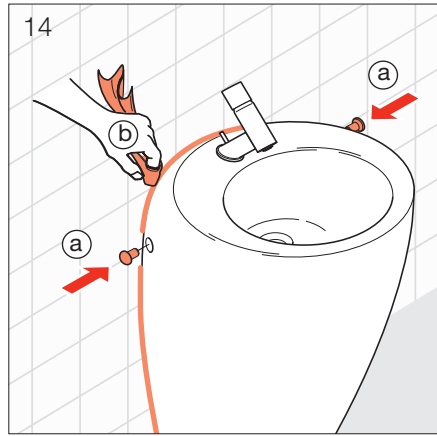
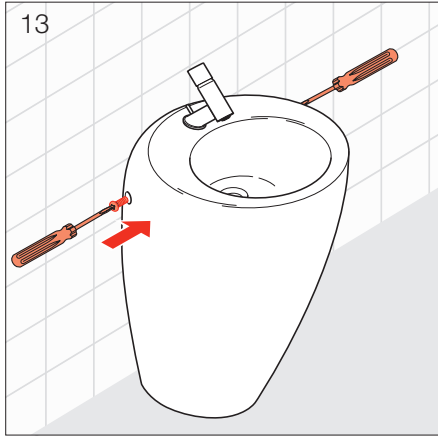



© Laufen Bathrooms AG