



INSTALLATION MANUAL

Natura™ Series White Matte Vessel Bathroom Sink

**KSV-1MW / KSV-2MW / KSV -3MW / KSV-4MW /
KSV-5MW / KSV-6MW**

Thank you for your purchase

We would like to take this opportunity to thank you for choosing Kraus. We hope that you are completely satisfied with your purchase, and enjoy it for years to come. If you have any questions, or require technical assistance, please contact us at 800.775.0703 and one of our representatives will be happy to help.

For more information about Kraus products, please visit:

www.kraususa.com

In order to activate your warranty and get faster access to customer support, please register your new Kraus product at:

www.kraususa.com/registration

Sincerely,

Kraus USA Customer Service

Prior to Installation:

- Inspect the sink prior to installation to make sure it has not been cracked or chipped during shipping
- Observe all plumbing and building codes according to your state requirements
- Additional floor and wall preparation may be required to avoid damaging the sink

WARNING: This product is fragile and can break, chip, or cause injury if handled recklessly. Please consult with a professional when installing

For technical assistance or replacement parts, please contact Kraus Customer Service and one of our representatives will be happy to help:

Toll-Free: 800-775-0703 or customerservice@kraususa.com

The step-by-step guidelines in the installation instructions are a general reference for installing a Kraus Sink. Should there be any discrepancies, Kraus cannot be held liable. It is recommended to install all Kraus products by hiring a licensed professional.

Tools you will need:



Parts List (Included)

• Cleaning Sponge • Buffing Paper

Dimensions

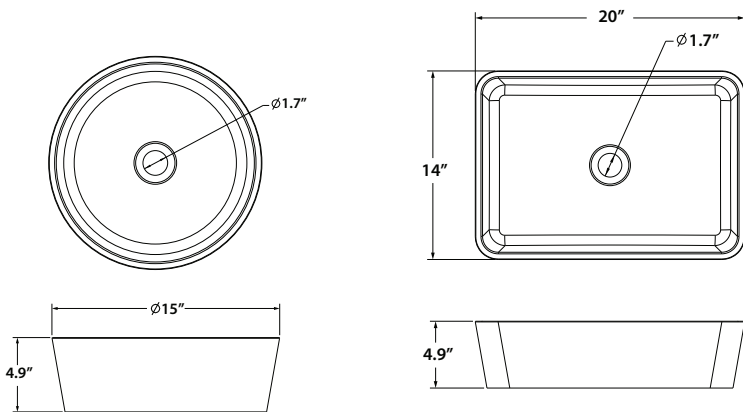

KSV-1MW
15" x 4.9"

KSV-2MW
20" x 14" x 4.9"

Dimensions

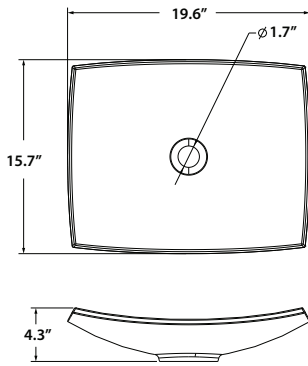

KSV-3MW
19.6" x 15.7" x 4.3"

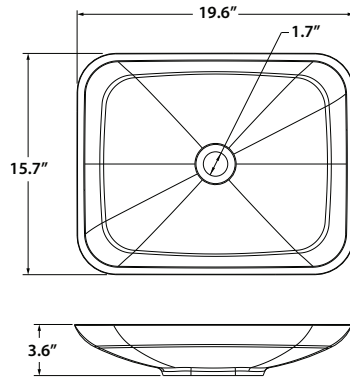

KSV-4MW
19.6" x 15.7" x 3.6"

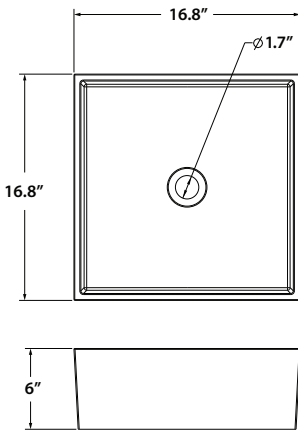

KSV-5MW
16.8" x 16.8" x 6"

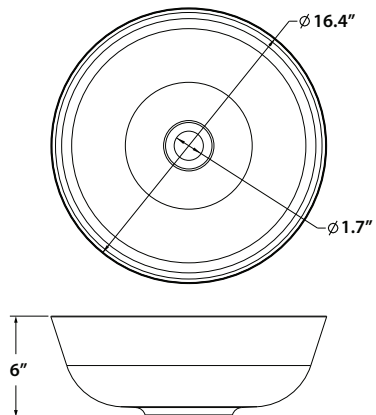

KSV-6MW
16.4" x 6"

1. Mark Faucet and Drain Hole Location

- Place sink in desired location on countertop and mark drain hole and faucet hole centerline with a pencil

NOTE: Make sure clearance is suitable for backsplash, faucet, and sink plumbing

NOTE: Please allow a minimum of 3.5" from wall to edge of sink for faucet placement clearance

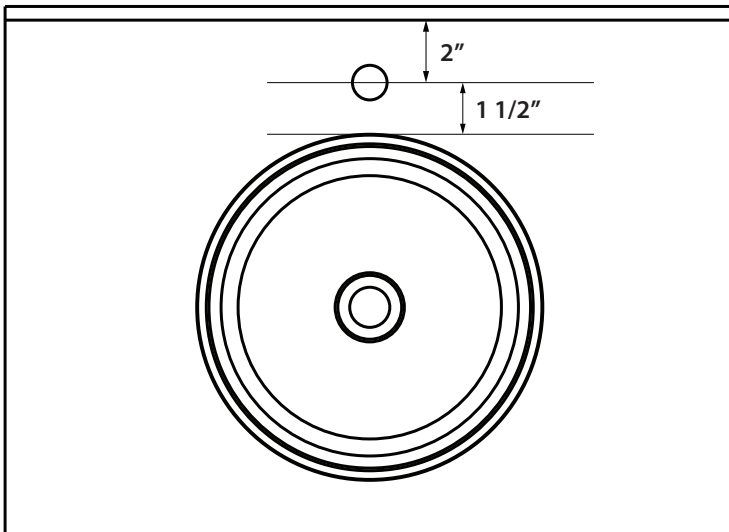

2. Drill Countertop

- Cut the drain opening in the countertop by carefully placing the 4" hole saw on the area marked by pencil

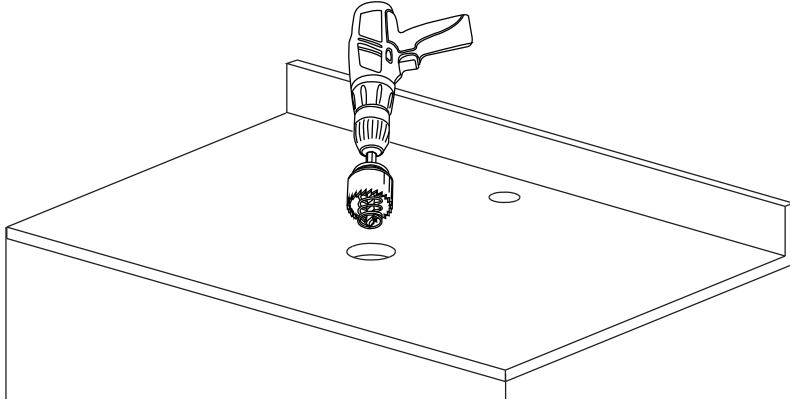

3. Apply Silicone

- Check the alignment of the sink to the opening in the countertop. Use a bead of clear silicone (or preferred adhesive) around the underside of the sink

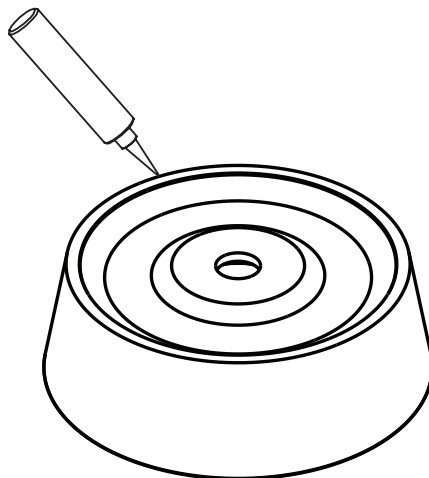

4. Install Sink

- Carefully place the sink on the countertop, align, and press firmly
- Allow sealant to set for 30 – 60 minutes

NOTE: Use acetone or rubbing alcohol to remove any excess sealant immediately after application

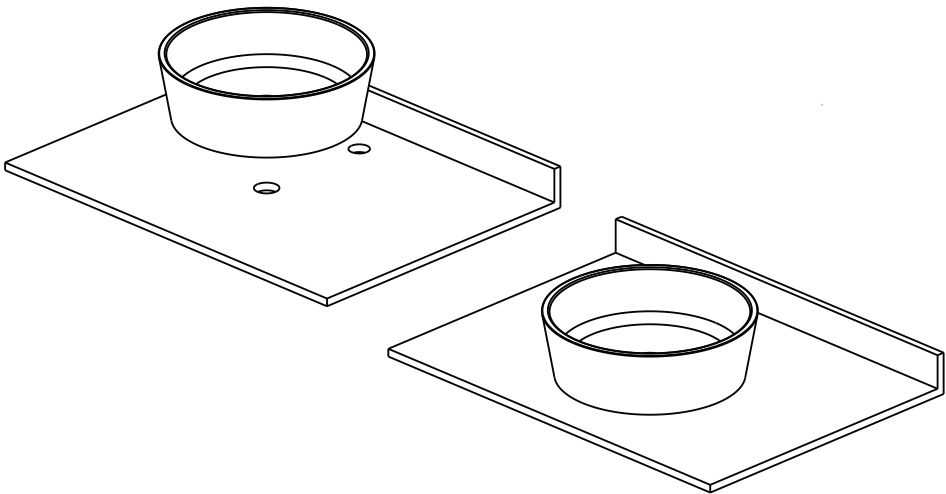

4. Install Plumbing Fixtures

- Connect drain to sink. Connect trap to drain. Connect water supply connections to faucet according to manufacturer's instructions
- Run water into sink and check for leaks

Codes/Standards Applicable:



BATHROOM SINK WARRANTY

Kraus products are manufactured and tested to the highest quality standards by Kraus USA Inc. (“Kraus”).

Kraus extends this warranty to the original purchaser for personal household use of the “Solid Surface Sink” in its original location. The warranty is non-transferable.

Kraus warrants the structure and finish of the product (Solid Surface Sink) to be free from defects in material and workmanship under normal usage for the lifetime of the product. The warranty commences from the initial date of purchase by the owner or trade professional, from an authorized Kraus dealer, through the lifetime of the original owner or end-user.

Any product reported to the authorized dealer or to Kraus as being defective within the warranty period will be repaired or replaced with a product of equal value at the option of Kraus. This warranty extends to the original owner or end-user, and is not transferable to a subsequent owner.

RESTRICTIONS

This warranty does not cover antediluvian, discontinued, or display products, whether such items are purchased at discount outlets, unauthorized dealers, and/or sold on clearance.

This warranty does not cover instances of negligence, misuse, abuse, improper installation, carelessness, accident, hard water or mineral deposits, exposure to corrosive materials, misapplication, damages caused by improper maintenance, alteration of the product, or failure to follow care or installation instructions enclosed with your product. Avoid using abrasive cleaners such as powders, bleach, ammonia, alcohol, or chlorine. Avoid using abrasive pads, steel wool, or wire brushes, as these will damage and wear down the finish.

This warranty does not apply to Products that have not been installed or operated in accordance with instructions supplied by Kraus and all applicable rules, regulations, and legislation pertaining to such installations.

This warranty does not apply unless the Kraus product is installed by a fully insured and licensed trade professional. Kraus insists that such professionals have experience in the installation of bathroom and kitchen manufactured goods.

This warranty does not cover labor charges or costs of removal and reinstallation of said product. This warranty does not allow recovery of incidental or consequential damages, such as loss of use, delay, property damage, or other consequential damages, and Kraus accepts no liability for such damages.

Due to the nature of drain usage, there is no finish warranty on any drain product (including pop-up drains, lavatory drains, and kitchen drains)

This warranty does not cover Marine or Outdoor Installation.

Except as otherwise provided above, Kraus makes no warranties, expressed or implied, including warranties of merchantability and fitness for a particular purpose, or compliance with any code.

Shipping charges will be covered for the first (1) year of the warranted replacement part or product (HI, AK, and Puerto Rico shipping charges may apply). International shipping fees are not included.

COMMERCIAL WARRANTY

Kraus extends the above warranty for a period of one (1) year to purchasers of products for industrial, commercial, and business use.

All incidental or consequential damages are specifically excluded. No additional warranties, express or implied are given, including but not limited to, any implied warranty of merchantability or fitness for a particular purpose.

Some states do not allow the exclusion or limitation of incidental or consequential damages, or limitations on how long an implied warranty lasts, so the above limitations or exclusions may not apply to you.

This warranty gives you specific legal rights, and you may also have other rights which vary from state to state.

If you are a homeowner please contact a Kraus Customer Service Representative at:

Kraus USA, Inc.
12 Harbor Park Drive
Port Washington, NY 11050
Toll-free 800-775-0703
Customerservice@kraususa.com

If you are a plumbing contractor or trade professional please contact a Kraus Pro Representative at:

Kraus USA, Inc.
12 Harbor Park Drive
Port Washington, NY 11050
516-801-8955
Proservice@kraususa.com

If you are an Authorized Partner please contact a Partner Support Representative at:

Kraus USA, Inc.
12 Harbor Park Drive
Port Washington, NY 11050
516-801-8954
Partnersupport@kraususa.com

In requesting warranty service, please be ready to provide:

1. Proof of purchase
2. A description of the problem

Download the Kraus Care & Maintenance Guide at:

<http://www.kraususa.com/maintenance>

REGISTER YOUR PRODUCT TODAY

Receive Proof of Ownership
Access Customer Care & Installation Help
Get Exclusive Kraus Offers & Promotions



Scan to Register Online
or visit <http://www.kraususa.com/registration>

We're always looking for ways to improve.

Please take a moment to share your experience.
Visit <http://www.kraususa.com/review> to let us know what you think
about your new Kraus product.

Contact Us to Learn More
1.800.775.0703 / www.kraususa.com / customerservice@kraususa.com
Like & Follow KrausUSA

Download the Kraus Care & Maintenance Guide at:
<http://www.kraususa.com/maintenance>



Kräus[®]
www.kraususa.com

Kr^äus[®]

INSTALLATION GUIDE

Arlo[™] Single Lever Vessel Faucet

KVF-1200

Congratulations on the purchase of your new Kraus plumbing fixture!

Please keep the box and packaging materials until your product is completely installed. If you have any questions, require technical assistance, or have any problems with your product:



DO NOT RETURN TO STORE

Please contact our Customer Service Team

1-800-775-0703 / customerservice@kraususa.com

Have the model number available, and retain a copy of your receipt with purchase date for reference.

If for any reason this product does not meet your expectations, please be sure to repack this product in the original box and packaging material to avoid damage during transit.

Prior to Installation:

- Make sure you have all necessary parts by checking the diagram and parts list. If any part is missing or damaged, please contact Kraus Customer Service at 800-775-0703 for a replacement
- Turn off the hot and cold water lines at the angle stops and turn on the old faucet to release any built-up pressure
- Pre-drilled countertop hole size requirement: 1-3/8" (min)
- Max countertop thickness: 2"

Diagram and Parts List

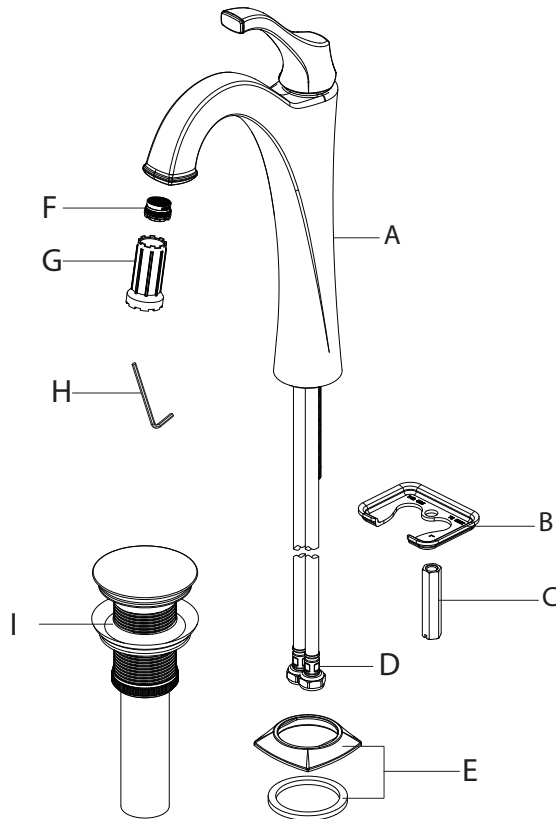

A. Faucet Body
B. Washer
C. Lock Nut

D. Waterlines
E. Flange
F. Aerator

G. Aerator Key
H. Hex Wrench
I. Drain

Faucet Dimension

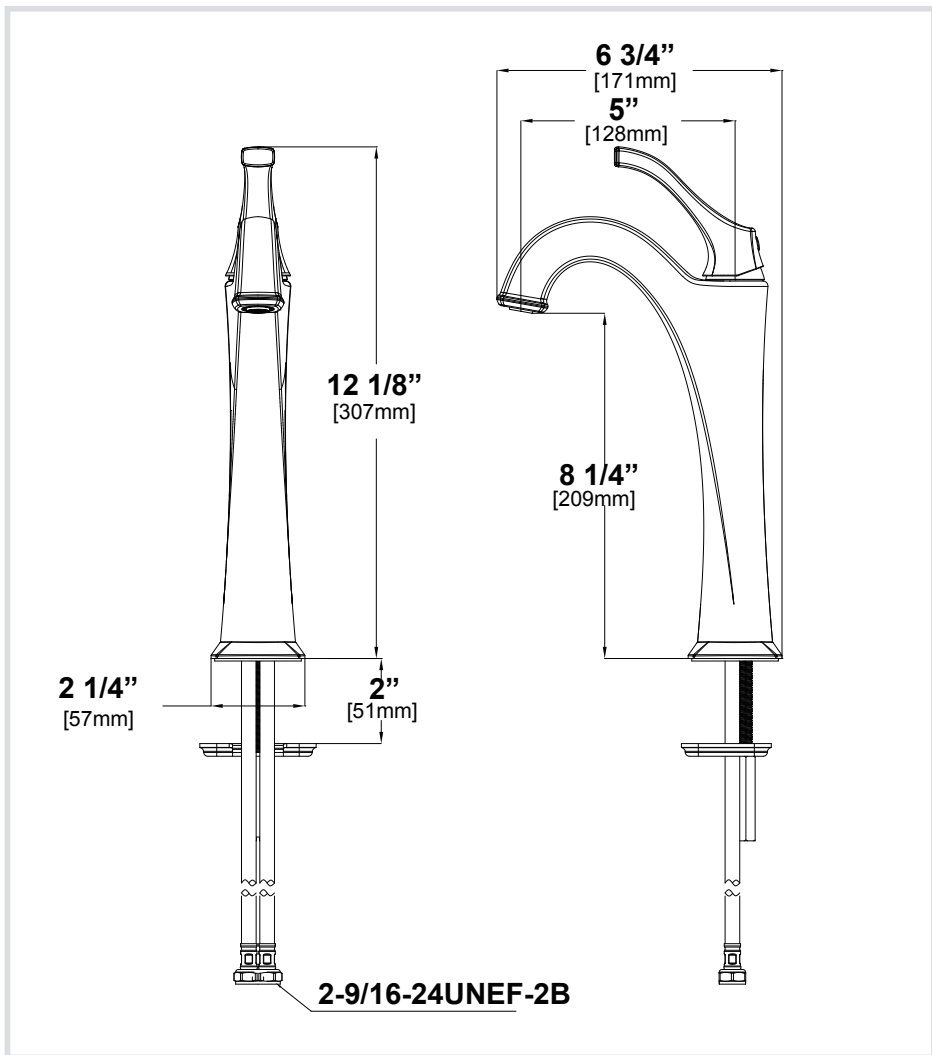

Installer Tip:

Shut off main water supply before installing new faucet

Step 1: Remove washer and lock nut

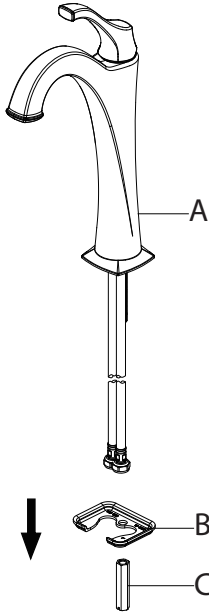

Shut off the water supply. Remove the old faucet. Clean the mounting surface. Remove the washer (B) and lock nut (C) from the faucet (A).

Step 2: Install faucet

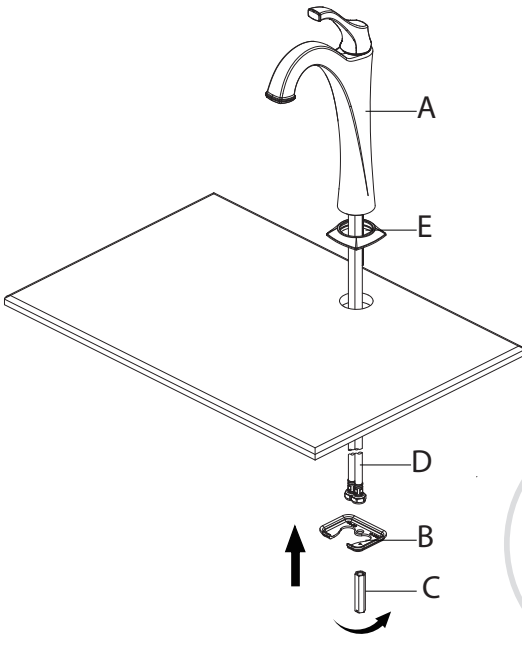

Before installation, ensure that the flange (E) is placed on the bottom of the faucet assembly (A). Place faucet (A) through the 1-3/8" holes in countertop. Secure the faucet (A) to the countertop using the washer (B) and lock nut (C) provided. Ensure the washer (B) and hoses (D) are no interference.

Step 3: Connect waterlines to main valve

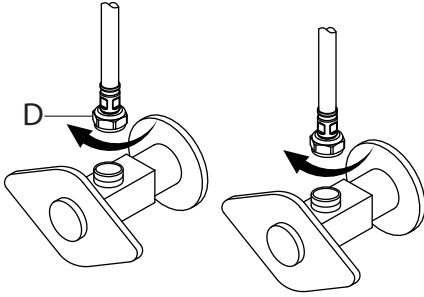

Attach waterlines(D) to angle stops and tighten until snug. Turn on angles stops and check for leaks (DO NOT TURN FAUCET ON)

Step 4: Install Press pop-up assembly

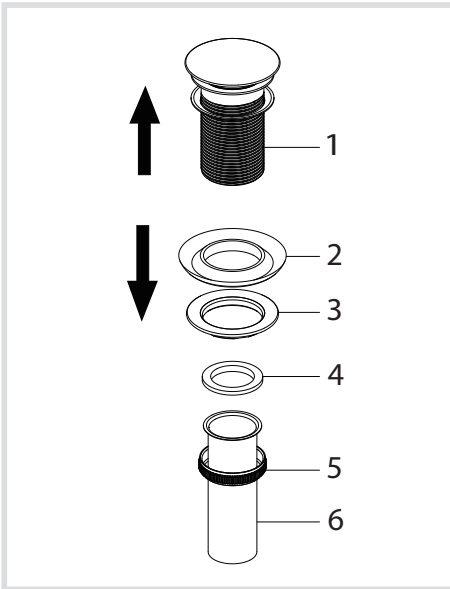

Unscrew the nut (5) from the pop-up body (1), move over the tail pipe (6) and washer (4), then unscrew the coupling nut (3) and remove the washer (2).

Step 4: Install Press pop-up assembly

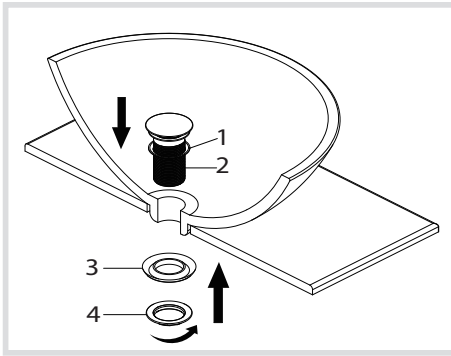

Place the washer (1) underneath the flange of the pop-up body (2). Slide the pop-up body (2) down through the drain hole on the vessel or basin. From underside, slide the washer (3) against the bottom of the vessel or basin, thread on the coupling nut (4) and tighten. Do not overtighten.

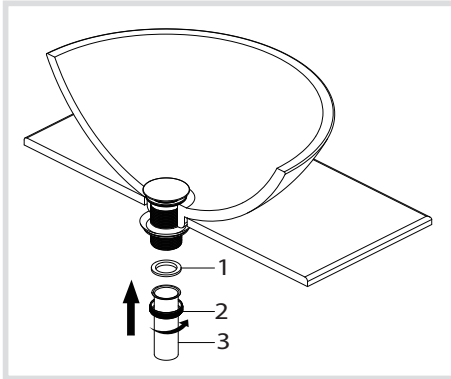

Slide the nut (2) over the tail pipe (3). Place the washer (1) into the nut and tighten. Do not overtighten.

Step 5: Flush faucet

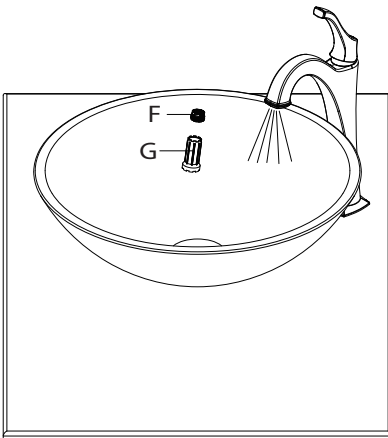

After installing faucet, remove aerator (F) with included aerator key (G). Turn water on for 30 seconds to remove any debris. Reassemble aerator (F).

Replacement Parts

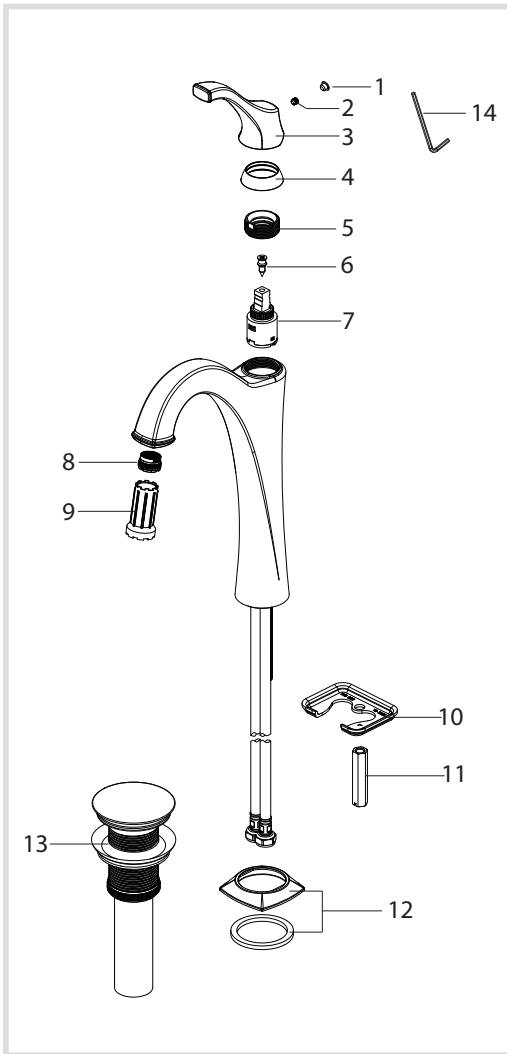

1. Index
2. Set Screw
3. Handle
4. Cap
5. Bonnet Nut
6. Screw
7. Cartridge
8. Aerator
9. Aerator Wrench
10. Washer
11. Lock Nut
12. Flange
13. Press pop-up assembly
14. Hex Wrench

Tools you will need:

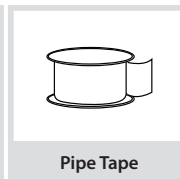
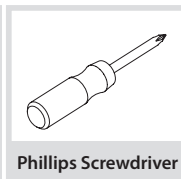
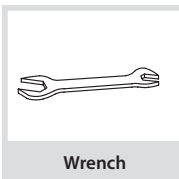

Trouble - Shooting

If you have followed the instructions carefully and your faucet still does not work properly, take the following corrective steps:

PROBLEM	CAUSE	ACTION
Leakage under the handle	Bonnet nut (5) has come loose	Remove the index (1). Loosen set screw (2) with hex wrench (14). Remove the handle (3). Unscrew cap (4) (by hand only). Tighten bonnet nut (5) with an adjustable wrench
Aerator drips or has inconsistent water flow pattern	Aerator (8) is dirty or not seated properly	Unscrew aerator (8) with aerator wrench (9) and clean out debris
Water will not shut off completely	Cartridge may need to be adjusted or replaced	Remove the index (1). Loosen set screw (2) with hex wrench (14). Remove the handle (3). Unscrew cap (4) (by hand only). Tighten bonnet nut (5) with an adjustable wrench. Remove the cartridge (7). Check for cracks
There is leaking from the sink drain at the base of the sink.	The sink has a rough or irregular surface.	Apply additional silicone sealant to the beveled side of the drain flange. Retighten and test for leaks

Care & Maintenance

*To keep the product clean & shining, follow the steps below:

1. Rinse with clean water & dry with a soft cloth
2. Do not clean with soaps, acid, polish, abrasives, or harsh cleaners
3. Do not use cloth with a coarse surface
4. Unscrew the aerator and clean when necessary



*This installation manual is subject to change without further notice.

Codes/Standards Applicable:



Faucet Warranty

Kraus products are manufactured and tested to the highest quality standards by Kraus USA Inc. ("Kraus"). Kraus extends this warranty to the original purchaser for personal household use of the "Faucet" in its original location. The warranty is non-transferable.

Kraus warrants the structure and finish of the product to be free from defects in material and workmanship under normal usage for the lifetime of the product. The warranty commences from the initial date of purchase by the owner or trade professional, from an authorized Kraus dealer, through the lifetime of the original owner or end-user.

Kraus warrants the mechanical components such as but not limited to sprayhead assembly (includes engine, aerators, structure, restrictors, back flow preventers, sprayer hoses, braided supply line hoses which encompass nylon, silicon and stainless steel, etc) of the product to be free from defects in material and workmanship under normal usage for a period of one (1) year. The warranty commences from the initial date of purchase by the owner or trade professional, from an authorized Kraus dealer, through the one (1) year term of the original owner or end-user.

Kraus warrants the mechanical component (cartridge) of the product to be free from defects in material and workmanship under normal usage for a period of five (5) years. The warranty commences from the initial date of purchase by the owner or trade professional, from an authorized Kraus dealer, through the five (5) year term of the original owner or end-user.

Any product reported to the authorized dealer or to Kraus as being defective within the warranty period will be repaired or replaced with a product of equal value at the option of Kraus. This warranty extends to the original owner or end-user, and is not transferable to a subsequent owner.

Restrictions

This warranty does not cover antediluvian, discontinued, or display products, whether such items are purchased at discount outlets, unauthorized dealers, and/or sold on clearance.

This warranty does not cover instances of negligence, misuse, abuse, improper installation, carelessness, accident, hard water or mineral deposits, exposure to corrosive materials, misapplication, damages caused by improper maintenance, alteration of the product, or failure to follow care or installation instructions enclosed with your product. Avoid using abrasive cleaners such as powders, bleach, ammonia, alcohol, or chlorine. Avoid using abrasive pads, steel wool, or wire brushes, as these will damage and wear down the finish. This warranty does not apply to Products that have not been installed or operated in accordance with instructions supplied by Kraus and all applicable rules, regulations, and legislation pertaining to such installations.

This warranty does not apply unless the Kraus product is installed by a fully insured and licensed trade professional. Kraus insists that such professionals have experience in the installation of bathroom and kitchen manufactured goods.

This warranty does not cover labor charges or costs of removal and reinstallation of said product. This warranty does not allow recovery of incidental or consequential damages, such as loss of use, delay, property damage, or other consequential damages, and Kraus accepts no liability for such damages.

This warranty does not cover Marine or Outdoor Installation.

Except as otherwise provided above, Kraus makes no warranties, expressed or implied, including warranties of merchantability and fitness for a particular purpose, or compliance with any code.

Shipping charges will be covered for the first (1) year of the warranted replacement part or product (HI, AK, and Puerto Rico shipping charges may apply). International shipping fees are not included.

Commercial Warranty

Kraus extends the above warranty for a period of one (1) year to purchasers of products for industrial, commercial, and business use.

All incidental or consequential damages are specifically excluded. No additional warranties, express or implied, are given, including but not limited to any implied warranty of merchantability or fitness for a particular purpose. Some states do not allow the exclusion or limitation of incidental or consequential damages or limitations on how long an implied warranty lasts, so the above limitations or exclusions may not apply to you. This warranty gives you specific legal rights, and you may also have other rights which vary from state to state.

If you are a homeowner please contact a Kraus Customer Service Representative at:

Kraus USA, Inc.
12 Harbor Park Drive
Port Washington, NY 11050
Toll-free 800-775-0703
Customerservice@kraususa.com

If you are a plumbing contractor or trade professional please contact a Kraus Pro Representative at:

Kraus USA, Inc.
12 Harbor Park Drive
Port Washington, NY 11050
516-801-8955
Proservice@kraususa.com

If you are an Authorized Partner please contact a Partner Support Representative at:

Kraus USA, Inc.
12 Harbor Park Drive
Port Washington, NY 11050
516-801-8954
Partnersupport@kraususa.com

In requesting warranty service, please be ready to provide:

1. Proof of purchase.
2. A description of the problem.

Download the Kraus Care & Maintenance Guide at:

<http://www.kraususa.com/maintenance>

IMPORTANT

Register Your Kraus Product

Activate Your Warranty

Access Premium Customer Support

Get Product Information

REGISTER TODAY

<http://www.kraususa.com/registration>



Kräus[®]
www.kraususa.com