

**PHILLIPE 55"  
FREESTANDING  
ACRYLIC TUB**

Cat. No.  
ATOVN55D



L: 55-1/4"  
W: 27-3/8"  
H: 23-1/2"

Water depth: 17-3/8" to top of tub

**The following is recommended for ATOVN55D tubs:**

- Faucets: part #4602,4604, 7082 or 7088
- Rigid, freestanding supplies: part #4502
- Freestanding filler: part #7932, 7952 or 7918  
(Does not need bath supplies)
- Leg tub drain: part #5599LT or 5599TS



Overflow can be drilled. With overflow drilled this tub requires drain 5599PD. **Tubs that have been drilled with overflow are "special order" and are not returnable.**

Gallon Capacity without OF: 48  
Shipping Weight: 148 lbs.  
Empty Weight: 82 lbs.  
Filled Weight without OF: 483 lbs.

**Features:**

- ▶ Acrylic construction for lighter weight
- ▶ Interior and exterior walls acrylic sheets
- ▶ Air between walls provides insulation to help retain warmth
- ▶ Rim is 1-1/2" wide
- ▶ No faucet holes
- ▶ No overflow
- ▶ Tub is thoroughly inspected before shipment



**WARNING:** This product can expose you to chemicals, including Toluene and Styrene, which are known to the state of California to cause cancer and birth defects or other reproductive harm.

For more information go to [www.P65Warnings.ca.gov](http://www.P65Warnings.ca.gov)

**Custom Colors Available** (inside of tub is always white enamel):  
Painted bathtubs are considered "special order" and are not returnable  
\$160 Bisque or Black \$250 Designer Color

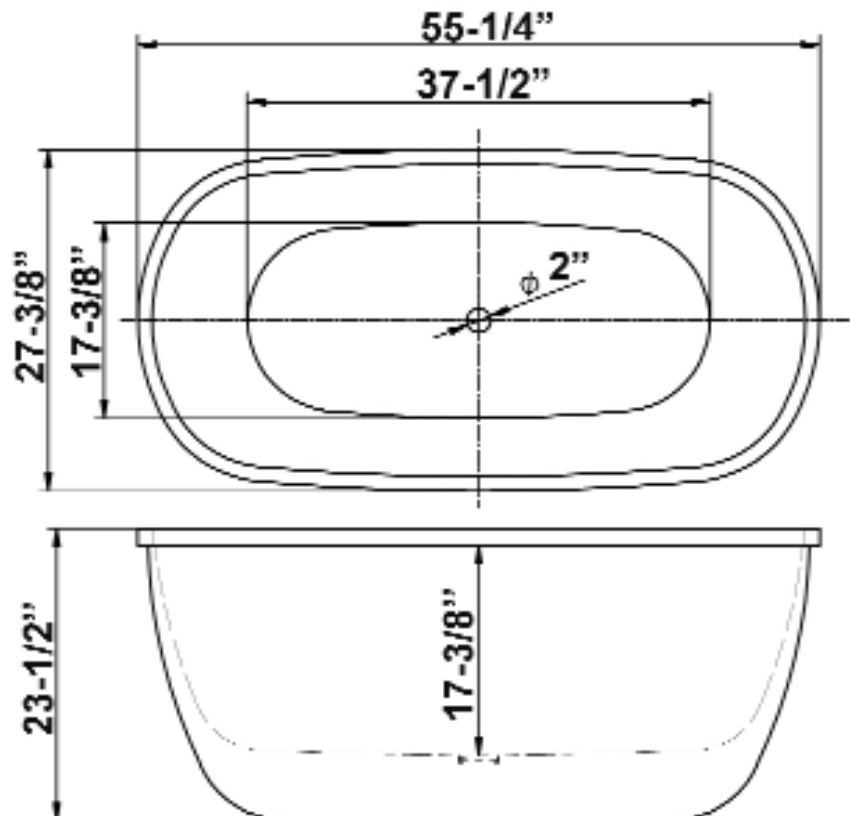

Dimensions of fixture are nominal and specifications subject to change without notice.