

**YARBOROUGH
61" ACRYLIC
SLIPPER TUB**

Cat. No.
ATRNDN61



BARCLAY



Diameter 61"
H: 23-3/4"

Water depth: 17" to top of tub

Features:

- ▶ Interior and exterior walls acrylic sheets
- ▶ Air between sheets provides insulation to help retain warmth
- ▶ No faucet holes
- ▶ No overflow
- ▶ Tub is thoroughly inspected before shipment



Custom Colors Available (inside of tub is always white enamel):
Painted bathtubs are considered "special order" and are not returnable

The following is recommended for ATRNDN61 tubs:

- Faucets: part #7082 or 7088
- Rigid, freestanding supplies: part #4502
- Leg tub drain: part #5599LT

Gallon Capacity: 120
Shipping Weight: 470 lbs.
Empty Weight: 220 lbs.
Filled Weight: 1,222 lbs.

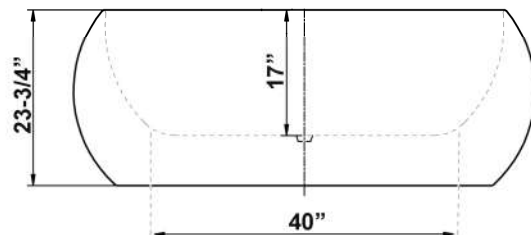
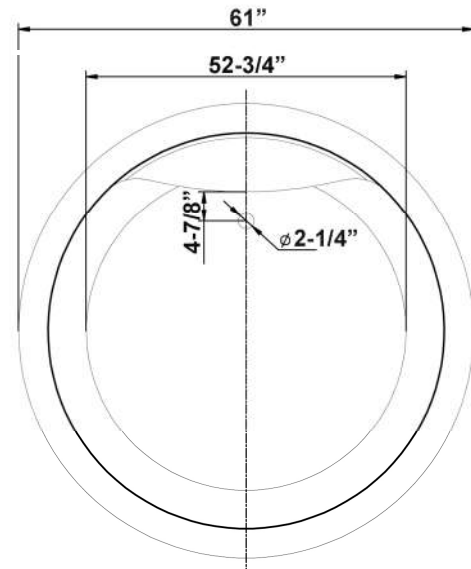

Dimensions of fixture are nominal and specifications subject to change without notice.

09/19/2017

P 847•244•1234

www.barclayproducts.com