

**SLOANE 59”  
RECTANGULAR  
ACRYLIC TUB**

Cat. No.  
ATFRECN59A



L: 59”  
W: 30”  
H: 24”

Water depth: 18-1/2” to top of tub  
Water depth: 14” to overflow

**The following is recommended for  
ATFRECN59A tubs:**  
•Faucet: part #7901 or 7913  
•Leg tub drain: part #5599LT



Overflow can be drilled.  
With overflow drilled this tub  
requires drain 5599PD.  
**Tubs that have been  
drilled with overflow are  
“special order” and  
are not returnable.**

Gallon Capacity without OF:	46
Gallon Capacity with OF:	39
Shipping Weight:	215 lbs.
Empty Weight:	105 lbs.
Filled Weight without OF:	489 lbs.
Filled Weight with OF:	431 lbs.

**Features:**

- ▶ Interior and exterior walls acrylic sheets
- ▶ Air between sheets provides insulation to retain warmth
- ▶ Rim ends are 2-3/4” wide side are 1”
- ▶ No faucet holes
- ▶ No overflow
- ▶ Includes built-in adjusters
- ▶ Tub is thoroughly inspected before shipment
- ▶ Option to add foam insulation between tub walls available



**Custom Colors Available** (inside of tub is always white enamel):  
Painted bathtubs are considered “special order” and are not returnable  
\$160 Bisque or Black \$250 Designer Color

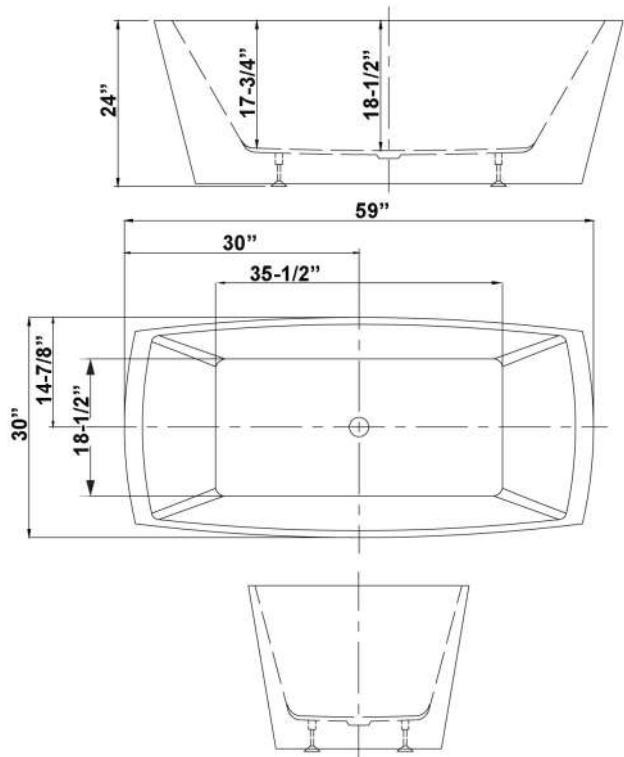

Dimensions of fixture are nominal and specifications subject to change without notice.