

**TAYLOR
67" ACRYLIC
RECTANGULAR TUB**

Cat. No.
ATCRECN67F

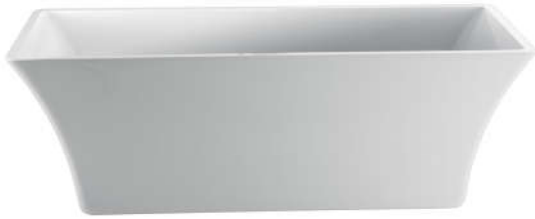

L: 66-3/8"
W: 29-1/4"
H: 22-3/8"

Water depth: 17-3/8" to top of tub
Water depth: 13-1/2" to OF

The following is recommended for ATCRECN67F tubs:
•Faucets: part #7901 or 7913
•Leg tub drain: part #5599LT



Overflow can be drilled.
With overflow drilled this tub requires drain 5599PD.
Tubs that have been drilled with overflow are "special order" and are not returnable.

Gallon Capacity without OF:	58
Gallon Capacity with OF:	49
Shipping Weight:	294 lbs.
Empty Weight:	94 lbs.
Filled Weight without OF:	578 lbs.
Filled Weight with OF:	503 lbs.

Features:

- ▶ Acrylic construction for lighter weight
- ▶ Air between sheet provides insulation to help retain warmth
- ▶ Option to add foam insulation between tub walls
- ▶ Sleek design compliments many decors
- ▶ For use with a freestanding tub filler or faucet mounted on the wall
- ▶ No faucet holes
- ▶ No overflow
- ▶ Tub is thoroughly inspected before shipment



Custom Colors Available (inside of tub is always white enamel):
Painted bathtubs are considered "special order" and are not returnable
\$160 Bisque or Black \$250 Designer Color

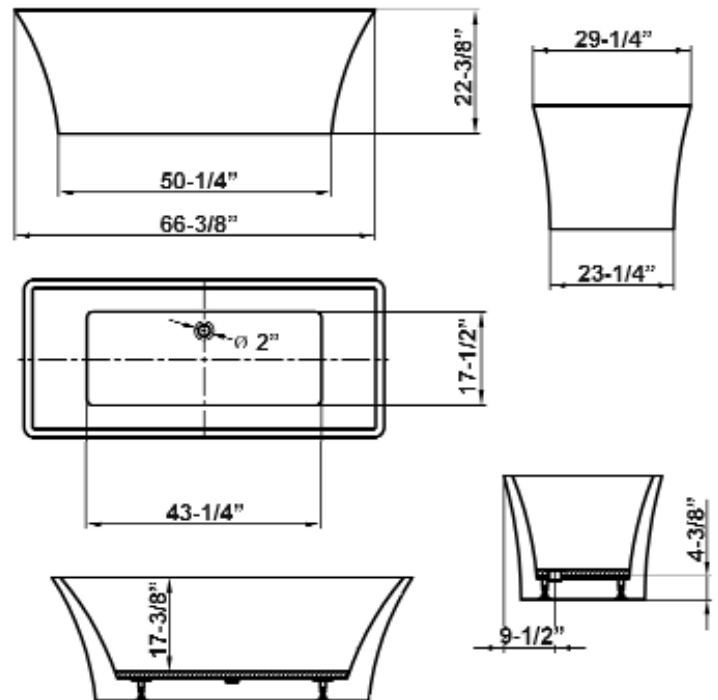

Dimensions of fixture are nominal and specifications subject to change without notice.