

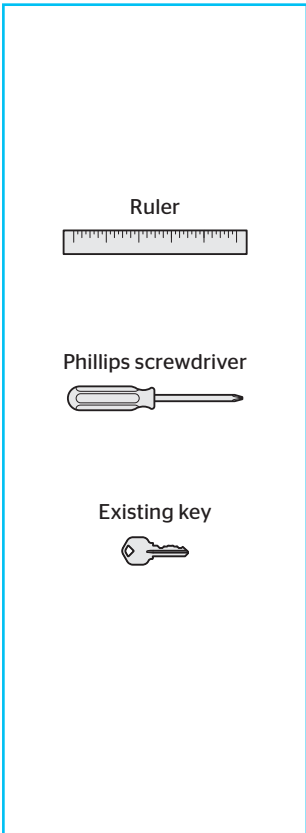

# kēvo CONVERT

### Required tools



### Parts in the box

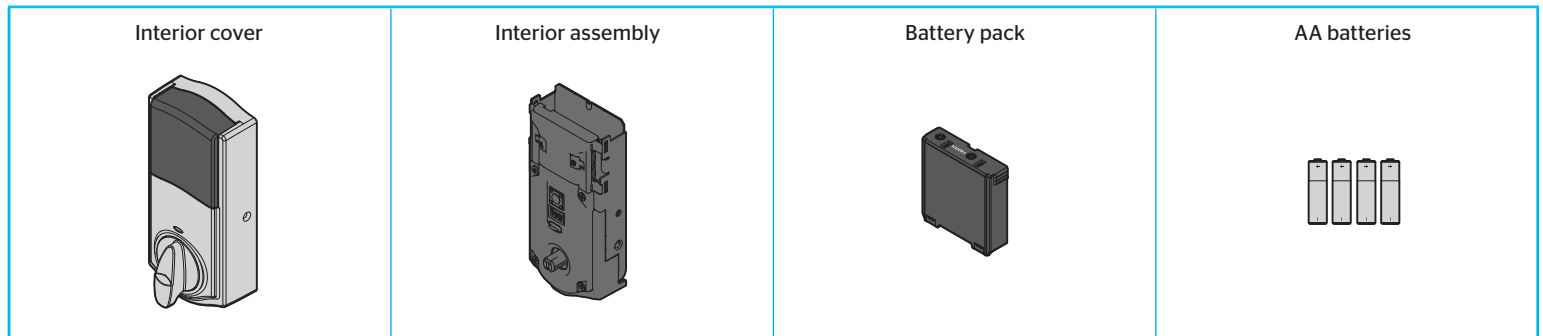
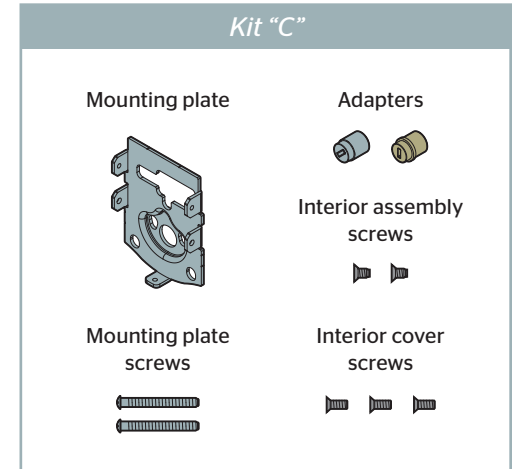
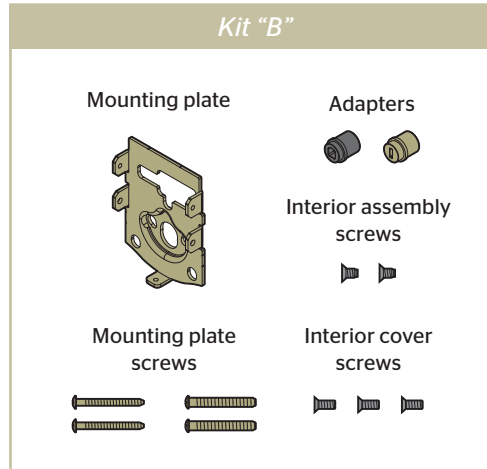
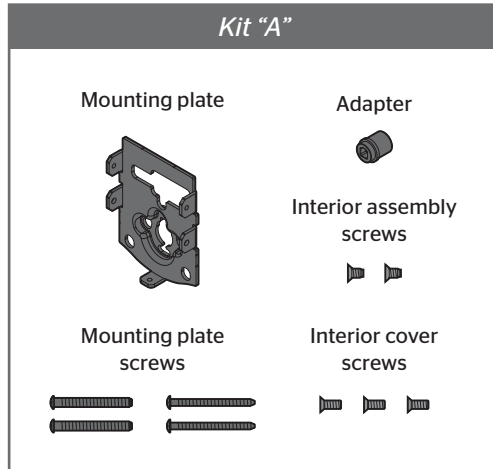

# 1 Make sure your existing deadbolt is compatible.

If you have a standard deadbolt mounted separately from the handle below it, it is compatible with Kevo Convert.

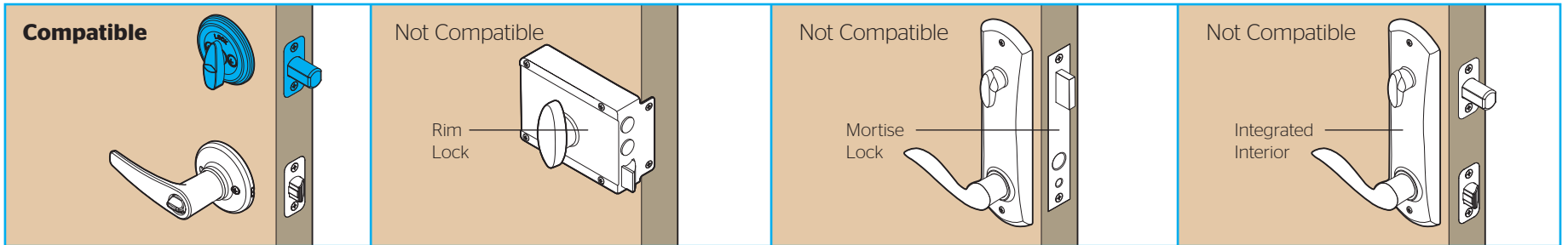

# 2 Measure the thickness of your door.

Measure to confirm that your door is either 1-3/8" or 1-3/4" (35 mm or 44 mm) thick.

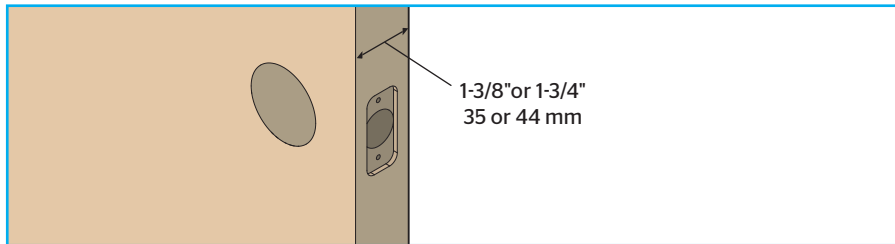

# 3 Disassemble your existing deadbolt.

**A** Make sure your door is open and extend your latch bolt.

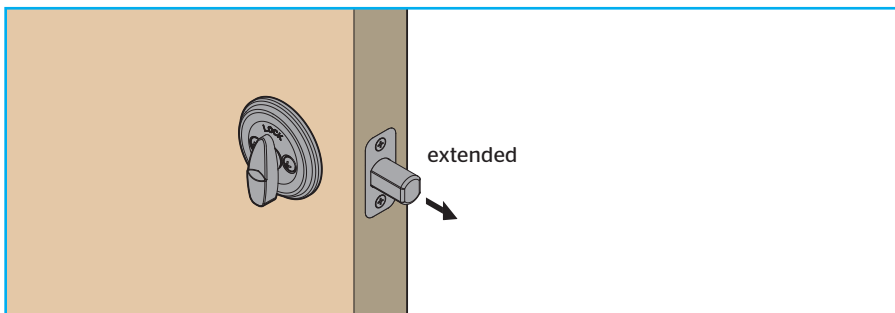

**B** Remove all existing deadbolt hardware from the interior side of your door. Keep your deadbolt exterior in place.

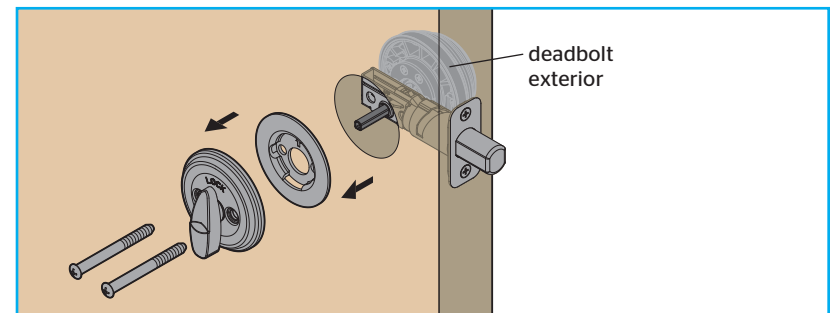

# 4

## Determine the parts needed for your door.

Look at the hole in your door.  
What shape is your torque blade (the part sticking out through the latch)?

*D-shape*

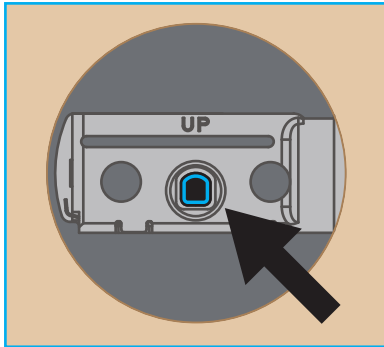

**Kwikset and Weiser deadbolts:**

Use kit "A" for your door.

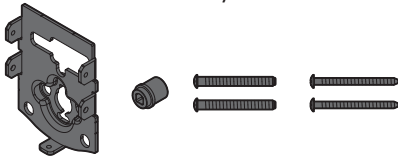

**Baldwin Reserve and Baldwin Prestige deadbolts:**

Use kit "B" for your door.

You will need the black adapter and the thicker gold screws.

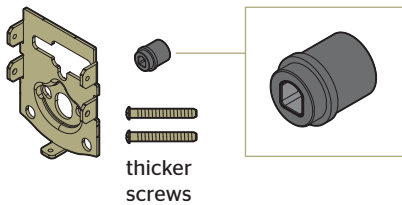

*Vertical rectangle*

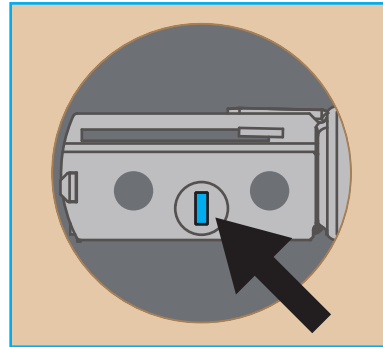

**Baldwin Estate deadbolts:**

Use kit "B" for your door.

You will need the gold adapter and the thinner gold screws.

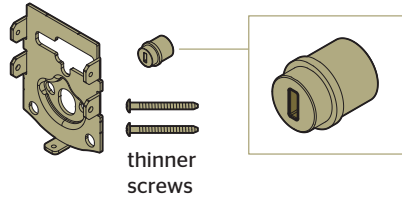

*Slanted rectangle*

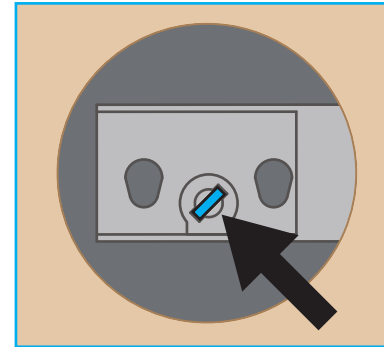

**Schlage deadbolts:**

Use kit "C" for your door.

You will need the silver adapter.

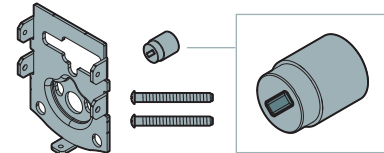

*Horizontal rectangle*

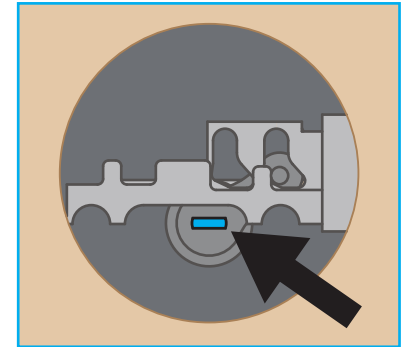

**Schlage deadbolts:**

Use kit "C" for your door.

You will need the gold adapter.

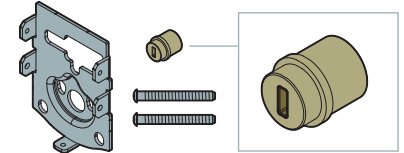

For a list of compatible deadbolt models, see page 11.

## 5 Install the mounting plate and test your latch.

- A** Place the mounting plate on the door so that the torque blade inserts through the center hole.

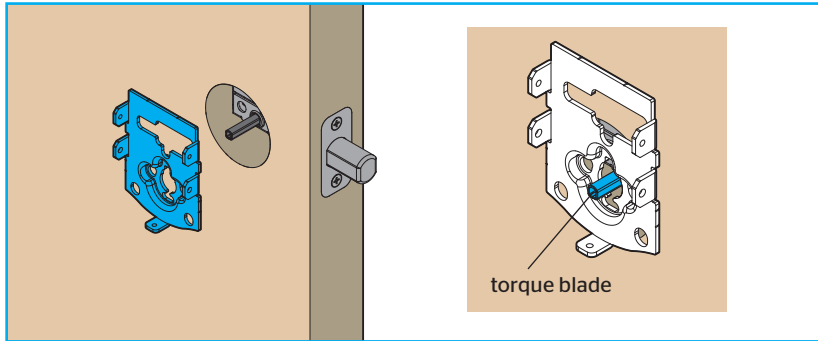

Note: A D-shaped torque blade is shown, but installation is the same for all models.

- B** Secure the mounting plate with the mounting screws.

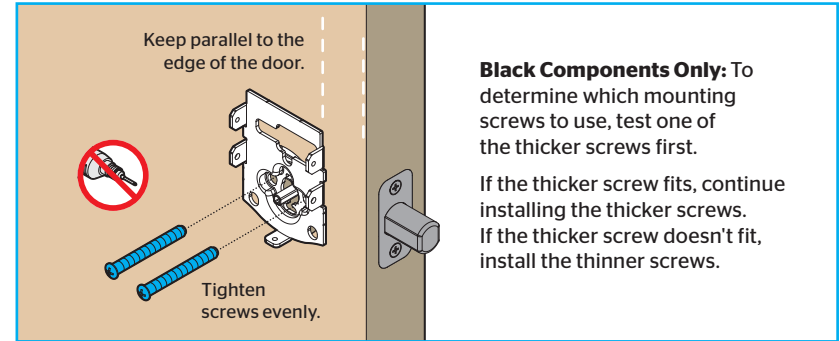

- C** Insert your key and test the latch for smooth operation.

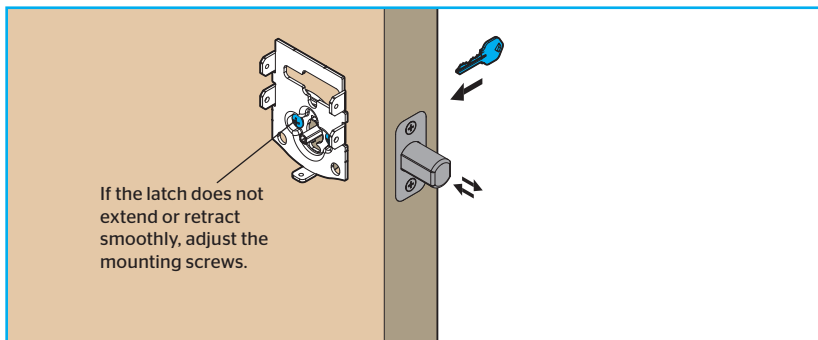

- D** Remove your key and make sure the bolt is fully extended.

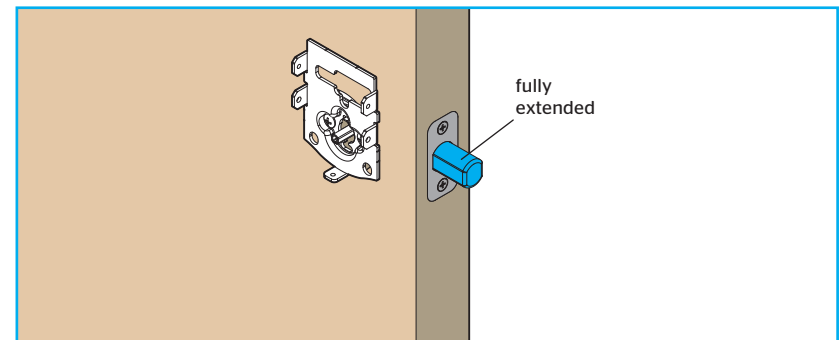

## 6 Install the interior assembly.

### A Prepare the interior assembly.

- a** Make sure the turnpiece is in the vertical position.

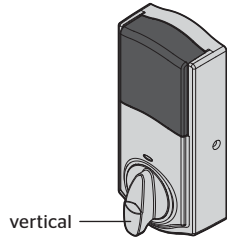

- b** Remove the interior cover.

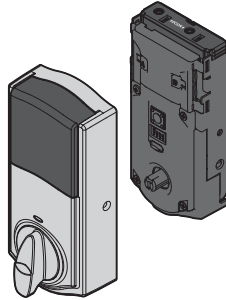

- c** Make sure shaft is oriented as shown. If needed, rotate the shaft to this position.

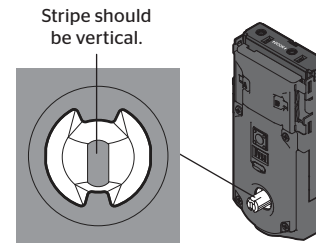

- d** Remove the battery pack.

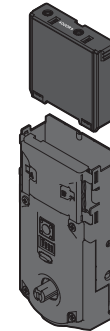

Do not install batteries yet.

### B Install the adapter on the interior assembly.

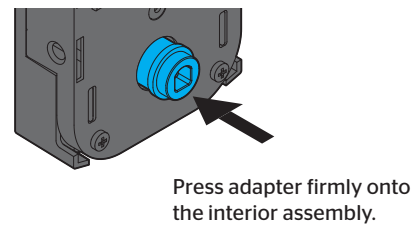
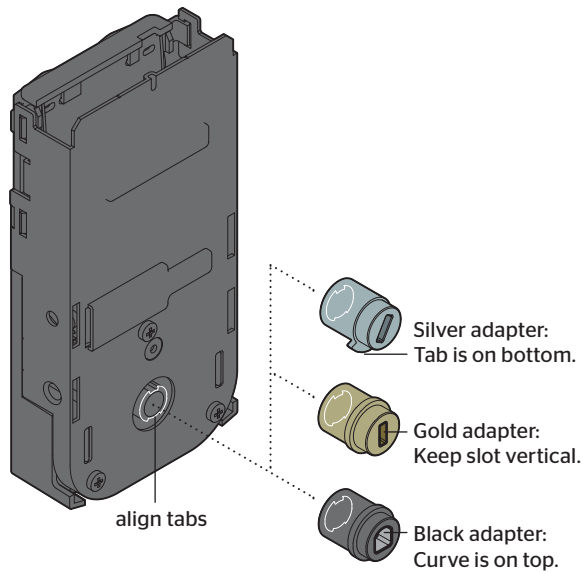

# 6

## Install the interior assembly (continued).



### SCHLAGE DEADBOLTS ONLY:

Look at your mounting plate.  
Is your latch bolt to the left or right of your mounting plate?

*Left*

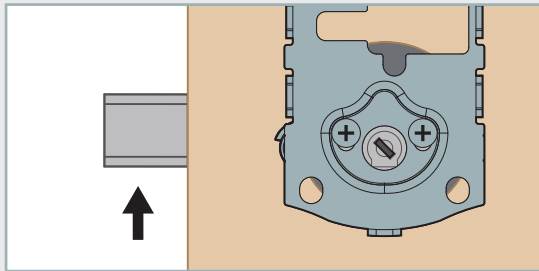

No adjustment is required.  
Proceed to the next page.

*Right*

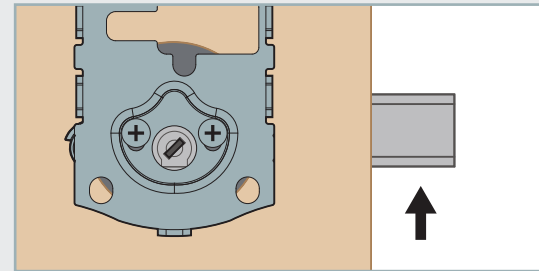

On your interior assembly, flip switch #2  
to the top position.

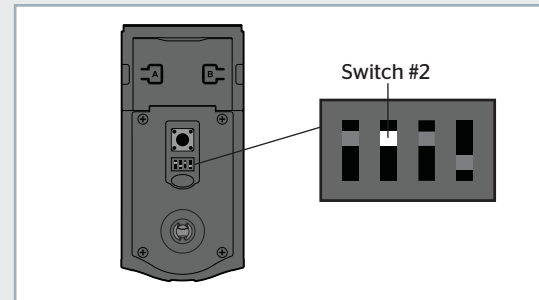

## 6 Install the interior assembly (continued).

C Install the interior assembly onto the mounting plate.

**a** Align the adapter with the torque blade.

**Schlage deadbolts only:**

You may need to rotate the adapter to align with the torque blade.

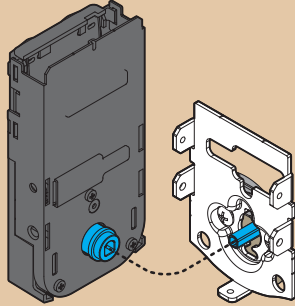

**b** Secure with two (2) interior assembly screws.

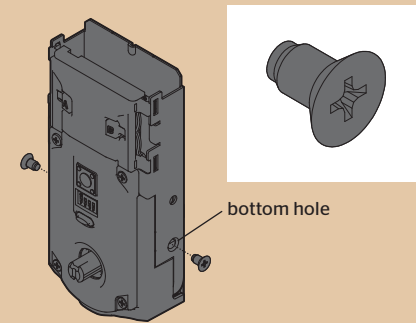

## 7 Perform the door handing process.

This step will teach the lock the orientation of your door and is crucial for lock operation.

**A** Install 4 AA batteries in the battery pack.

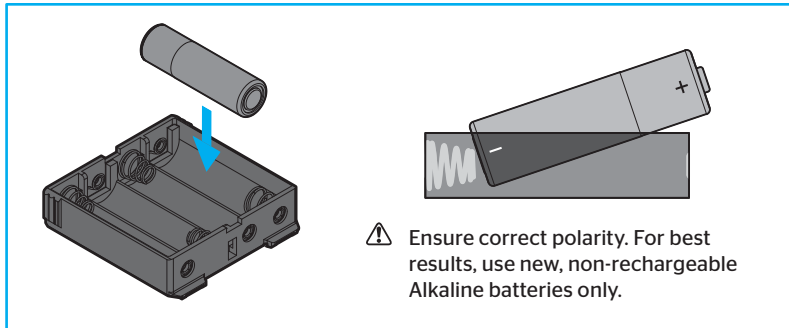

**B** **IMPORTANT:** Make sure the door is open. Insert the battery pack while **PRESSING AND HOLDING** the Program button. Release the button when the battery pack is all the way inside the lock interior.

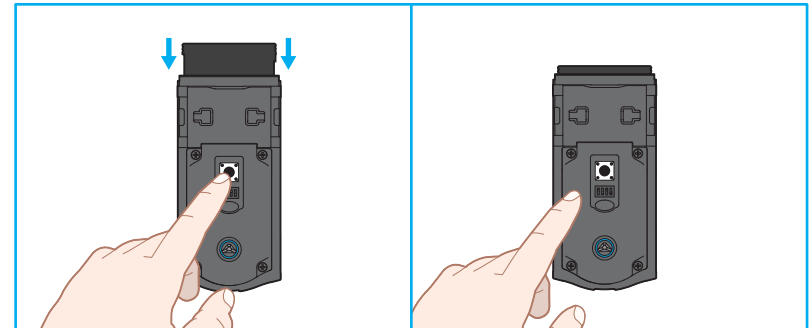

**C** **IMPORTANT:** The Status LED will flash red and green, and the lock will beep. Press and release the Program button again.

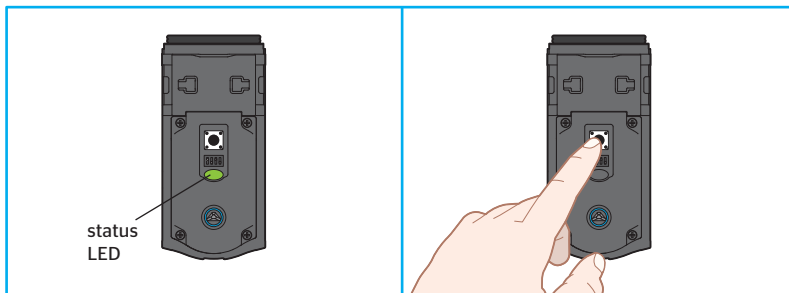

**D** The latch bolt will retract and extend on its own to learn the orientation of the door.

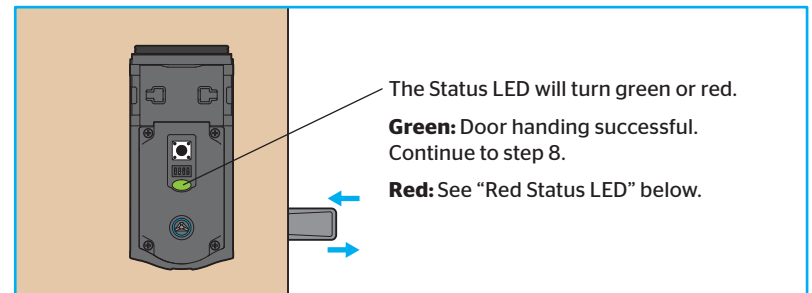

If the bolt does not move, make sure the batteries are installed correctly, and perform steps B-D again.

### Red Status LED

#### **BALDWIN ESTATE DEADBOLTS ONLY:**

If your latch bolt is to the **RIGHT** of your interior assembly, and the Status LED is solid red after door handing, **press and release the Program button again**. The door handing process will restart.

If you are unsure if your lock is Baldwin Estate, see chart on page 3 or compatible deadbolt list on page 11.

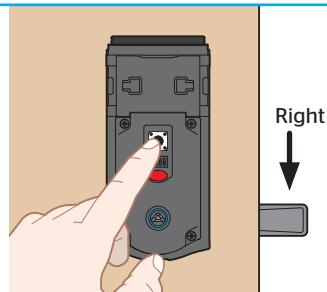

#### **OTHER DEADBOLTS:**

If the Status LED is solid red after door handing, make sure the batteries are installed correctly and the lock interior is correctly installed. Perform steps B-D again.



## 8 Download the Kevo app and set up your smartphone.

A Download the Kevo app at [kwikset.com/kevo/app](http://kwikset.com/kevo/app) or scan the QR code below.



B Follow the instructions inside the app to create an account, enroll your first smartphone and send eKeys to family and friends.



# 9

## Install the interior cover.

### Important information about the interior cover:

The interior cover will be secured by three screws to prevent someone from removing the battery or tampering with your lock's settings.

The window on the interior cover is locked by default.

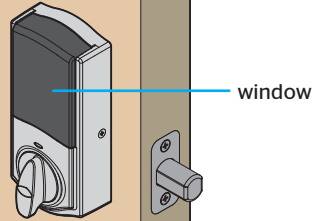

If the window is unlocked, it can slide up for more convenient access to programming buttons while the cover is installed.

Note: The interior cover and screws must be removed for battery pack access.

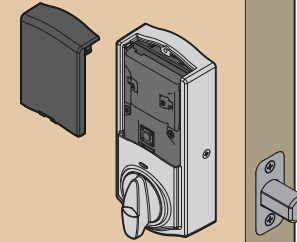

### If you want to keep the window locked:

**a** Install the cover.

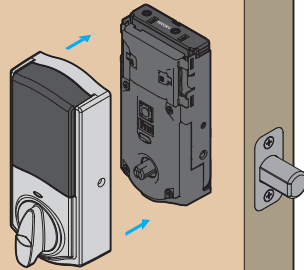

**b** Secure the cover with three (3) interior cover screws.

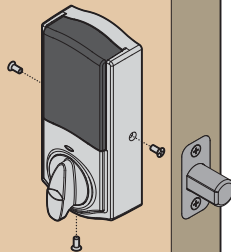

### If you want to unlock the window:

**a** Remove the security screw.

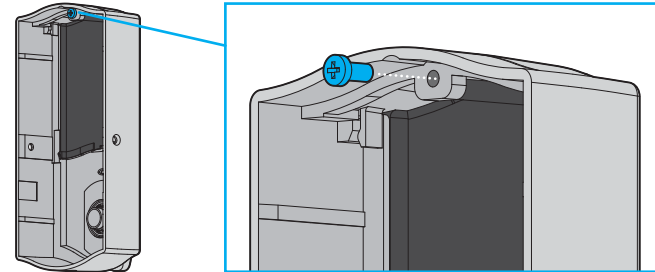

**b** Install the cover.

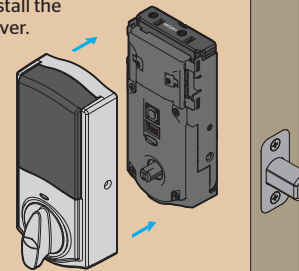

**c** Secure the cover with three (3) interior cover screws.

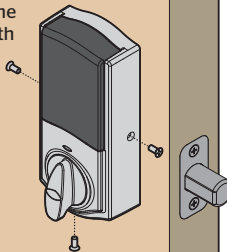

## Kevo Convert Compatibility Chart

Kevo Convert is compatible with the following models:

### Kwikset

#### Deadbolts

158  
660  
660M  
780  
816  
980  
980AUD  
993

#### Combo Packs

991

#### Handlesets

Amherst  
Arlington  
Ashfield  
Chelsea  
Austin  
Avalon  
Hawthorne  
Montara  
Shelburne  
Tavaris  
Wellington  
Bellevue  
Dakota

### Weiser

#### Deadbolts

GD9471  
GDC9471  
GCD9471  
GCD9571  
SSD9471  
9471-K3 (SQT)  
9471-K3 (RDT)

#### Door Handles

Acacia  
Amherst  
Ashfield  
Augusta  
Avalon  
Bingsley  
Brentridge  
Colonnade  
Columbia  
Davenport  
Grayson  
Hawthorne  
Heritage  
Longbourn  
Monaco  
Pemberly  
Tavaris  
Whistler  
Shelburne

### Baldwin Prestige

#### Deadbolts

380

#### Entrance

Avendale Alcott  
Avendale Carnaby  
Avendale Tobin  
Bighorn Handleset  
Medina Handleset  
Nautica Handleset  
Pistoria Handleset  
Segovia Handleset  
Spyglass Handleset  
Wesley Alcott  
Wesley Carnaby

### Baldwin Reserve

#### Deadbolts

All single cylinder deadbolts

#### Entrance

Adirondack Handleset  
Chesapeake Handleset  
Columbus Handleset  
Cottonwood Handleset  
Del Mar Handleset  
Elizabeth Handleset  
Elkhorn Handleset  
Fairbanks Handleset  
Kodiak Handleset  
La Jolla Handleset  
Longview Handleset  
Miami Handleset  
Napa Handleset  
New Hampshire Handleset  
Santa Cruz Handleset  
Seattle Handleset  
Westcliff Handleset

### Baldwin Estate

#### Deadbolts

8011  
8031  
8041  
8220  
8231  
8237  
8241  
8244  
8250  
8252  
8254  
8285

#### Entrance

*(Tubular products only)*

Bethpage Knob Sectional Trim  
Canterbury Knob Sectional Trim  
Canterbury Lever Sectional Trim  
Glennon Escutcheon Trim  
Logan Knob Sectional Trim  
Logan Lever Sectional Trim  
Logan Sectional Trim  
Madison Knob Sectional Trim  
Madison Lever Sectional Trim  
Minneapolis Sectional Trim  
Nantucket Escutcheon Trim  
Palm Springs Sectional  
Handleset  
Soho Sectional Trim

### Schlage

#### Deadbolts

B360N  
B560P  
B60N  
B660P6  
B760P

## Kevo Convert at a Glance

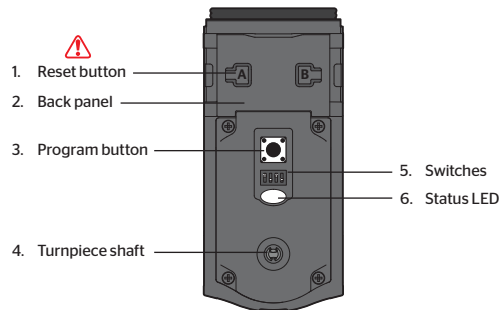

1. ⚠️ Only use to reset Kevo Convert to delete all eKeys from your system. See "System Reset" for more information.
2. Where all the programming features are located.
3. Use to enroll smartphones.
4. Engages with turnpiece when interior cover is installed. When the cover is removed, the turnpiece shaft can be used to manually lock and unlock the door.
5. Use to enable and disable the Status LED, Invert, Audio, and Auto-Lock.
6. Communicates whether the door is locked or unlocked and flashes red for a low battery alert. Can be turned on and off by Switch #1.

## Kevo-Compatible Devices

### Smartphones and Smart Devices

A Kevo-compatible smartphone (or other mobile internet-connected device or tablet) must have Bluetooth Smart Ready/ Bluetooth 4.0 and an app specific to the device must be installed. Find out if your device is compatible at [www.kwikset.com/kevo/devices](http://www.kwikset.com/kevo/devices).



### Standard Key

Always make sure you have access to your standard key.

## Switches

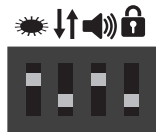

1 2 3 4



### Switch 1 Status LED

Door lock status LED blinks every 6 seconds. ON position is factory default.

### Switch 2 ⚠️ Invert

Only used for right-handed doors that have installed silver components. See page 6 for details.

### Switch 3 Audio

Beeping sound is heard during programming and normal operation. ON position is factory default.

### Switch 4 ⚠️ Auto-Lock

Automatically re-locks door 30 seconds after unlocking. OFF position is factory default.

⚠️ **CAUTION:** With this feature enabled, it is possible to lock yourself outside if you don't have an enrolled smartphone or standard key with you.

## Status LED Notifications

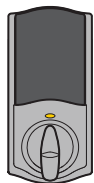

**Amber flash**  
Door is locked

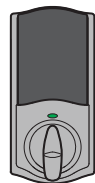

**Green flash**  
Door is unlocked.

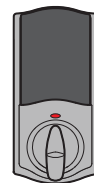

**Red flash**  
The 4 AA batteries in the Kevo interior are low and need to be replaced.

## System Reset

⚠️ **WARNING:** Resetting your Kevo system will restore your lock to factory settings and delete all smartphones from Kevo's memory.

If you wish to perform a system reset, **press and hold** the Reset button on the back panel for 10 seconds until the lock beeps.

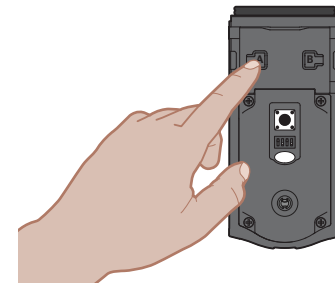

After a system reset, you will need to re-enroll your Owner phone. You will still be able to send eKeys at no charge to anyone who previously had an active eKey at the time of reset.

## Advanced Features

### History Log

A history of the lock's activity may be viewed through the Kevo app or by logging into the web portal: [www.mykevo.com](http://www.mykevo.com).

### Notifications

The Kevo app can send notifications when the door is locked and unlocked by eKey holders. You can choose to receive the system's default notifications or set up custom notifications to monitor a specific user or time frame.

### Dual Factor Authentication

Kevo features an optional, added-security passcode that you can enable inside the app to be used in addition to the app's password. Enabling the passcode will require you to enter a 4-digit PIN whenever you access the app, and it protects your Kevo account against unauthorized changes when your phone is unlocked.

### Kevo Plus

With Kevo Plus, you will be able to lock and unlock your home and check whether your door is locked or unlocked when you are away from home. You can upgrade to Kevo Plus inside the Kevo app. Visit [www.kwikset.com/kevo/kevo-plus](http://www.kwikset.com/kevo/kevo-plus) for more information.

### Connect Smart Products

Connect Kevo to select smart products. In the Kevo app, tap the gear icon to connect to smart products (iOS only: select "Preferences"). Visit [www.kwikset.com/kevo/support](http://www.kwikset.com/kevo/support) for more information.

## Important Safeguards

1. Read all instructions in their entirety.
2. Familiarize yourself with all warning and caution statements.
3. Remind all family members of safety precautions.
4. Always have access to your lock's standard key.
5. If using the Auto-Lock feature, make sure to have your smartphone or standard key with you to prevent locking yourself out.
6. Replace low batteries immediately.

### Preventing Inadvertent Unlocking of Your Door

 **WARNING:** Failure to follow these safeguards could result in your lock opening inadvertently.

1. Restrict access to your Kevo lock's back panel and routinely check your settings to ensure they have not been altered without your knowledge.
2. Protect the password to your Kevo app and web portal accounts.
3. When sending an eKey, always double-check that you are sending it to the correct recipient.
4. Protect and restrict access to your smartphone so that your app settings cannot be altered without your knowledge.
5. Enable the Kevo app's security passcode so that your app settings cannot be altered without your knowledge.
6. When sending eKeys, be aware of the difference between an Admin user and other users in the system: an Admin user can send, disable and delete eKeys.
7. If your smartphone is lost or stolen, use the Kevo web portal ([www.mykevo.com](http://www.mykevo.com)) to disable it.

 **WARNING:** This Manufacturer advises that no lock can provide complete security by itself. This lock may be defeated by forcible or technical means, or evaded by entry elsewhere on the property. No lock can substitute for caution, awareness of your environment, and common sense. Builder's hardware is available in multiple performance grades to suit the application. In order to enhance security and reduce risk, you should consult a qualified locksmith or other security professional.