



AQUATIC

*Where Inspiration Takes Shape*



SERENITY

## OWNER'S MANUAL & INSTALLATION GUIDE

**Installer:** This booklet must be given to the product owner. Please add important information below.

Model # \_\_\_\_\_ Purchase Date \_\_\_\_\_

Serial # \_\_\_\_\_ Distributor \_\_\_\_\_

**Note:** Read all instructions before proceeding with installation.  
All specifications are  $\pm 3/8''$  and are subject to change without notice. Dimensions listed in inches (mm).



## TABLE OF CONTENTS

PRODUCT WARRANTY REGISTRATION INFORMATION	3
IMPORTANT SAFETY INSTRUCTIONS	4 – 5
SERENITY AIR BATH USER INFORMATION	6
FCC INFORMATION	6
AQUATIC LIMITED WARRANTY	7
<b>INSTALLATION INSTRUCTIONS</b>	
Pre-Installation Procedures	8
Structural Preparation	9 – 11
Factory Installed Tile Flange	12
Fast-Fill Water Spout for Serenity 33	12
Plumbing	12
Electrical Installation	13
Electrical Connections	14 – 17
Variable Speed Air Blower Remote Mounting (Non-Freestanding)	18
Installation of Freestanding Models	19 – 22
Variable Speed Air Blower Remote Mounting (Freestanding)	23 – 24
Serenity 27 Installation	25 – 26
Remote Control (Non-Freestanding)	27 – 28
Remote Control (Freestanding)	29
Final System Test & Clean-Up	30
<b>OPERATION</b>	
Bathside Control Systems (Non-Freestanding)	31
Bathside Control Systems (Freestanding)	32
To Replace LED Light	33
<b>TUB CARE</b>	
Maintenance	34
Flushing/Sanitizing	34
Surface Scratch Removal	34
Repair	34
Water and Air Temperature	34
<b>Serenity 27 Copper Tub</b>	
Cleaning	35
Flushing/Sanitizing	35
Water and Air Temperature	35
<b>WATER QUALITY ISSUES</b>	
Chemical and Water Quality	36 – 37
<b>TROUBLESHOOTING GUIDE</b>	38
<b>REPLACEMENT PARTS LIST</b>	38
<b>REPLACEMENT PARTS MAP</b>	39

## AQUATIC

# Product Warranty Registration Information

Thank you for choosing an Aquatic bath. You have chosen one of the finest bath products in the industry! Aquatic supports your purchase with strong commitments to quality and customer satisfaction.

### IMPORTANT!

To activate Product Warranty please register with Aquatic. Your product warranty must be registered and confirmed with Aquatic through the Serial Number on your unit. To register, please contact Aquatic.

(800) 945-2726 • [www.aquaticbath.com/register](http://www.aquaticbath.com/register)

Please read and follow all of the instructions contained in this Owner's Manual before installing, operating or maintaining your air bath. In addition, you should continually refer to these instructions during the life of your air bath. Failure to comply with these instructions may invalidate your warranty. If you have any questions concerning installation, operation, maintenance or any other aspect of your Air Bath, please contact:

**AQUATIC CUSTOMER SERVICE CENTER: (800) 945-2726**

(The Troubleshooting Guide on page 38 may be helpful in answering some of your questions.)

**NOTE: The installation and service of your Air Bath should be performed ONLY by a qualified electrician and plumber.**

### IMPORTANT!

This product **MUST BE WATER-TESTED** and inspected prior to installation or warranty will be voided. See page 8 for instructions.

**PLEASE CHECK ENTIRE UNIT FOR ANY DAMAGE.**

If it appears damaged, contact your Aquatic Distributor immediately. Aquatic warranty does not cover damage that occurs in transit.

#### SERIAL NUMBER LOCATION

The tub model and serial numbers are located above the blower area on the backside of the drop-in models. Your installer should have a service access panel in this location. The numbers are located on the bottom of the tub on freestanding models. Look for a label which resembles the one on the right.



**AQUATIC**

*Where Inspiration Takes Shape*

8101 E. Kaiser Blvd., Suite 200 • Anaheim, CA 92808  
(800) 945-2726 • Fax (866) 544-5353  
[www.aquaticbath.com](http://www.aquaticbath.com)

# IMPORTANT SAFETY INSTRUCTIONS

**WARNING:** When using this unit, basic precautions should always be followed. Failure to follow these instructions could result in personal injury, electric shock, or fire.

## READ AND FOLLOW ALL INSTRUCTIONS:

- **WARNING:** Risk of lethal electric shock. To reduce risk of electric shock, connect only to circuits protected by a Ground-Fault Circuit Interrupter (GFCI) or Residual Current Device (RCD).
- **DANGER:** To reduce the risk of injury, do not permit children to use this unit unless they are closely supervised at all times.
- Use this unit only for its intended use as described in this manual. Do not use additional attachments and/or equipment not recommended by the manufacturer.
- Never drop or insert any object into any opening.
- The unit must be connected only to a supply circuit that is protected by a Ground-Fault Circuit Interrupter (GFCI). Such a GFCI should be provided by the installer and should be tested on a routine basis. To test the GFCI, push the test button. The GFCI should interrupt power. Push the reset button. Power should be restored. If the GFCI fails to operate in this manner, there is a ground current flowing, indicating the possibility of an electric shock. Do not use this unit. Disconnect the unit and have the problem corrected by a qualified service representative before using.
- To reduce the risk of injury, enter and exit the bath slowly.
- This product is intended for indoor use only. Installing this unit outdoors could cause personal injury and will void your warranty.

SAVE THESE INSTRUCTIONS.

**Your safety and the safety of others are very important.**

We have provided many important safety messages in this manual and on your appliance. Always read and obey all safety messages.



This is the safety alert symbol. This symbol alerts you to potential hazards that can kill or hurt you and others.

All safety messages will follow the safety alert symbol and either the word "DANGER" or "WARNING." These words mean:

**! DANGER**

You can be killed or seriously injured if you don't immediately follow instructions.

**! WARNING**

All safety messages will tell you what the potential hazard is, tell you how to reduce the chance of injury, and tell you what can happen if the instructions are not followed.

# IMPORTANT SAFETY INSTRUCTIONS

Before taking your first air bath, be sure you have performed the "Flushing/ Sanitizing." [See **TUB CARE** on page 34.] Be sure that you are familiar with all the controls and switches and that the unit is operating properly. [See **BATHSIDE CONTROL SYSTEMS** on page 31-32.]

1. The water in a bath tub should never exceed 40° C (104° F). Water temperature between 38° C (100° F) and 40° C (104° F) are considered safe for a healthy adult. Bathing time should be limited to approximately 30 minutes, followed by a shower to cool down. Longer exposure may result in hyperthermia. The symptoms of this condition are nausea, dizziness and fainting, which can be fatal. Lower water temperatures are recommended for extended use (exceeding 10-15 minutes) and for young children.
2. If you will not be operating the air bath system during your bath, you may fill the bathtub to any comfortable level. However, if you will operate the system, you must fill the bathtub with water to a minimum of 4" above air channel. This will assure proper operation of the system.
3. **A few important bathing "DON'T'S"-**

**DO NOT operate the air bath system if:**

- The bathtub isn't filled to required levels above air channels.
- You're pregnant (until you've consulted your doctor).
- You're taking medications or drugs that may make you drowsy.
- You're drinking any form of alcohol.
- You've just had a meal. Wait for 30 minutes after eating.
- There is a child in the bathtub who may be left unattended at any time. Never allow small children to remain unattended in any bathtub.
- There are any small objects in the bathtub. The air bath action can move small objects at high speeds, causing pain and possible injury.
- You're smoking. The heat of burning tobacco can damage the bathtub surface. Keep tobacco products and ashtrays away from the bathtub.
- You have problems with your immunity system (until you have consulted your doctor).
- Never operate electrical appliances (television, hair dryer, radio, telephone, etc.) inside or within five feet (5') of the bath.
- You are using additional attachments and/or equipment not recommended by the manufacturer.
- You have a medical history of heart disease, low or high blood pressure, circulatory system problems, or diabetes, consult with a physician before using an airbath.
- You are under the influence of drugs, anticoagulants, stimulants, antihistamines, vasoconstrictors, vasodilators, hypnotics, narcotics, or tranquilizers.

# SERENITY AIR BATHS USER INFORMATION

**PLEASE NOTE:** The air bath action may cause even small amounts of bubble bath or shampoo to foam excessively. Exercise moderation in experimenting with different soap products.

No servicing of this product should be done by the user. There are no user serviceable parts. All controls are located in the control recesses on the lip of the tub. These are the only controls that should be used by the consumer. Do not change or alter any of these controls under any circumstances.

Motors are self-lubricating - No lubrication required.

## FCC CONSUMER INFORMATION

Electrical installation information listed on page 13.

This equipment generates and uses radio frequency energy and if not installed and used properly, that is, in strict accordance with the manufacturers instruction, may cause interference to radio and television reception. It has been type tested and found to comply with the limits for a class B computing device in accordance with the specifications in subpart J of part 15 of the FCC rules, which are designed to provide reasonable protection against such interference in a residential installation. However, there is no guarantee that interference will not occur in a particular installation. If this equipment does cause interference, which can be determined by turning the equipment on and off, the user is encouraged to try to correct the interference by one or more of the following measures:

- Reorient the receiving antenna.
- Relocate the receiver with respect to the bath tub.
- Move the receiver away from the bath.
- Plug the receiver into a different outlet so that the receiver and bath are on different branch circuits.
- If necessary, the user should consult the dealer or an experienced radio/television technician for additional suggestions.
- The user may find the following booklet prepared by the FCC helpful: "How To Identify and Resolve Radio-TV Interference Problems." It is available from the U.S. Government Printing Office, Washington, DC 20402, Stock No., 004-000-00345-4.



# Aquatic Industries Limited Lifetime Warranty

FOR SERENITY SERIES  
Limited Warranty For Original Consumer For Household Usage

## WHAT PRODUCTS ARE COVERED

Structures and surface finishes, pumps and blowers on the Serenity Series.

### *Warranty Periods for Specific Components*

#### LIFETIME WARRANTY FOR AIR BATH SHELL

Aquatic extends to the original consumer purchaser of the acrylic, fiberglass reinforced shell, a non-transferable lifetime warranty that the shell will retain its structural integrity and configuration and be free of water loss due to a defect in the tub shell. The warranty covers the tub shell against defects in material or workmanship. This warranty does not apply to all other components (attachments to the acrylic, fiberglass reinforced shell, such as plumbing, fittings and other apparatus) because these pieces are covered below under a 2 Year Warranty.

#### LIFETIME SURFACE WARRANTY FOR FACE OF AIR BATHS

The interior surface is warranted against fading, blistering, cracking and delamination due to defects in the surface materials for life. This surface warranty extends to defects due to surface material mixing or molding. This surface warranty does not apply to fading, cracking, delamination or blistering due to excessive wear, sun fading or scouring due to cleaning.

#### 2 YEAR EQUIPMENT WARRANTY FOR SUPPORT EQUIPMENT, COMPONENTS, CONTROLS & PLUMBING EQUIPMENT

All support equipment, components, controls and plumbing equipment on Air Baths are warranted for 2 years from date of purchase, but not more than 3 years from date of manufacture, against defects in workmanship and materials. Fuses and pillows are not included in this limited warranty.

#### EXCLUSIVE REMEDY

Aquatic will, **at its option**, repair or replace (without removal or installation) the affected components of any defective Unit or System; repair or replace (without removal or installation) the entire defective Unit or System; or refund the then-current list price of the Air Bath. In all cases, a reasonable time period must be allowed for warranty repairs to be completed.

#### WHAT YOU MUST DO

In order to make a claim under these warranties:

1. You must be the original consumer purchaser of the Air Bath.
2. You must promptly notify us within the warranty period of any defect and provide us with any substantiation that we may reasonably request.  
Write to: **Aquatic 1521 N. Cooper, Suite 500, Arlington, TX. 76011.**
3. The tub must have been installed and maintained in accordance with good industry practice and the specific Aquatic directions contained in the Owner's Manual and Installation Guide. Write for one if you don't have one!

#### EXCLUSIONS

These warranties do not extend to or do not cover defects caused by:

1. Shipping damage by carriers or installation errors.
2. Accident, acts of God, abuse or misuse.
3. Unreasonable use (including any use for non-bathing purposes or failure to provide reasonable and necessary maintenance as specified in Aquatic Owner's Manual and Installation Guide supplied with the Air Bath).
4. Any alteration, customization, or modification of the Air Bath or its components.

#### LIMITATIONS

1. **Aquatic Air Baths sold for industrial, commercial or hotel use** are warranted for two years, but not more than 3 years from date of manufacture, with a limited warranty that the shell will retain its structural integrity and configuration and be free of water loss due to a defect in the tub and the interior surface/face of the Air Bath is warranted against fading, blistering, cracking and delamination due to defects in the surface materials. All support equipment, components, controls and plumbing equipment and limited labor on the support equipment, controls, or plumbing are warranted for 1 year, but not more than 2 years from date of manufacture. Pump seals, "O" rings, light bulbs, fuses and pillows are not included in this two-year period. However, these accessories are warranted to be free from defects in materials and workmanship at the time of delivery to the original purchaser.
2. **In all cases, Aquatic reserves the right to fully satisfy its obligations under the Limited Warranties by refunding the then-current list price of the defective Tub (or, if the Tub has been discontinued, of the most nearly comparable current product).**
3. Aquatic reserves the right to furnish a substitute or replacement component or product in the event a Tub or any component of these products is discontinued or otherwise unavailable.
4. **THESE WARRANTIES ARE NON-TRANSFERABLE TO ANY OTHER PURCHASER OR PARTY OTHER THAN THE ORIGINAL CONSUMER. NO OTHER AGENT OR PARTY CAN GIVE ANY OTHER WARRANTY OR PROMISE. THIS IS THE SOLE WARRANTY FOR YOUR Aquatic PRODUCT.**
5. Aquatic will not cover any installation or reinstallation costs related to this warranty, except under the limited labor allowance under the 2 Year Equipment Warranty above.
6. **Your warranty period starts** (begins to run) at the earlier of 1) the beginning of installation of your Air Bath in a home, or 2) the purchase of your Air Bath, and shall never exceed 8 years from the date the Air Bath is manufactured for its shell or finish, or 3 years from the manufacture of plumbing supplies and accessories.
7. For indoor use only. Installing Air Bath or any of its components outdoors will void your warranty.

#### GENERAL

This warranty gives you specific legal rights; you may also have other rights, which vary from state to state. THE DURATION OF ANY IMPLIED WARRANTIES, INCLUDING THE IMPLIED WARRANTIES OF MERCHANTABILITY AND FITNESS FOR A PARTICULAR PURPOSE, ARE LIMITED TO THE DURATION OF THE EXPRESS WARRANTIES HEREIN. Aquatic EXPRESSLY EXCLUDES INCIDENTAL AND CONSEQUENTIAL DAMAGES, TO INCLUDE LOSS OF TIME, INCONVENIENCE, OR LOSS OF USE OF RESIDENCE, FOR ANY BREACH OF THE EXPRESS OR IMPLIED WARRANTY, INCLUDING THE IMPLIED WARRANTIES OF MERCHANTABILITY OR FITNESS FOR A PARTICULAR PURPOSE.

SOME STATES DO NOT ALLOW ANY LIMITATION ON HOW LONG AN IMPLIED WARRANTY LASTS, OR THE EXCLUSION OR LIMITATION OF INCIDENTAL OR CONSEQUENTIAL DAMAGES; SO THE ABOVE EXCLUSION MAY NOT APPLY TO YOU.

# INSTALLATION INSTRUCTIONS

## READ ALL INSTRUCTIONS CAREFULLY BEFORE INSTALLATION

### PRE-INSTALLATION PROCEDURES

**PLEASE NOTE:** THE MANUFACTURER ACCEPTS A  $\pm 3/8"$  VARIANCE. THERE ARE VARIATIONS ON EACH TUB AND SPECIFICATIONS ARE SUBJECT TO CHANGE AS WE IMPROVE UPON OUR PRODUCT AS REQUIRED.

THE DIMENSIONS NEEDED FOR SITE PREPARATION AND STRUCTURE BUILDINGS SHOULD BE MEASURED FROM THE TUB; AQUATIC ASSUMES NO RESPONSIBILITY FOR PREPARATORY WORK.

Note: A good knowledge of construction techniques, plumbing and electrical installation according to codes are required for proper installation. We recommend that a qualified licensed contractor perform the installation of all Aquatic products. Our warranty does not cover improper installation problems.

1. Immediately upon receiving your Aquatic bath, inspect it thoroughly for freight damage. If necessary, contact your distributor immediately (your distributor must contact Aquatic within 24 hours of receiving unit to file a claim). Should inspection indicate any damage, do not install the bath.
2. All baths are filled with water and operated in our manufacturing facility prior to shipment. Inspectors ensure watertight operation, however, rough handling may cause leaks which may be detected prior to installation.

Damage or defect to the finish claimed after the bath is installed is not covered under the warranty.

### TO INSPECT:

1. Place the tub in an area where it may be drained after testing.
2. Fill the tub to the overflow and allow to stand for a few minutes. Carefully inspect all fittings and connections for leaks.
3. Plug in blower control box and run blower for 10 minutes.
4. Inspect the tub completely. Any defect must be reported to Aquatic prior to installation in order to have it covered by warranty. Should inspection indicate any damage or leaks, do not install the bath.
5. Check to ensure that your installation will conform to all applicable codes and secure necessary permits. All electrical and plumbing connections should be made by qualified electricians and plumbers.

Damage or leaks claimed after the bath is installed are not covered under the warranty.

### **WARNING: FAILURE TO FOLLOW THESE INSTRUCTIONS DURING INSTALLATION WILL RESULT IN TERMINATION OF THE WARRANTY:**

Do not lift the tub by any portion of the plumbing or blower.  
Do not stand in the tub during construction.

DO NOT MAKE ANY ALTERATIONS, ADDITIONS, OR DELETIONS TO THE  
AIR BATH SYSTEM BLOWER OR BATH.

### QUIETNESS OF OPERATION

Aquatic has engineered their air baths from base to lip to ensure quality, value, functional design, and maximum bathing comfort. However, installation is accountable for as much as 50% of a tub's operating quietness. Please ensure the following:

- The floor structure is adequate to support the installation.
- For quieter operation and heat retention conservation, the walls surrounding the air bath may be insulated.\*
- Insulate the tub surround.\* Do not allow any insulation to come within 3 feet of the blower. The area around the blower must be clean and free of any foreign matter.
- Leave 1/8" to 3/16" gap between tub lip and surround.\*
- Spread a bed of cement mortar on the floor or subfloor under the air bath to reduce vibration and noise.\*

*\*Not required on freestanding models.*



# INSTALLATION INSTRUCTIONS

## READ ALL INSTRUCTIONS CAREFULLY BEFORE INSTALLATION

### STRUCTURAL PREPARATION

**NOTE:** The bath should remain in its shipping carton until time of installation.

- Literature dimensions are for reference only. Installation dimensions should be taken directly from the tub. An unobstructed access panel of 16" x 16" minimum must be provided at the blower end of the air bath allowing sufficient clearance to make final connections and for servicing the blower and power panel. Access may be through the wall or platform apron at the end of the unit. In the case of sunken installations, access should be made through the ceiling below. A minimum ventilation opening of 2" x 4" for the blower is required and should be designed to draw in ambient air at a minimum of 72° F.

**It is the installer's responsibility to provide sufficient service access. Make absolutely certain that access panels and/or service openings are properly placed and that all possible areas where service may be required are accessible.**

- Install the drain fitting to the bath. THE DRAIN FITTING WILL PROTRUDE BELOW THE BASE OF THE TUB APPROXIMATELY 1 1/2". Clearance may be needed for the drain by cutting away the subfloor (where possible) or by blocking below the tub as may be required. **WARNING: FACTORY SKIRTS DO NOT ALLOW FOR BLOCKING UP OF THE TUB BASE.** All blocking must be solid and provide uniform support to the tub base.

**NOTE:** Watertight installation of the drain and overflow is the installer's responsibility. Drain and/or overflow leakage is not included in the warranty of this product.

- Tub must rest entirely on its base. **DO NOT SUPPORT THE BASE OF THE TUB BY THE RIM.** Aquatic strongly recommends preparing a bed of wet mortar in the area where tub is to be installed to assist in leveling and reduce vibration noise. Carefully level unit, ensuring that uniform support is given to all areas of the base and no portion of the lip is bearing weight.
- Frame out under the tub rim as shown in one of the illustrations (See diagram 1A-1D). **NOTE:** Due to the variety of installations possible, framing procedures other than those described may be required. Level in selected location. Level front to back and across both sides. A ledge under the rim, or an apron without a ledge, may be constructed as required (see Diagrams 1A and 1B). Where installation will be against a wall, stud wall framing should allow for wall sheathing material to run full length to the floor (see Diagram 1C). Install tub firmly against sheathing as indicated, with blocking below rim to prevent deflection or movement of tub. To prevent a rocking movement of tub after installation, it is important to have rim in contact, but not supported by blocking material.

- When placing the tub on a platform or cut out (see Diagrams 1A and 1D), the opening should be 1" smaller than the specified rim dimensions. Extreme care must be taken in this type of installation to ensure the tub will come to rest entirely on the base.

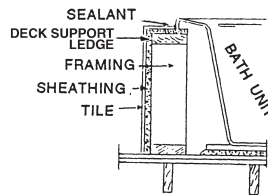

1A LEDGE INSTALLATION

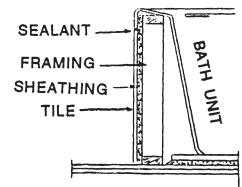

1B APRON INSTALLATION

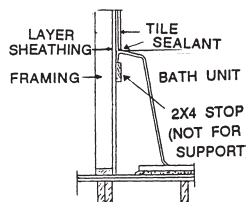

1C WALL INSTALLATION

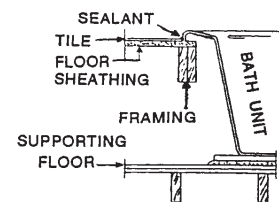

1D SUNKEN INSTALLATION

**WARNING:** ALL ELECTRICAL CONNECTIONS SHOULD BE MADE BY A LOCALLY LICENSED ELECTRICIAN.

- Another installation option is that of a tile flange. Aquatic offers an optional factory installed tile flange for all rectangular and corner-unit air baths.

*Note: The above illustration does not apply to freestanding models.*

# INSTALLATION INSTRUCTIONS

## STRUCTURAL PREPARATION (CONT.)

1. Protect interior of tub throughout installation process.
2. Framing and supports will vary according to the model and type of installation selected.

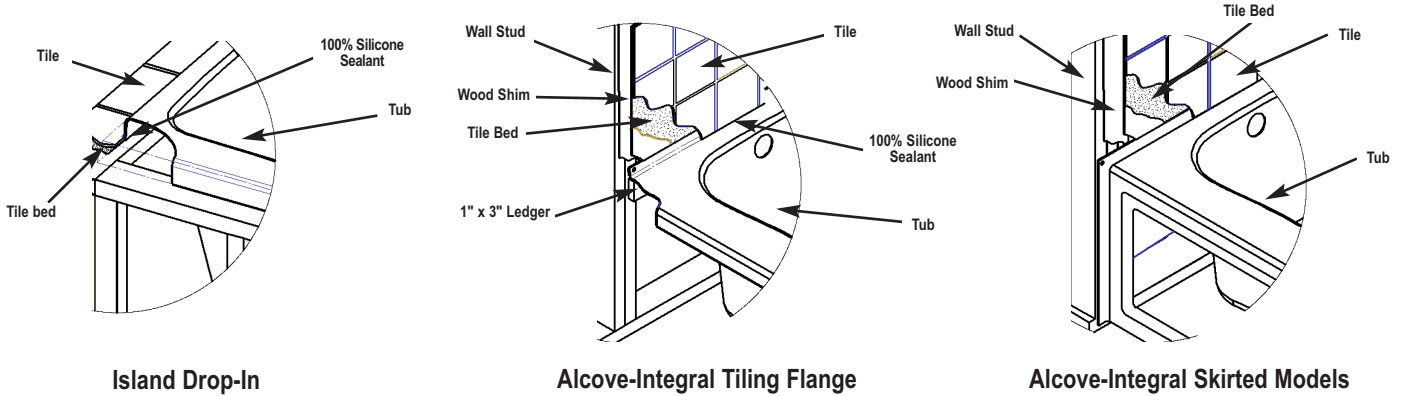

### ALCOVES

### ISLANDS

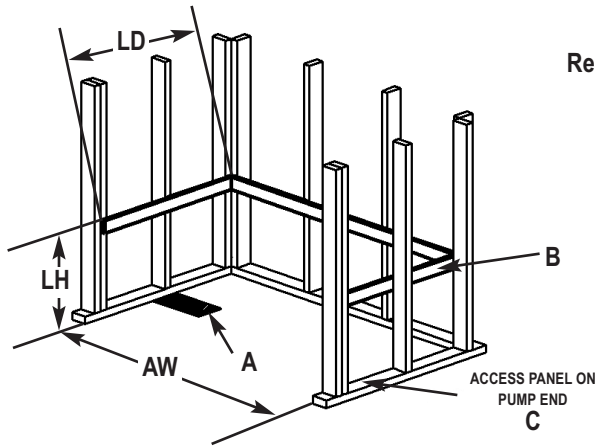

Rectangular Models

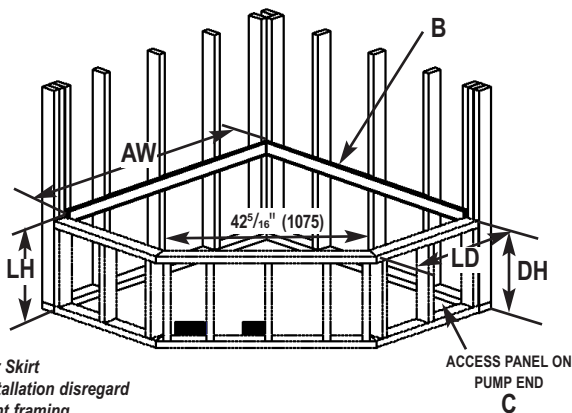
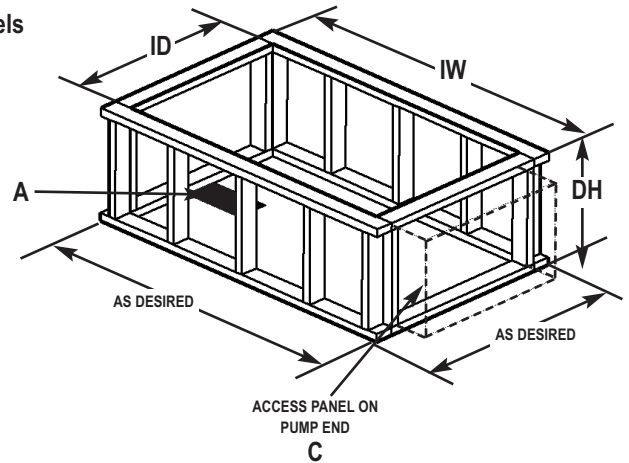

Corner Models

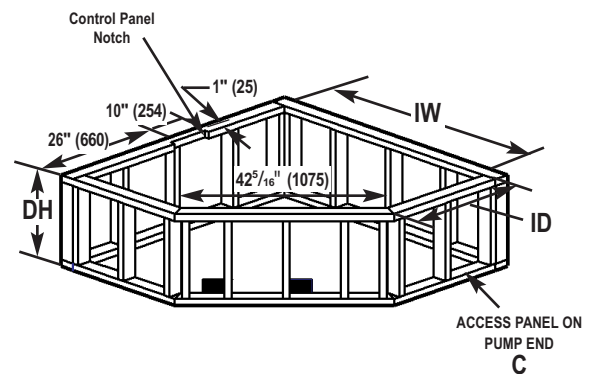

Note: For Skirt Installation disregard front framing

# INSTALLATION INSTRUCTIONS

## STRUCTURAL PREPARATION (CONT.)

### ALCOVES

### ISLANDS

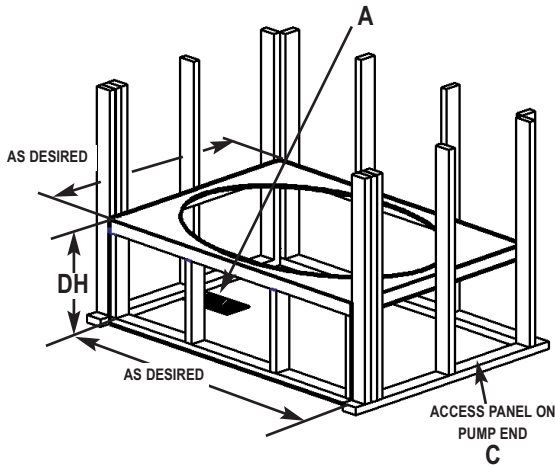

### Oval Models

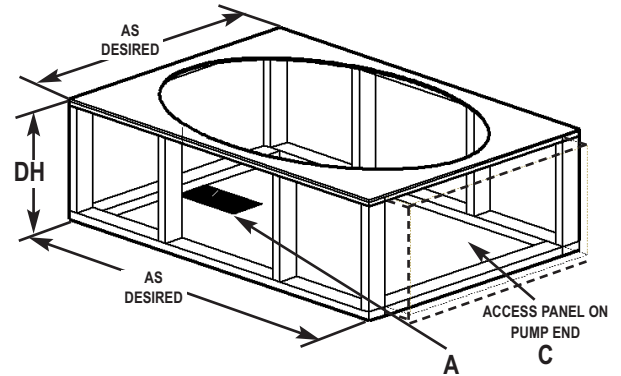

### Integrally Skirted Models

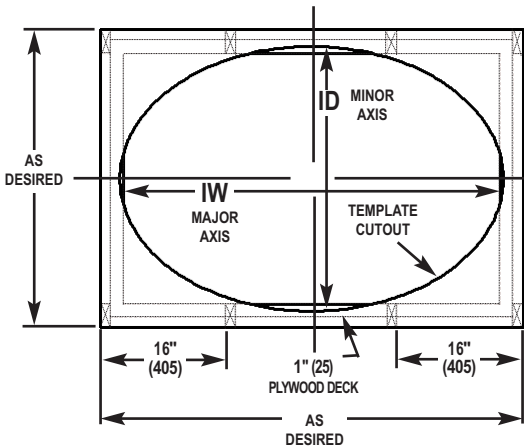

**DECK CUTOUT** - A paper template will be enclosed with all oval models. For the deck cutout, scribe on the deck two center lines (a major and minor axis). Next, match the center lines and trace the ellipse. Repeat this step three more times. Once the tracing is complete, cut out the ellipse. The dimensions should be exactly 2" (50) smaller than the unit.

- A - 6" x 12" (150 x 305) Box-outs
- B - Leveled Supports
- 1" x 3" (25 x 75) Ledgers
- C - 12" x 18" (305 x 460) minimum access

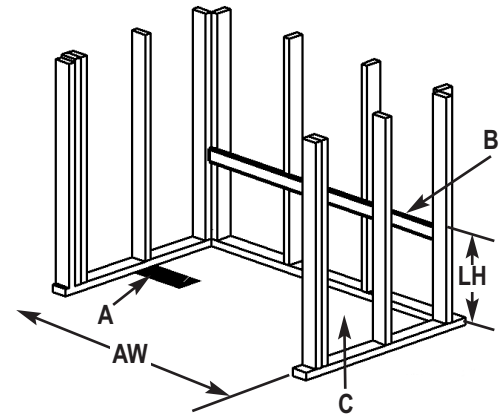

# INSTALLATION INSTRUCTIONS

## FACTORY INSTALLED TILE FLANGE

1. Install the air bath unit per the instructions provided in this manual. **CAUTION: THE TILE FLANGE DOES NOT SUPPORT THE TUB!** A ledger board must be provided under the bath rim as indicated in the installation instructions. Take care to ensure tub is not hanging from the ledger boards, as this will void your warranty.

2. Use nails or screws to secure the flange into the studs around the bath.

3. Install water resistant drywall against the tile flange and flush to the top of the air bath deck. Install the tile or other finishing materials. Apply a second bead of silicone between the first course of tile and the bath deck.

**NOTE:** Before tub is used, the air bath system should be cleaned in accordance with the procedures on Page 34 of this manual.

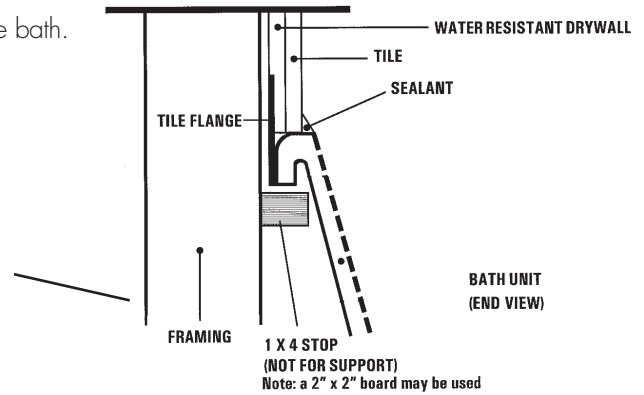

## FAST FILL WATER SPOUT FOR SERENITY 33

Your Fast Fill waterfall spout is stubbed out with a 3/4" female threaded brass fitting.

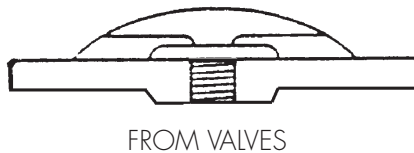

For connecting the hot and cold valves see image at right.  
**CAUTION:** Do not overtighten. Do not use Teflon Tape.

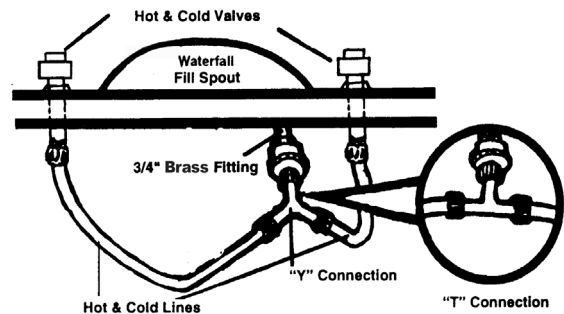

## PLUMBING

1. After securing tub in place, normal waste and overflow, water spout and valves are installed per normal plumbing procedures, in accordance with all state and local standards.
2. Install standard 1-1/2" trap to drain and overflow. Before proceeding, make final operational check by filling tub with water to overflow and operate blower for 5 minutes. Carefully check for leaks both while blower is running and after it has been turned off. Allow water to stand in tub for at least 30 minutes before draining. **AQUATIC WILL NOT BE RESPONSIBLE FOR WATER DAMAGE OF ANY KIND.**
3. When selecting fill spout location, check to ensure that spout is long enough to clear the tub rim from its desired location. If installation is to be on the tub deck, check the back side of tub for adequate space for connection to water lines and that there are no air channels running under that area of the tub rim before drilling or cutting tub.
4. A service access panel of a minimum of a 16" square must be provided adjacent to blower and control box assembly.

**Note:** For rough-in measurements please refer to the unit's technical data sheet.

# INSTALLATION INSTRUCTIONS

## ALL MODELS

### ELECTRICAL INSTALLATION

**WARNING:** ALL ELECTRICAL CONNECTIONS SHOULD BE MADE BY A LICENSED, LOCALLY CERTIFIED ELECTRICIAN, IN ACCORDANCE WITH THE REQUIREMENTS OF THE NATIONAL ELECTRICAL CODES AND PROCEDURES.

**WARNING:** WHEN USING ELECTRICAL PRODUCTS, PRECAUTIONS SHOULD ALWAYS BE FOLLOWED, INCLUDING THE FOLLOWING:

**DANGER:** RISK OF ELECTRIC SHOCK! This unit requires one dedicated circuit, protected by a Ground Fault Circuit Interrupter (GFCI). Rough in wiring to control box on a dedicated 120V, 15 amp, GFCI protected circuit.

GFCI's are not supplied, however we do specify their use.  
All known code authorities require GFCIs.

**ELECTRICAL:** A GFCI protected, 120 Volt, 15 Amp, 60 HZ circuit with a service ground is required, "dedicated" only to powering the bath.

**PLEASE NOTE:** Because the blower is housed in a plastic non-conductive housing, the blower does not need to be grounded.

**DANGER:** Risk of electric shock. Do not alter the factory installed wiring. A licensed electrician must provide the "dedicated" electrical service protected by a GFCI. The location of the GFCI must be accessible for regular testing.  
**USE COPPER CONDUCTORS ONLY.**

**CAUTION:** Before use of the blower, test the GFCI for proper operation. The blower should turn off when the GFCI "Test" button is pushed.

**WARNING:** Prolonged Immersions in Hotter Water May Induce Hyperthermia. Hyperthermia occurs when the internal temperature of the body reaches a level several degrees above the normal body temperature of 98.6°F. The symptoms of hyperthermia include an increase in the internal temperature of the body, dizziness, lethargy, drowsiness, and fainting. The effects of hyperthermia include (1) failure to perceive heat, (2) failure to recognize the need to exit the air bath, (3) unawareness of impending hazard, (4) fetal damage in pregnant women, (5) physical inability to exit the air bath, (6) unconsciousness resulting in the danger of drowning.

**WARNING:** The use of alcohol, drugs, or medication can greatly increase the risk of fatal hyperthermia.

# INSTALLATION INSTRUCTIONS

## NON-FREESTANDING MODELS

### ELECTRICAL CONNECTIONS

#### Serenity Air Series Component Breakdown

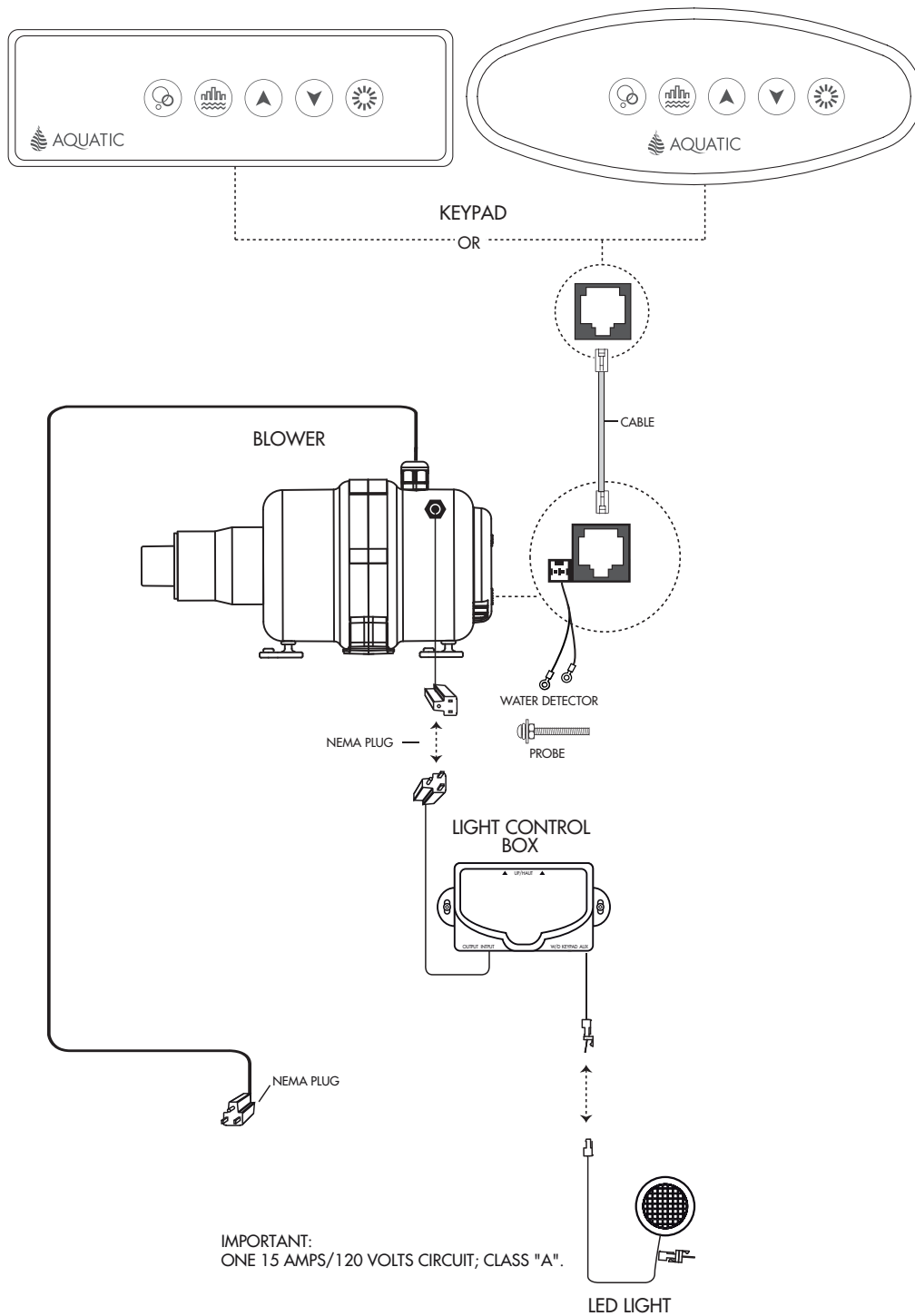

# INSTALLATION INSTRUCTIONS

NON-FREESTANDING MODELS

## ELECTRICAL CONNECTIONS

### Serenity Air Series Remote Blower Option Component Breakdown

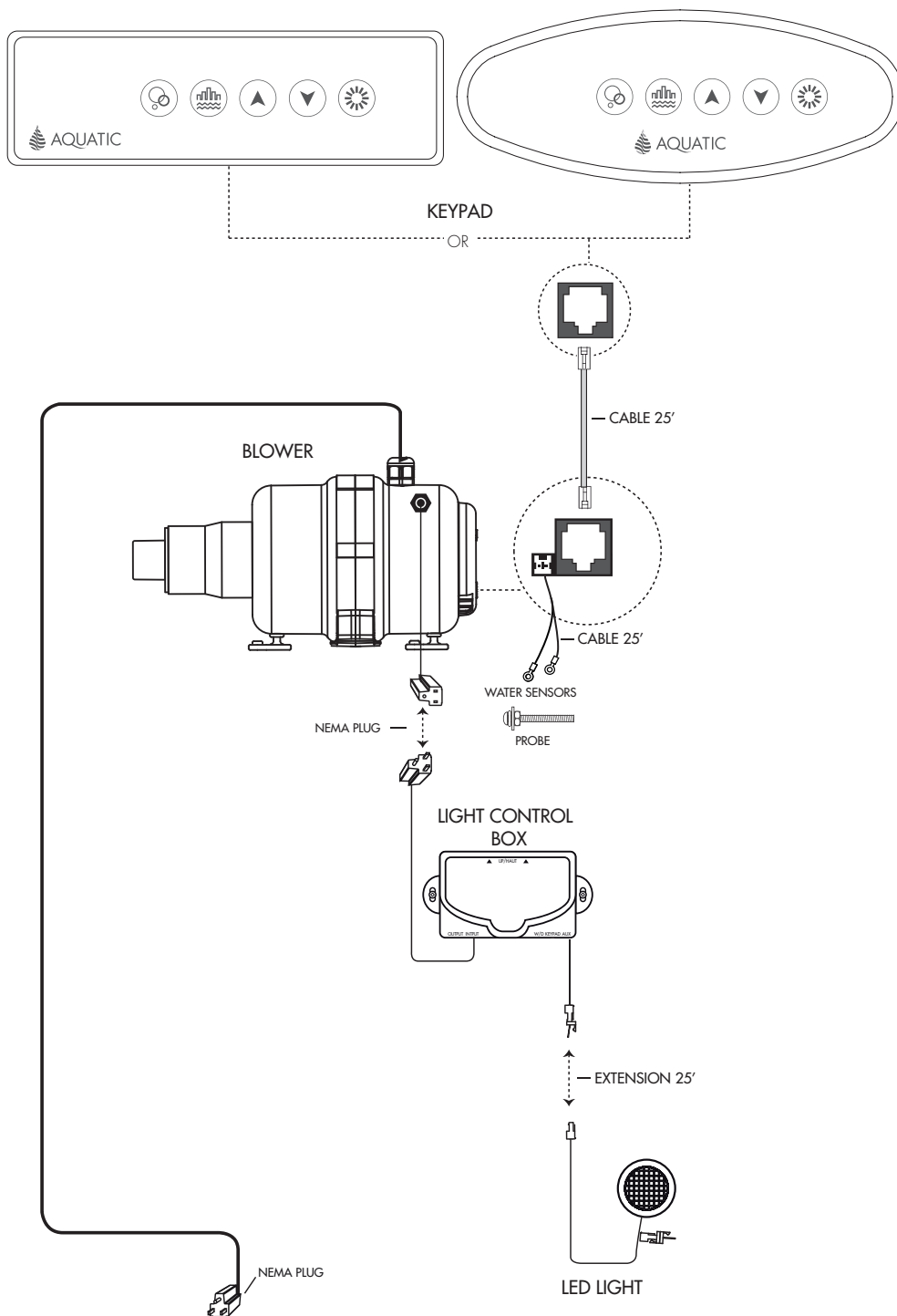

**IMPORTANT:**  
ONE 15 AMPS/120 VOLTS CIRCUIT; CLASS "A".

# INSTALLATION INSTRUCTIONS

## NON-FREESTANDING MODELS

### ELECTRICAL CONNECTIONS

#### Serenity Air Series Remote Option Component Breakdown

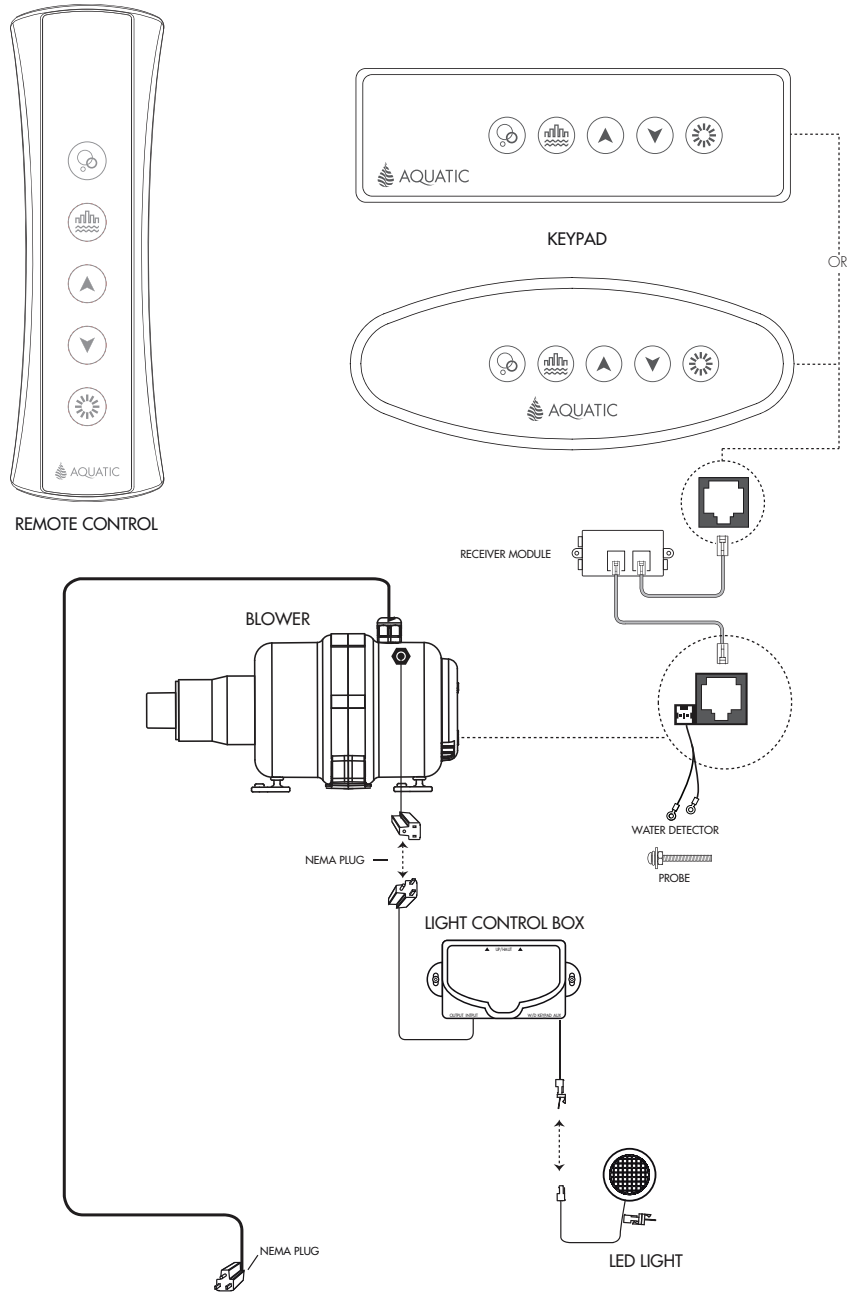

**IMPORTANT:**  
ONE 1.5 AMP/120 VOLTS CIRCUIT; CLASS "A".



# INSTALLATION INSTRUCTIONS

FREESTANDING MODELS

## ELECTRICAL CONNECTIONS

### Serenity Air Series Freestanding Component Breakdown

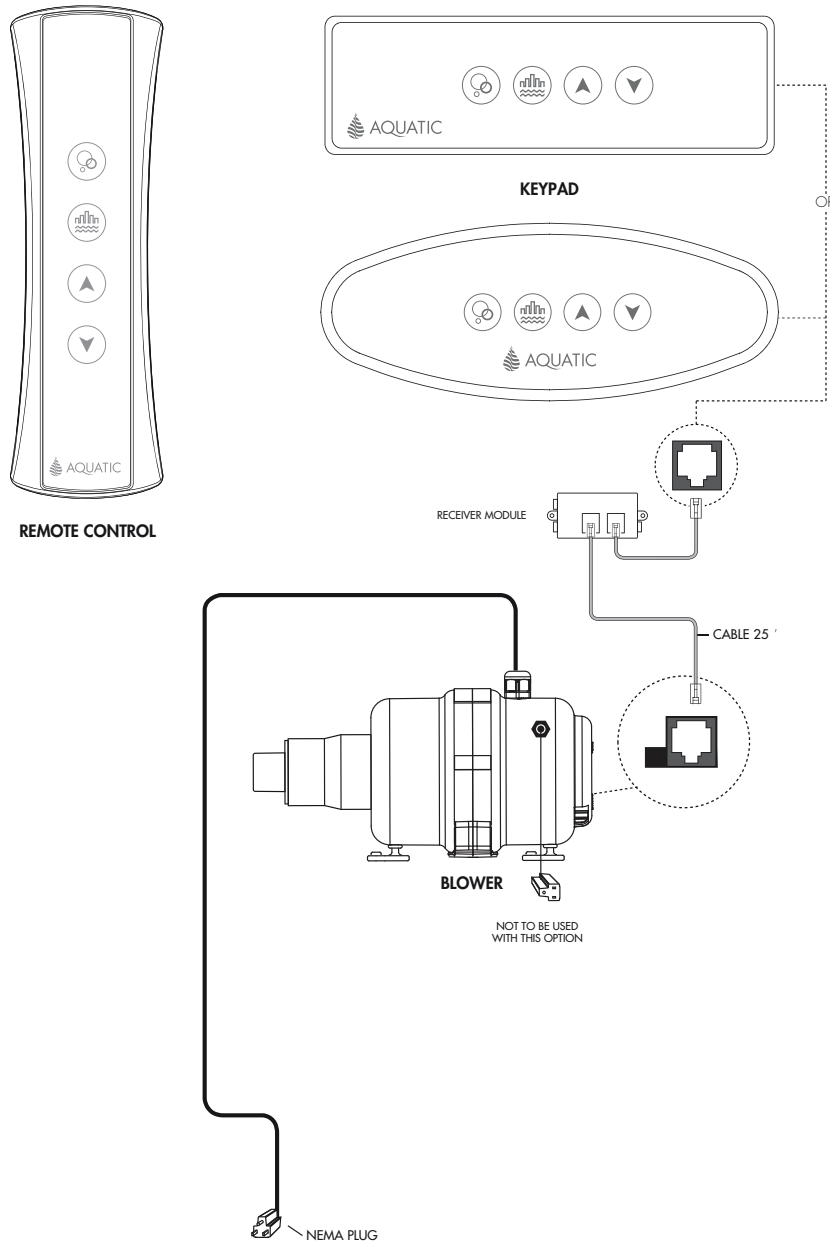

**IMPORTANT:**  
ONE 15 AMP/120 VOLTS CIRCUIT; CLASS "A".

# INSTALLATION INSTRUCTIONS

## NON-FREESTANDING MODELS

### VARIABLE SPEED AIR BLOWER REMOTE MOUNTING All models except freestanding models

#### Designating a Remote Location

The designated location for the blower must not exceed more than 15 feet of pipe and 6 directional changes. Choose a place as close to the bath as possible to make sure that the system works properly. The chosen place must not be cluttered and/or dusty and must allow for sufficient air circulation. The blower measures 7" W x 11" L x 6 1/2" H. This space must not be smaller than 4 cubic feet and must have a ventilation opening not smaller than 2" x 4". The air around the blower should be approximately 72°F (20°C) or higher for optimal performance.

- The blower and light control box must be accessible at all times.
- The extension cords must be able to reach the light control box and be routed per local code requirements.

#### Installing the Blower in a Remote Location

The blower can be installed horizontally or vertically. The blower intake maybe installed up or down. Use PVC 1 1/2" pipe and adapters only. Whenever possible, use two 45° elbows instead of one 90° elbow to change the direction of your pipe. Glue all pipe connections along the extension you have added. But DO NOT glue the pipe going into the blower; use the screw you removed when the blower was removed.

- The blower should be 6" off the floor or from the ceiling and the air intake end of the blower should be at least 4" from any walls or joists.
- To reduce heat loss, insulate the pipe.

Mount the Light Control Box close to the blower and the AC outlet. Plug in the key pad cable, blower cable, water level sensor cable and attach the Chromatherapy LED light wires. (See image below.) Now plug into a minimum 15 amp, 120V vac that is GFCI protected.

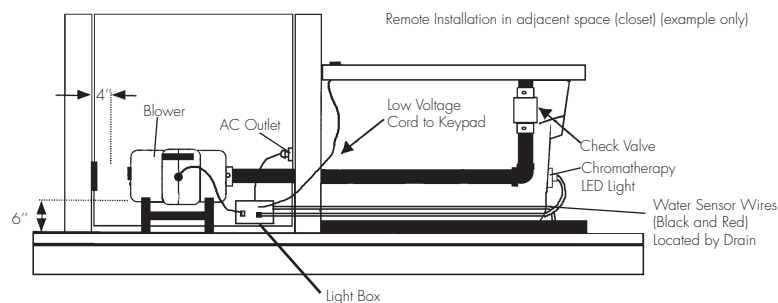

# INSTALLATION INSTRUCTIONS

## FREESTANDING MODELS

### INSTALLATION OF FREESTANDING MODELS

**NOTE:**

- Freestanding units must be placed on a perfectly leveled floor.
- The blower must be mounted in a remote location and cannot be installed on the bath.
- Wall mounted or freestanding faucets must be used.

### Serenity 10 & 37 Installation

For information on electrical installation, maintenance and care, troubleshooting and warranty, please refer to the Table of Contents.

Before the floor installation is complete, make sure it is perfectly level. Once the floor installation is complete, determine the exact location of the bath and mark the floor position of the four claw feet (see Diagram 2A). To help prevent the bathtub from shifting, we recommend the bathtub legs to be anchored to the floor. Also, mark the position of the holes to be drilled for the blower air passage and drain.

1. Drill a 2" hole for the air passage and 2" hole for the drain.
2. Install the drain and overflow on the bath. Cut pipes to desired length prior to assembly. Next, glue the first section of pipe (PVC 1 1/2") to the air passage under the tub and then cover the pipe with the pipe concealer (see Diagram 2B).

Diagram 2A

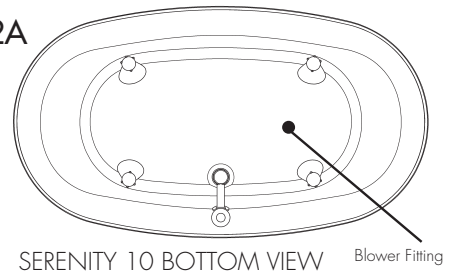

SERENITY 10 BOTTOM VIEW

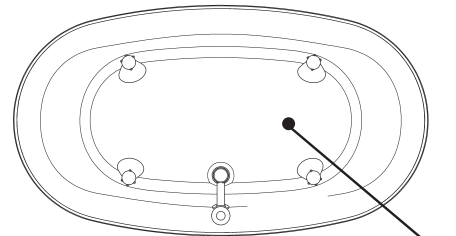

SERENITY 37 BOTTOM VIEW

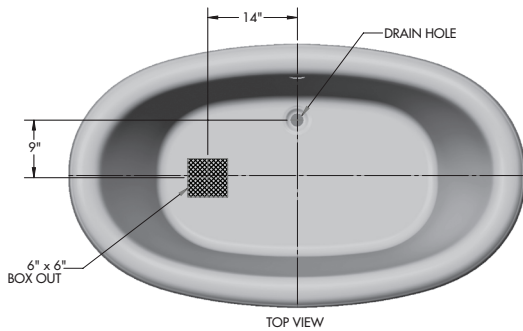

SERENITY 10 TOP VIEW

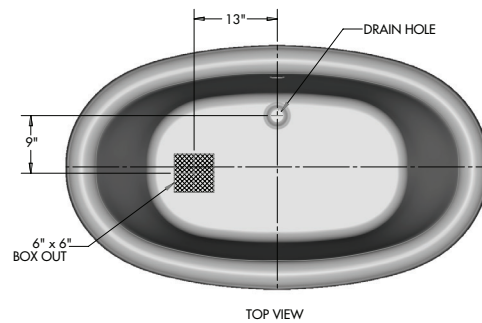

SERENITY 37 TOP VIEW

Diagram 2B

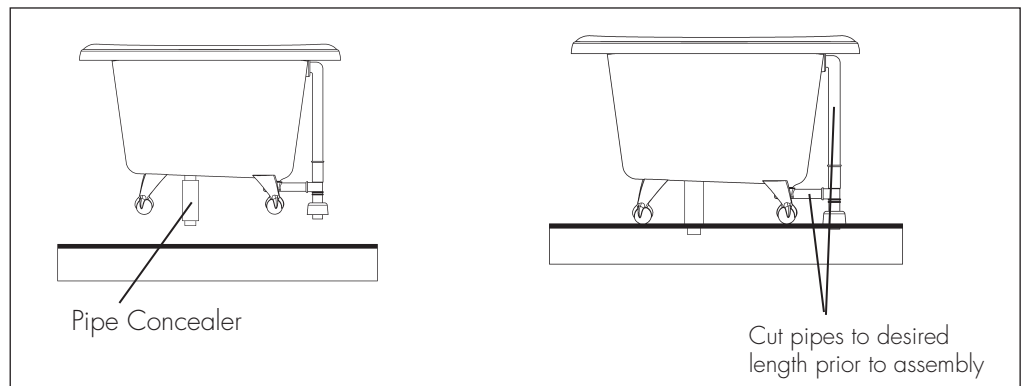

# INSTALLATION INSTRUCTIONS

## FREESTANDING MODELS

### Serenity 11 & 13 Installation

Before the floor installation is complete, make sure the floor is level. Once the floor installation is complete, determine the exact location of the bath and trace the contour of the bath with an erasable marker pen. **NOTE:** You will need to remove the wooden base attached to the bottom of the unit for shipping.

For information on electrical installation, maintenance and care, troubleshooting and warranty, please refer to the Table of Contents.

1. Determine the exact location of the drain, air passage and the two anchoring points at each end of the bath (see Diagram 3A).
2. To prevent the bath from moving sideways, secure the two anchoring pins (3/8" x 3" lag bolts, not supplied) to the floor. Leave the lag bolts 1 1/2" above floor. Wipe off the marker tracings (see Diagram 3B).
3. Install the overflow and drain on the bath. Cut pipes to desired length prior to assembly. Glue the first pipe section (PVC 1 1/2") of the air passage to go under the floor and make sure pins are lined up with holes in tub. Apply a silicone seal under the rim of the base and lay the bath down putting the pipes through the floor (see Diagrams 3C and 3D). Immediately remove any excess silicone. Also see Top Views Diagram 3E.

3A

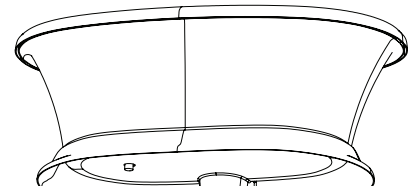

SERENITY 11 BOTTOM VIEW

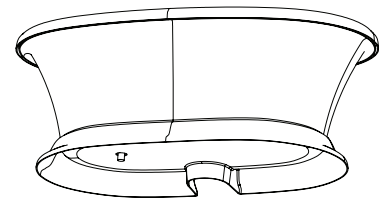

SERENITY 13 BOTTOM VIEW

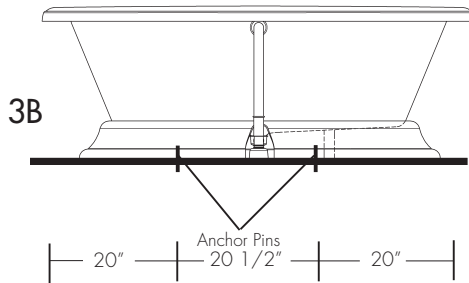

SERENITY 11 SIDE VIEW

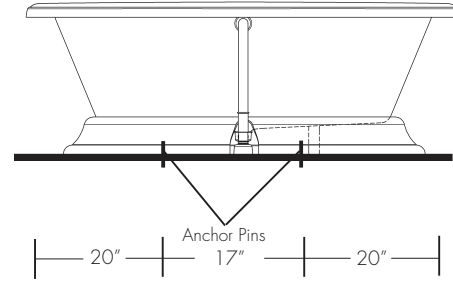

SERENITY 13 SIDE VIEW

Cut pipes to desired length prior to assembly

3C

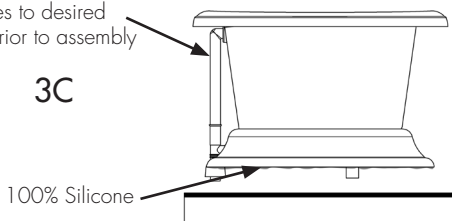

100% Silicone

3D

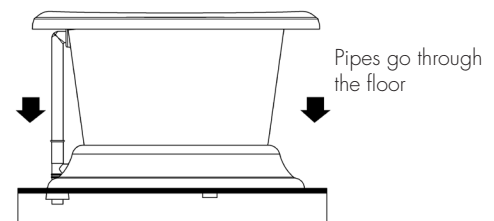

Pipes go through the floor

3E

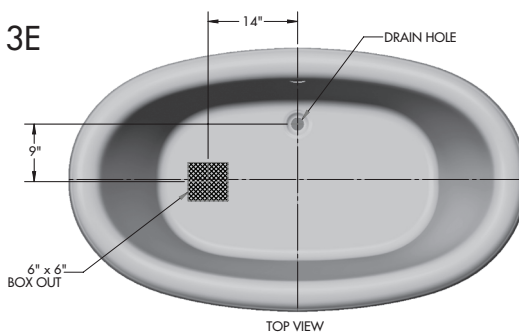

TOP VIEW

SERENITY 11 TOP VIEW

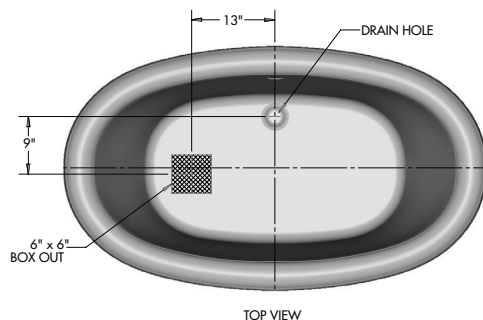

TOP VIEW

SERENITY 13 TOP VIEW

# INSTALLATION INSTRUCTIONS

## FREESTANDING MODELS

### Serenity 17, 23, 24, 25 and 26 Installation

Before installation is complete, make sure the floor is level. After that, determine the exact location of the bath and trace the contour of the bath with an erasable marker pen.

For information on electrical installation, maintenance and care, troubleshooting and warranty, please refer to the Table of Contents.

1. Determine the exact location of the drain, air passage and the two anchoring points at each end of the bath (see following diagrams).

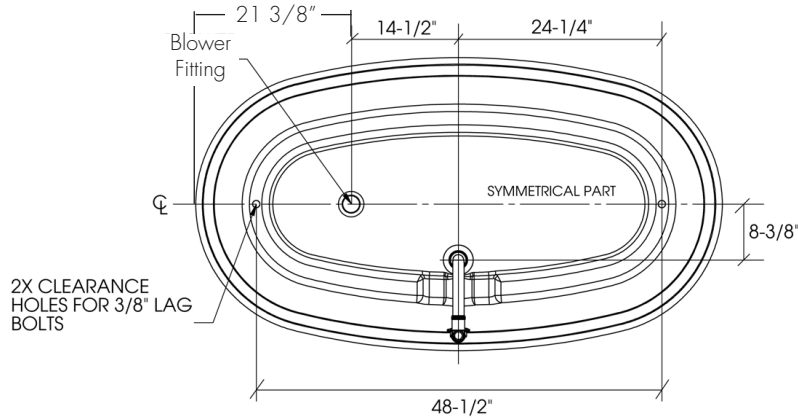

Serenity 17

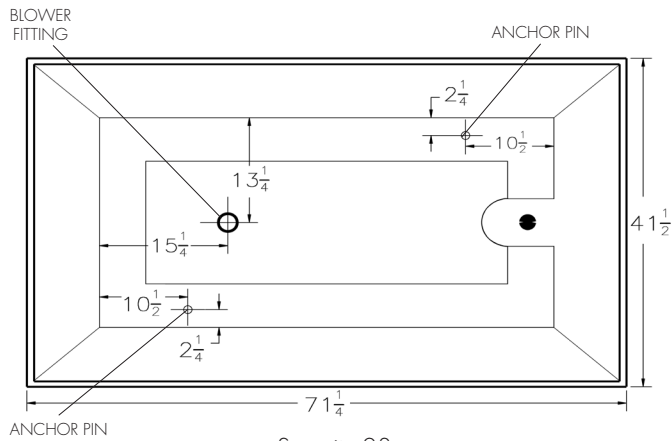

Serenity 23

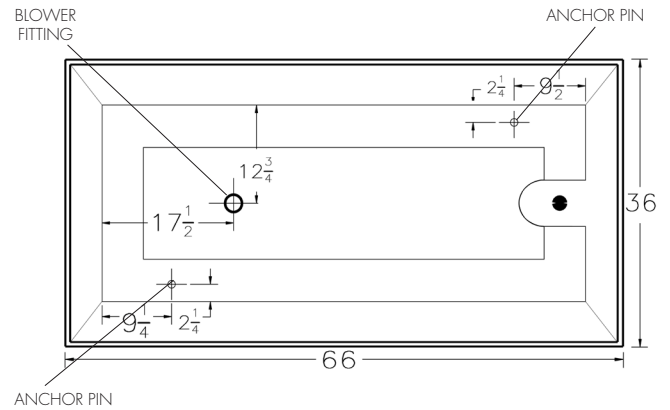

Serenity 24

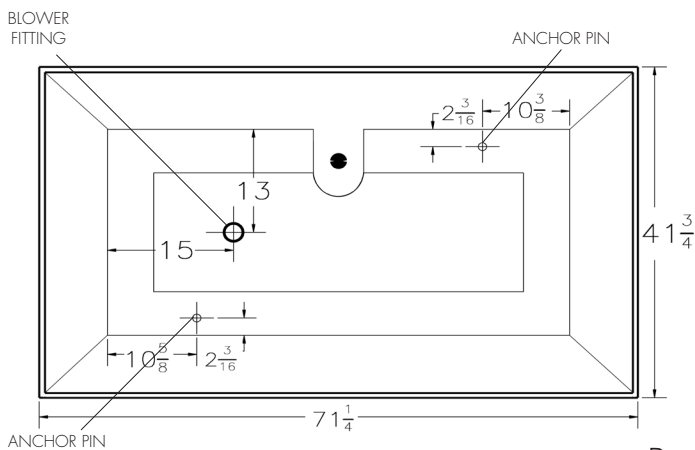

Serenity 25

Bottom View

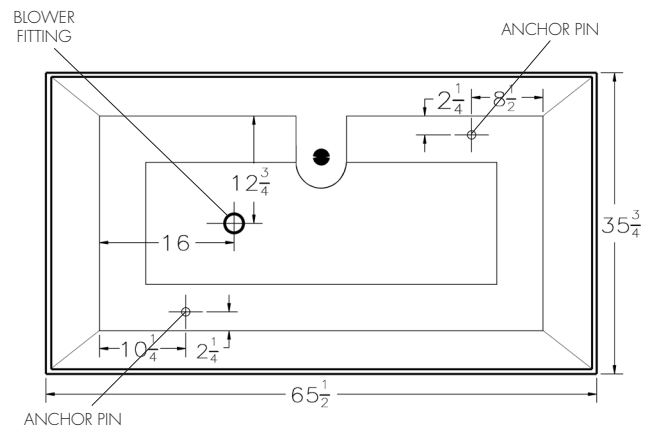

Serenity 26

# INSTALLATION INSTRUCTIONS

## FREESTANDING MODELS

- To prevent the bath from moving sideways, secure the two anchoring pins ( $3/8" \times 3"$  lag bolts, not supplied) to the floor (see Diagram 4A). Leave the lag bolts  $1\ 1/2"$  above floor. Wipe off the marker tracings.
- Install the overflow and drain on the bath. Cut pipes to desired length prior to assembly (see Diagram 4B). Glue the first pipe section (PVC  $1\ 1/2"$ ) of the air passage to go under the floor and make sure pins are lined up with holes in tub. Apply a silicone seal under the rim of the base and lay the bath down putting the pipes through the floor. Immediately remove any excess silicone.

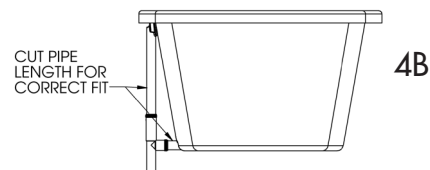
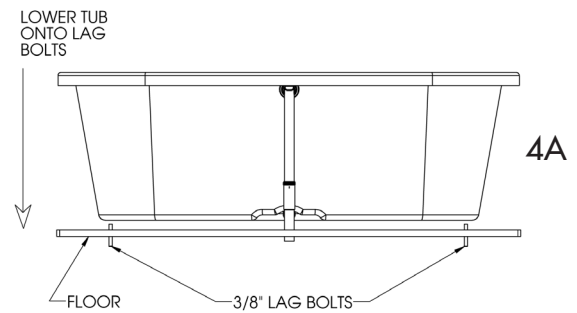

# INSTALLATION INSTRUCTIONS

## FREESTANDING MODELS

### VARIABLE SPEED AIR BLOWER REMOTE MOUNTING for freestanding models

#### Designating a Remote Location

The designated location for the blower must not exceed more than 15 feet of pipe and 6 directional changes. Choose a place as close to the bath as possible to make sure that the system works properly. The chosen place must not be cluttered and/or dusty and must allow for sufficient air circulation. The air around the blower should be approximately 72°F (20°C) for optimal performance. The blower and control box must be accessible at all times.

#### Installing the Blower in a Remote Location

The blower will come attached to the one way check valve, make sure the arrow on the valve is pointing away from the blower.

The blower can be installed horizontally or vertically. The blower intake may be installed up or down. Use PVC 1 1/2" pipe and adapters only. Whenever possible, use two 45° elbows instead of one 90° elbow to change the direction of your pipe. Glue all pipe connections along the extension you have added.

The blower should be 6" off the floor or ceiling and the air intake end of the blower should be at least 4" from any walls or joists. The location of the blower should not be air tight; a gap of 1" is recommended for good air circulation. To reduce heat loss, insulate the pipe.

#### Sample Installations:

Serenity 10 & 37

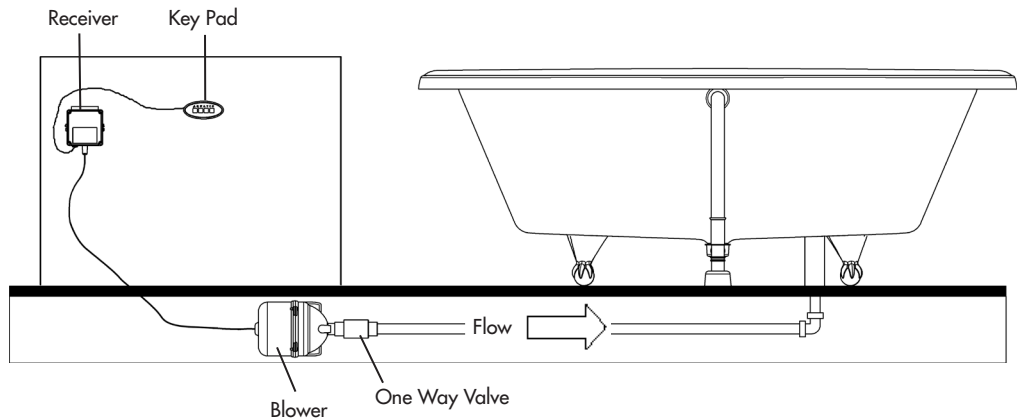

Serenity 10 & 37

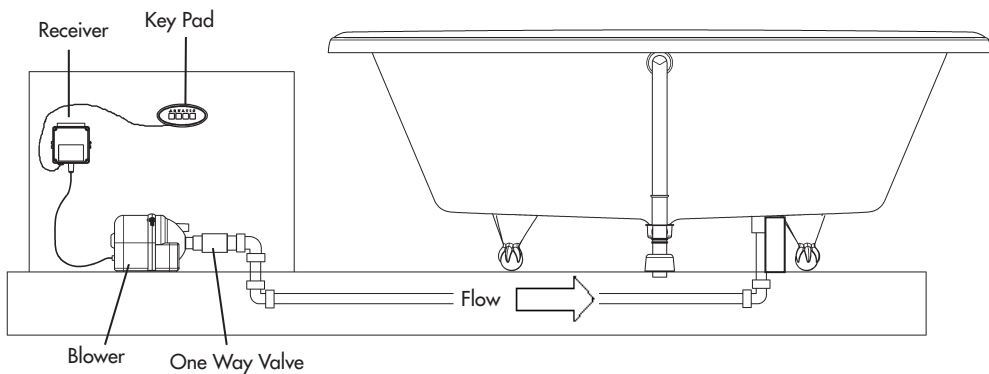

# INSTALLATION INSTRUCTIONS

## FREESTANDING MODELS

### Sample Installations:

Serenity 11, 13, 17,  
23, 24, 25 and 26

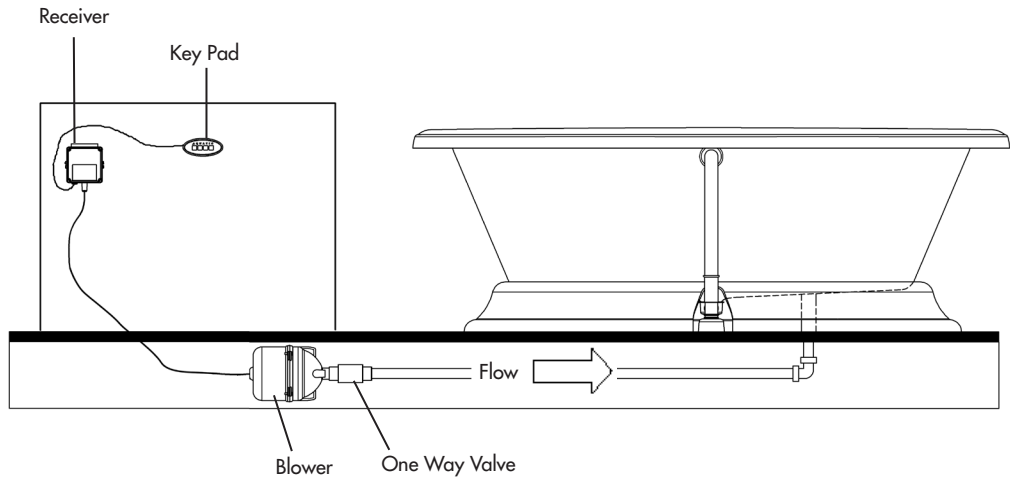

Serenity 11, 13, 17,  
23, 24, 25 and 26

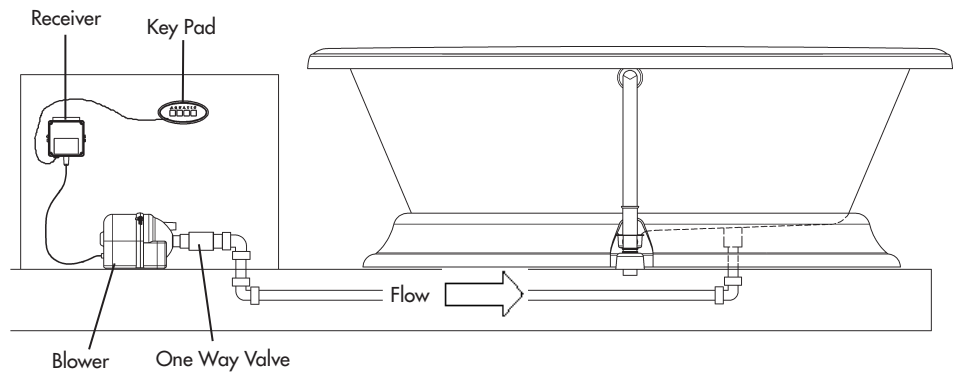



# INSTALLATION INSTRUCTIONS

## FREESTANDING MODELS

### SERENITY 27 INSTALLATION

Before the floor installation is complete, make sure the floor is level. Once the floor installation is complete, determine the exact location of the bath and trace the contour of the bath with an erasable marker pen.

For information on electrical installation, maintenance and care, troubleshooting and warranty, please refer to the Table of Contents.

1. Install the overflow and drain on the bath. Cut pipes to desired length prior to assembly. Glue the first pipe section (PVC 1 1/2") of the air passage to go under the floor. Apply a silicone seal under the rim of the base and lay the bath down putting the pipes through the floor. Immediately remove any excess silicone.
2. Find a location for the Hartford Loop; you can mount the Hartford Loop inside a wall or on a wall in an adjacent room.
3. The top 2 inches of the Hartford Loop must be above the bottom of the over flow hole. (See diagram)
4. Under the tub will be a one way check valve. Attach PVC pipe to this valve and run the pipe under or in the floor to one end of the Hartford Loop.
5. Attach the other end to the one way check valve attached to the blower. Both check valves will have an arrow indicating air flow. Make sure the arrows point towards the tub.
6. If the blower will be installed in an enclosure, you must provide a minimum 4" x 4" opening for ventilation.

**NOTE:** Because the Serenity 27 is a one-of-a-kind bath, dimensions may vary up to several inches. Please take all measurements directly from the bath.

# INSTALLATION INSTRUCTIONS

## FREESTANDING MODELS

The Hartford loop can be installed in or on a wall (see directions) anchored to a 2x4.  
 Install so that two inches of loop is above the bottom of the overflow hole.

### Sample Installations:

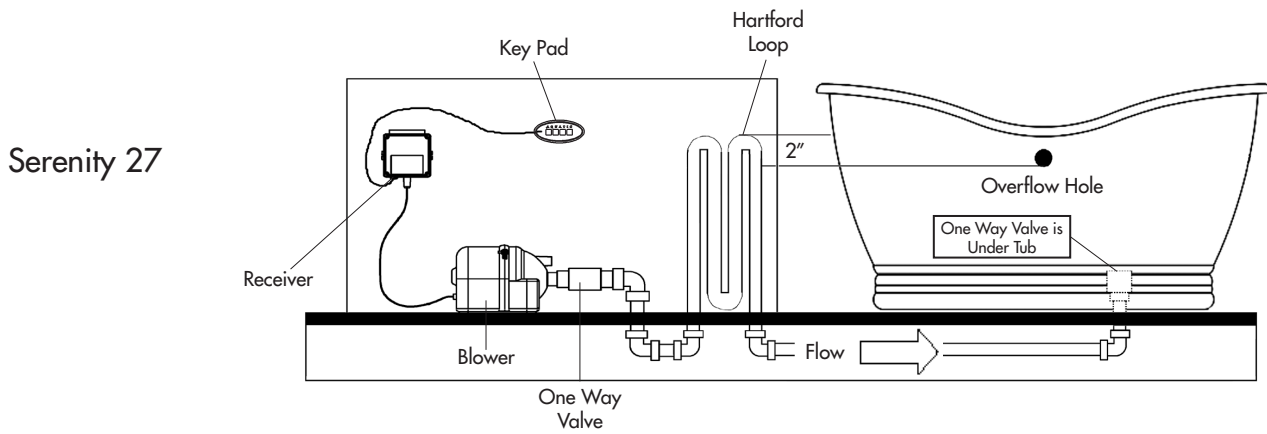
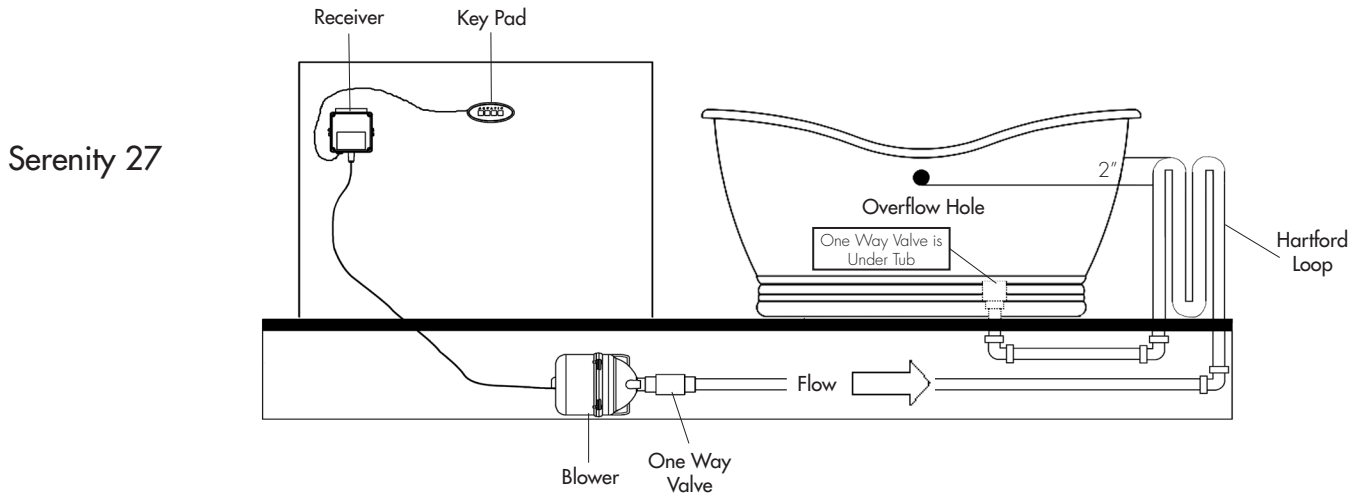

# INSTALLATION INSTRUCTIONS

## NON-FREESTANDING MODELS

### REMOTE CONTROL OPTION (NON-FREESTANDING)

Receiver Module and remote may be used in conjunction with supplied keypad or without.

#### Receiver Module Installation

The receiver module must be installed under the bathtub rim as shown in Figure 7A.

#### **IMPORTANT:**

- In order to obtain the best reception possible, we recommend not to install the receiver module next to the faucets or metal piping.
- Location of the receiver module must be easily accessible from the outside of the bathtub for maintenance.

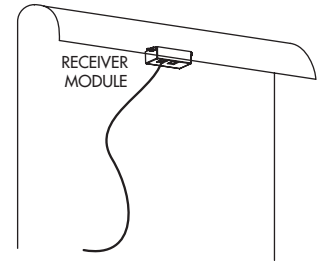

Figure 7A

#### Remote Control and Keypad Used to Activate the System

1. Plug in the cable as shown in Figure 7B.
2. Once everything is connected, the remote control is ready for synchronization.

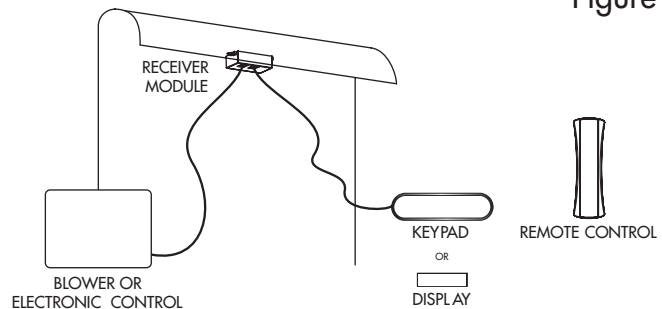
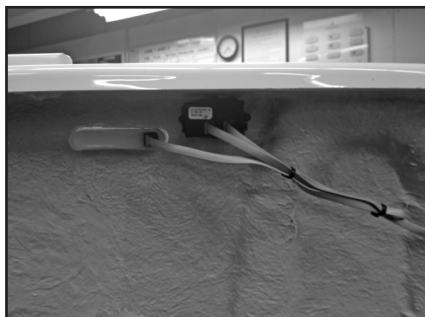

Figure 7B

#### Synchronization

1. Once the system has been connected, the remote control must be synchronized with its receiver module.
2. Switch off the main breaker or unplug the system and switch it on again.
3. From this moment you have 15 seconds to proceed with the synchronization.
4. Press simultaneously on buttons 1 & 2 of the remote for 4 seconds as shown in Figure 8.
5. The remote control is now synchronized and ready for use.
6. If the synchronization is not successful the first time, you should resynchronize, starting from step 2.



Module and keypad are factory installed



Figure 8

# INSTALLATION INSTRUCTIONS

## NON-FREESTANDING MODELS

### REMOTE CONTROL OPTION (NON-FREESTANDING) (CONT.)

#### Remote Control Installation

The following components are necessary

- 1 remote control
- 2 magnets
- 1 receiver module
- 1 cable

1. Determine the appropriate location for the remote control in the bathtub.
2. Determine backside location of magnets
  - A. Hold the remote control in the chosen location.
  - B. From the exterior of the bathtub position the supplied magnets, the attraction force will guide you to the proper area and they will hold in place.
  - C. Mark the position of the magnets with a marker or pencil.

**CAUTION:** Magnets always have a positive and negative side and will only be attracted to one side. Consider this to avoid applying the silicone to the wrong side.

3. Install magnets on back side
  - A. Apply a dab of silicone to the magnets, place and maintain in the premarked position.
  - B. Let dry in this position.

**WARNING:** The magnets are extremely powerful despite their small size. Use caution while installing and handling to avoid injuries caused by a sudden movement of the magnets clinging together and possibly pinching fingers, skin or other. Persons with physical conditions that could be affected by magnetic fields should avoid using it and/or consult with their physician.

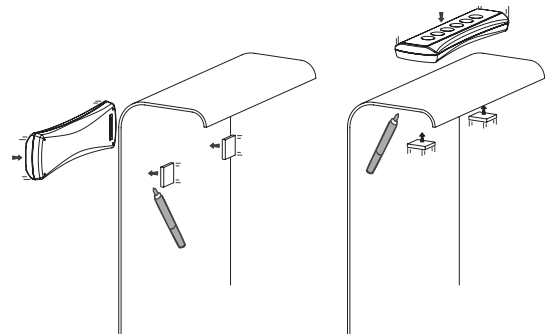
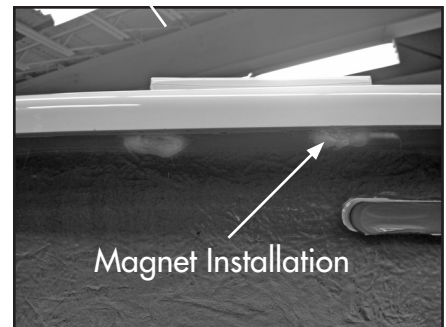

Figure 9A

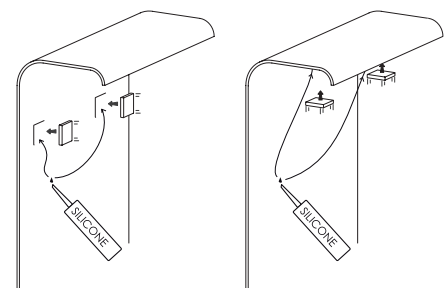

Figure 9B

# INSTALLATION INSTRUCTIONS

## FREESTANDING MODELS

### REMOTE CONTROL (FREESTANDING)

Receiver Module and remote may be used in conjunction with supplied keypad or without.

#### Remote Control and Keypad Used to Activate the System

1. Plug the 25' cable into the blower and the 12" cable into the keypad.
2. The receiver module needs to be mounted within 16" of the keypad.
3. Install the receiver module 6' – 10' from point of use.
4. Once everything is connected, the remote control is ready for synchronization.

#### Remote Control Only to Activate the System

1. Plug the 25' cable into the blower.
2. Install the receiver module 6' – 10' from point of use.
3. Once everything is connected, the remote control is ready for synchronization.

#### Synchronization

1. Once the system has been connected, the remote control must be synchronized with its receiver module.
2. Switch off the main breaker or unplug the system and switch it on again.
3. From this moment you have 15 seconds to proceed with the synchronization.
4. Press simultaneously on buttons 1 & 2 of the remote for 4 seconds as shown in Figure 11.
5. The remote control is now synchronized and ready for use.
6. If the synchronization is not successful the first time, you should resynchronize, starting from step 2.



Figure 10

# INSTALLATION INSTRUCTIONS

## FINAL SYSTEM TEST & CLEAN-UP

### System Test

To test system, follow these steps in order listed:

1. Fill clean tub with water to a minimum of 4" above the air channels.
2. To test the Ground-Fault Circuit-Interrupter (GFCI), push the test button. The GFCI should interrupt power. Push the reset button. Power should be resorted. If the GFCI fails to operate in this manner, there is a ground current flowing, indicating the possibility of an electric shock. Do not use this unit. Disconnect the unit and have the problem corrected by a licensed electrician before using.
3. Push on/off button on the air bath unit.
4. Allow system to run a full 10 minutes.
5. Through access door or removable skirt, check for leaks in air bath plumbing system. Make sure half-union at blower is hand-tight. If leakage is occurring at any other points, notify distributor.
6. If any electrical malfunctions occur, immediately unplug the unit and consult a licensed electrician. Malfunctions of the air bath controls or the circulating system should be reported to the distributor who supplied the tub.

### Clean-up

1. Remove all construction residue and foreign materials. Wipe unit clean with a damp rag, otherwise staining may occur.
2. Plaster may be removed by scraping with the edge of a piece of wood or rigid plastic. DO NOT use metal scraper. For spots left by plaster or grout: rub lightly with a liquid detergent (Spic-N-Span® or similar) on a damp cloth or sponge.
3. **DO NOT** use abrasive cleaners, scouring powders, steel wool, wire brushes or anything else that may harm or dull the surface.
4. Paint, tar or stubborn stains may be removed with paint thinner, turpentine or rubbing alcohol. To avoid discoloration, cleaners containing petroleum distillate must not remain on surfaces. NEVER use lacquer thinner or chlorinated solvents.
5. Dulled areas can be restored to a high gloss with white or cream-colored automotive rubbing compound, followed by application of carnauba wax or white or cream automotive paste wax and buffing.
6. Major gouges require professional repair. Contact Aquatic to arrange factory-authorized repair services.

# OPERATION

## NON-FREESTANDING MODELS

### BATHSIDE CONTROL SYSTEMS (NON-FREESTANDING TUBS)

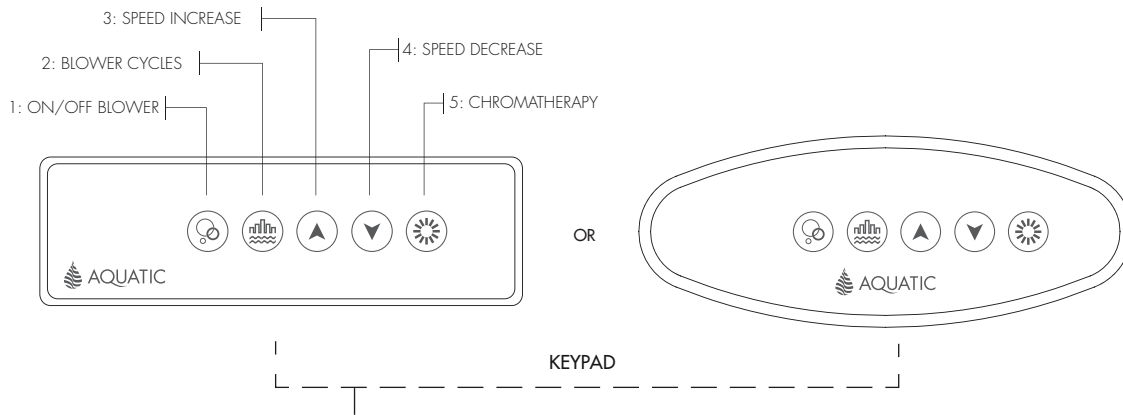

KeyPad Functions	LED
<b>1: ON/OFF BLOWER</b>	
1st Press: The blower starts	ON
2nd Press: The blower stops	OFF
<b>2: BLOWER CYCLES</b>	
1st Press: Wave Cycle - Speed goes gradually from maximum to minimum.	ON
2nd Press: Pulse Cycle - Speed goes from minimum then straight back to maximum.	BLINK
3rd Press: Returns to maximum speed	OFF
<b>3: SPEED INCREASE</b>	
1st Press: Press and hold to increase the blower speed, release pressure at the desired speed. When in cycles mode, increases the speed at which the cycle operates.	ON (WHEN PRESSED)
<b>4: SPEED DECREASE</b>	
1st Press: Press and hold to decrease the blower speed, release pressure at the desired speed. When in cycles mode, decreases the speed at which the cycle operates.	ON (WHEN PRESSED)
<b>5: Chromatherapy</b>	
1st Press: Turn on the light in white	
2nd Press: Rainbow cycle – Low speed	
3rd Press: Rainbow cycle – High speed	
4th Press: Turquoise	
5th Press: Blue	
6th Press: Magenta	
7th Press: Red	
8th Press: Orange	
9th Press: Yellow	
10th Press: Green	
11th Press Turn off the light <i>(Press and hold 2 seconds at any time to turn off the light.)</i>	
<b>Advanced Programming</b>	
<b>DRYING CYCLE WITH WATER DETECTORS</b> The drying cycle will activate 20 minutes after the bathtub is emptied even if the system was not used. The blower touch LED blinks while waiting for the purge cycle.	
<b>INTEGRATED 20 MINUTE AUTOMATIC TIMER</b> Integrated 20 minute automatic timer on the complete system. Count down starts with the last system turned on.	

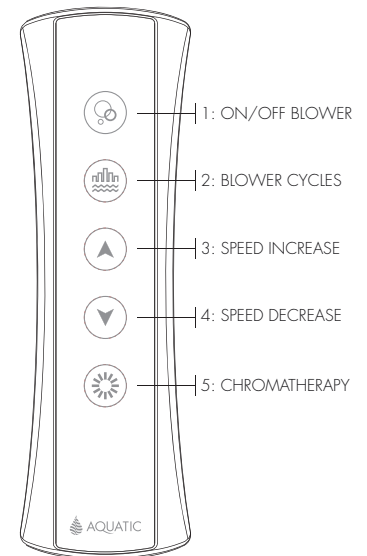

**REMOTE CONTROL**  
(Same Functionality as Keypad)

# OPERATION

## FREESTANDING MODELS

### BATHSIDE CONTROL SYSTEMS (FREESTANDING TUBS)

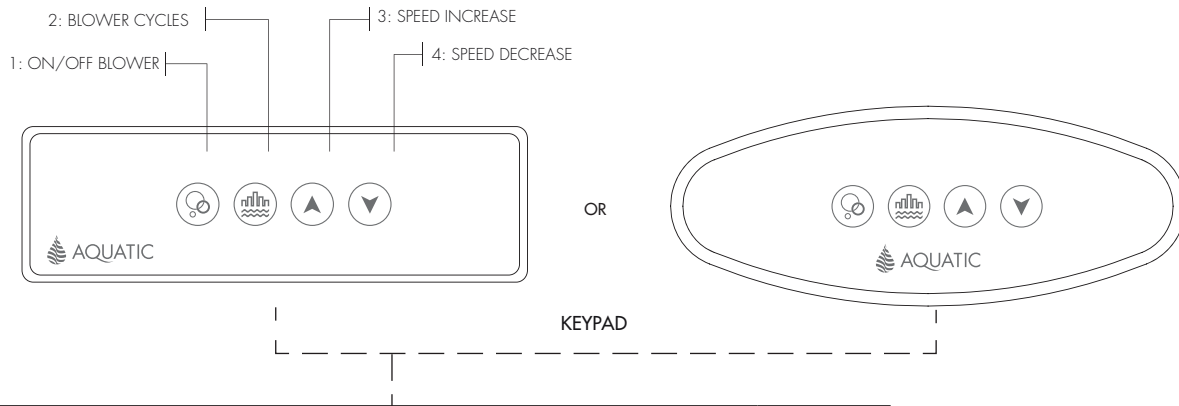

KeyPad Functions	LED
<b>1: ON/OFF BLOWER</b>	
1st Press: The blower starts	ON
2nd Press: The blower stops	OFF
<b>2: BLOWER CYCLES</b>	
1st Press: Wave Cycle - Speed goes gradually from maximum to minimum.	ON
2nd Press: Pulse Cycle - Speed goes from minimum then straight back to maximum.	BLINK
3rd Press: Returns to maximum speed	OFF
<b>3: SPEED INCREASE</b>	
1st Press: Press and hold to increase the blower speed, release pressure at the desired speed. When in cycles mode, increases the speed at which the cycle operates.	ON (WHEN PRESSED)
<b>4: SPEED DECREASE</b>	
1st Press: Press and hold to decrease the blower speed, release pressure at the desired speed. When in cycles mode, decreases the speed at which the cycle operates.	ON (WHEN PRESSED)
<b>Advanced Programming</b>	
<b>INTEGRATED 20 MINUTE AUTOMATIC TIMER</b> Integrated 20 minute automatic timer on the system.	
<b>DRYING CYCLE</b> A 1 minute automatic drying cycle will start 20 minutes after the blower is turned off. The blower LED button blinks while waiting for the purge cycle.	

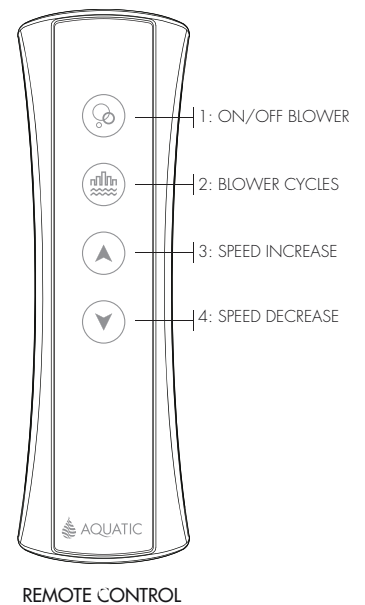



# OPERATION

NON-FREESTANDING MODELS

## TO REPLACE LED LIGHT

1. Disconnect the power to your bathtub.
2. Drain the bathtub.
3. Open the lens of the fixture using **ONLY** the proper tool provided for that purpose. Do not attempt to remove the lens without the provided tool.
4. Replace your LED light (replacement LED lights can be obtained from Aquatic).

**NOTE:** Do not twist LED light into socket. Use gentle pressure and push LED light into place.

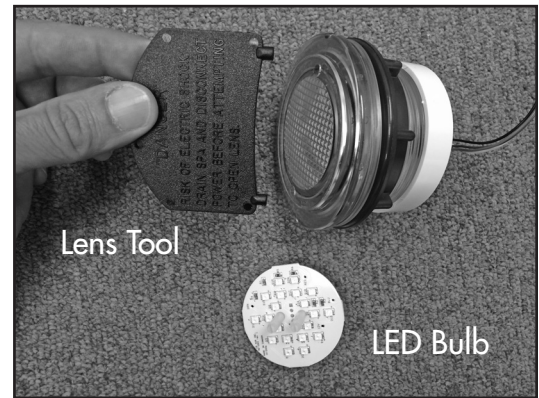

# TUB CARE

## MAINTENANCE

Use common household, non-abrasive cleaners for most cleaning jobs. Clean grease, oil, paint and ink stains with Isopropyl (rubbing) alcohol. Rinse well and dry with a clean cloth or sponge. Do not run the air system with foaming cleaners or soaps. Rinse the bath thoroughly after cleaning. Do not allow your Lucite® acrylic surface to come into contact with products such as acetone (nail polish remover), nail polish, dry cleaning solution, lacquer thinners, gasoline, pine oil or other toxic and oily cleaners.

## FLUSHING / SANITIZING

Before tub is used, your air bath and plumbing system should be flushed. Close the drain. Fill bath with hot water to at least six inches above air injector holes. Add 4 – 6 tablespoons of low sudsing automatic dishwashing detergent and no more than 24-48 ounces of bleach to the water. DO NOT use bleach or other chlorinated cleansers on metal trim surrounding control panel. Turn bath on for approximately two minutes to mix cleaner with water. Shut blower down and allow cleaner to soak in the bath for approximately two hours. Turn on air bath and run for approximately five minutes. Turn air bath unit off and drain tub. Aquatic recommends the above cleaning process on your air bath once a month.

## SURFACE SCRATCH REMOVAL

Minor scratches may be removed by polishing your tub with a non-abrasive car polish, followed by buffing. Deeper scratches can be removed by:

- Sanding with wet 400 grit sandpaper.
- Sanding with wet 600 grit sandpaper.
- Sanding with wet micro-grit sandpaper.
- Buff out using car polish.

## REPAIR

The installation and service of your air bath should be performed only by a qualified service technician. Remember when contacting your distributor always have your serial number, proof of purchase and model number available. This will ensure a quick response on warranty items. See page 3 for serial number location.

**NOTE:** ALL WARRANTY REPAIRS MUST BE AUTHORIZED BY AQUATIC BEFORE WORK IS STARTED. FOR SERVICE, ALWAYS CONTACT YOUR DISTRIBUTOR OR AUTHORIZED SERVICE CENTER.

**CAUTION:** Care should be taken to prevent inappropriate chemicals coming in contact with the Lucite® acrylic surface. Please read and observe all instructions and/or warnings on containers containing substances you contemplate applying to your air bath. Any failure to comply may void your warranty.

## WATER AND AIR TEMPERATURE

Each Serenity model is equipped with a 600 watt air heating system to raise the temperature of the air going into the bath. This air temperature will be less than the bathing temperature of the water, but will help to reduce a rapid decrease in water temperature. In addition, the air coming from the air jets will feel cool against the skin, just as a breeze on a warm day cools your body. This system does not heat the water.

# TUB CARE

## Serenity 27 Copper Air Bath

### CLEANING

- Wash with soap that has low acidic content (anything with acid will act as a polisher), water, and a NON ABRASIVE cloth or sponge.
- NEVER USE anything abrasive, such as Soft Scrub, Clorox or Drano type products.
- DO NOT use a copper polish. You will ruin the tub's finish.
- DO NOT use Flitz Faucet and Fixture Wax. This product will ruin the finish.
- It is highly recommended that you use a car wax to protect the finish on the exterior of the tub.
- Re-wax exterior of tub when needed.
- DO NOT wax the interior of the tub.
- This finish needs to be treated with extra care.

### FLUSHING / SANITIZING

Before tub is used, your air bath and plumbing system should be flushed. Close the drain. Fill bath with hot water to at least six inches above air injector holes. Add two teaspoons of low sudsing automatic dishwashing detergent. DO NOT use bleach or other chlorinated cleansers on metal surfaces. Turn bath on for approximately two minutes to mix cleaner with water. Shut blower down and allow cleaner to soak in the bath for approximately two hours. Turn on air bath and run for approximately five minutes. Turn air bath unit off and drain tub. Aquatic recommends the above cleaning process on your air bath once a month.

The installation and service of your air bath should be performed only by a qualified service technician. Remember when contacting your distributor always have your serial number, proof of purchase and model number available. This will ensure a quick response on warranty items. See page 3 for serial number location.

**NOTE:** ALL WARRANTY REPAIRS MUST BE AUTHORIZED BY AQUATIC BEFORE WORK IS STARTED. FOR SERVICE, ALWAYS CONTACT YOUR DISTRIBUTOR OR AUTHORIZED SERVICE CENTER.

### WATER AND AIR TEMPERATURE

Each Serenity model is equipped with a 600 watt air heating system to raise the temperature of the air going into the bath. This air temperature will be less than the bathing temperature of the water, but will help to reduce a rapid decrease in water temperature. In addition, the air coming from the air jets will feel cool against the skin, just as a breeze on a warm day cools your body. This system does not heat the water.

# WATER QUALITY

## CHEMICAL & WATER QUALITY

Owners of fill and drain air bathtubs need to know basic information concerning water quality, how it affects the performance and enjoyment of the operation of their tubs, and steps that can be taken by the owner to correct related problems. Important issues are the microbiological and chemical quality of the water.

### 1. Microbiological Quality

Microbes are present in water supplied by individual wells or water systems and even in the air around us. These microbes are usually in amounts below what is noticeable. Microbes from the water or air or from a bather's body may settle on wet surfaces such as a bathtub surface or piping system where they can grow in numbers. With regards to air tubs, brown/black fungi/mold or pigmented (colored) bacteria can be noted.

**Fungi/Mold** - Fungi and mold are always present. Usually the levels are such that we don't notice them. When moisture and temperature are sufficient, the organisms will grow to levels that we may smell and/or see. The best examples of such growth is the very common black growth on the bottom of shower curtains. The best solution to keep these surfaces free from the growth is frequent cleaning.

**Pigmented Bacteria** - A pinkish substance may appear on bathroom fixtures that is very persistent, appearing in the shower, sink and along the water line of toilet bowls. The residue is less likely a problem associated with water quality than with naturally occurring airborne bacteria. The bacteria may produce a pinkish film, and sometimes a dark gray film, on surfaces that are regularly moist, including toilet bowls, shower heads, sink drains, and tiles. The problem is more common in humid areas of the country. In any particular case, the determination of the exact species of bacteria causing the problem would require lengthy and costly laboratory testing; however, most experts believe the bacteria responsible is *Serratia marcescens*. These bacteria thrive on moisture, dust and phosphates, and are widely distributed in soil, food and also in animals. The best solution to keep these surfaces free from the bacterial film is continual cleaning. A chlorine containing compound is the best cleaner. Avoid abrasives to limit scratching fixtures, which will make them even more susceptible to bacteria.

### 2. Chemical Quality

The water supplied by individual wells or water systems always contains chemicals, usually in amounts below those which the consumer would notice. Examples of such chemicals, which are of potential concern for the owners of fill and drain air bathtubs, are calcium and magnesium salts, copper, iron, manganese and sulfates. When these chemicals are present in sufficient amounts, they may cause problems in air bathtubs. You should contact your water supply or treatment company and follow their suggestions for treatment.

**Calcium and Magnesium Salts** - Collectively, the various compounds of calcium and/or magnesium are referred to as salts. Calcium and magnesium salts are often found in ground water supplies and cause "hardness" in water. Hard and soft water are relative terms. Hard water retards the cleaning action of soaps and detergents, causing expense in the form of extra work and cleaning agents. When hard water is heated, it will deposit a hard scale. With regard to air bathtubs, high calcium and/or magnesium levels may result in the formation of white stains and scale formation on the inside of the tubs, especially noticeable with colored tubs. If this occurs, you need to contact the water supplier to determine the calcium and/or magnesium content and/or corrosion potential of the water and follow their suggestions for treatment. If you are on an individual well, you need to contact a water treatment company to test your water and suggest solutions if a problem is present.

# WATER QUALITY

**Iron** - Iron is found in many natural waters especially from wells. Iron in water can also result from the corrosion of piping in the water supply system, such as cast iron mains or galvanized steel service lines, or galvanized piping in the home water system. High iron levels may result in the formation of brown stains in the vicinity of the faucet outlets of various fixtures in the home. With air bathtubs, the staining may be particularly pronounced because the aeration action can oxidize iron to a form that settles out on the inside of the tubs, especially noticeable with white tubs. If high iron in the water is present, you can also notice rust colored deposits inside your toilet tank or dishwasher. If this occurs, you need to contact the water supplier to determine the iron content and/or corrosion potential of the water and follow their suggestions for treatment. If you are on an individual well you need to contact the water treatment company to test your water and suggest solutions if a problem is present.

**Manganese** - Manganese is found in many natural waters especially from wells. High manganese levels may result in the formation of small black particles that can stain laundry, especially noticeable with whites such as sheets or towels. With air bathtubs, the formation of small black particles may be particularly pronounced because the aeration action in the tub can oxidize manganese to an insoluble form that is especially noticeable with white tubs. If high manganese in the water is present, you may also notice black stains on white laundry. If this occurs, you need to contact the water supplier to determine the manganese content of the water and follow their suggestions for treatment. If you are on an individual well, you need to contact a water treatment company to test your water and suggest solutions if a problem is present.

### 3. Treatment

If you have contacted your water supplier and followed their instructions and you are still having problems, you need to increase the frequency of applications of low-foaming detergent/bleach starting from monthly purging down to using it every other day as required to eliminate your particular problem. The use of certain bath oils, bubble bath soaps and bath additives may increase the level of accumulations of bath residue in the air system. More frequent cleaning may be necessary if these products are used in the air tub. If excess accumulations persist, you should discontinue the use of these products. If you have followed the monthly purging instructions and still have an excess accumulation of bath residue and desire an alternative cleaning mechanism, we recommend **SUPER SYSTEMS CLEAN PLUS** (Aquatic Part #ST1010) manufactured by Stearns Packaging Corporation to rectify this condition. This may be obtained by contacting Aquatic at (800) 945-2726. It is recommended that you follow the instructions provided by the manufacturer with the product. Repeated use may be necessary. **SUPER SYSTEMS CLEAN PLUS** does not replace the necessity to purge your air system at least once a month with a low foaming detergent and bleach.

# TROUBLESHOOTING GUIDE

**WARNING:** Always turn off power at the main electrical service panel when servicing your air bath.

SYMPTOMS	POSSIBLE PROBLEMS	SUGGESTED SOLUTIONS
Air bath system does not operate:	1) No power to Air Bath unit. 2) Blower Control is not plugged in. 3) Control Panel connector to controller box is disconnected.	1) Reset circuit breakers and GFCI if tripped. Check fuses and replace if bad. 2) Make sure plug is fully inserted into the outlet. 3) Check and reconnect if needed.
Blower turns off by itself or before time elapses:	1) Blower motor overheated and thermal protection device has deactivated motor (possibly low voltage). 2) GFCI tripped.	1) Check that the blower has sufficient ventilation and that the intake to the blower is not blocked. Clear and allow motor to cool down. (check service and wire size.) 2) Refer to installer/dealer/electrician.
Circuit breaker trips repeatedly:	1) Defective breaker. 2) Short circuit between bath and breaker box. 3) Other items are connected to the same circuit.	1) Contact electrician. 2) Contact electrician. 3) Contact electrician.
Blower does not manually shut off:	1) Defective control panel. 2) Defective blower.	1) Refer to installer/dealer. Replace control panel. 2) Refer to installer/dealer. Replace control box.
Air Bath does not function properly while in the pulse or wave modes.	1) Speed of air setting is set too low.	1) Change the air speed setting to a mid-range setting before switching to wave or pulse modes.

## REPLACEMENT PARTS LIST

ILLUSTRATION NO.	PART #	DESCRIPTION
1A.	8162CONTROL	REMOTE CONTROL SERENITY AIR (NON-FREESTANDING)
	8161CONTROL	REMOTE CONTROL SERENITY AIR (FREESTANDING)
1B.	(PACKAGED WITH 1A)	REMOTE RECEIVER MODULE CABLE
1C.		REMOTE RECEIVER MODULE
1D.		REMOTE CONTROL MAGNETS
2A.		8162KEYPAD
2B.	8164KEYPAD	KEYPAD;BDK;SER AIR/LIGHT;OVAL (NON-FREESTANDING)
2C.	8161KEYPAD	KEYPAD;BDL;RECT (FREESTANDING)
2D.	8163KEYPAD	KEYPAD;BDL;OVAL (FREESTANDING)
3A.	8130BOX	CHROMATHERAPY CONTROL BOX (LUXEAIR+SERENITY)
3B.	8020LIGHTS	CHROMATHERAPY;20LEDS BULB;RND CLR
3C.	8LIGHTTOOL	LENS REMOVAL TOOL
3D.	8020LIGHTS	20LEDS CHROMATHERAPY BULB
4A.	8750BLV	BLOWER;750W;VARIABLE;120V;HEATER
4B.	1137	6' KEYPAD CABLE
5A.	8427FTG	1.5" CHECK VALVE
6A.	1138	WATER DETECTOR CABLE 6FT
6B.	8112SENSOR	WATER DETECTOR PROBE
	1136	SENSOR KEYPAD CABLE 25FT
	1135	WATER DETECTOR CABLE 25FT
	1118	25FT CHROMATHERAPY CABLE EXT.

To indicate color, replace XX with "WH" for White, "BI" for Biscuit, "BO" for Bone

# REPLACEMENT PARTS MAP

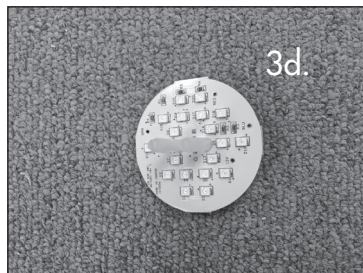
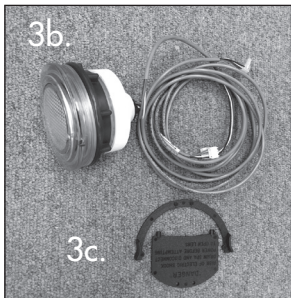
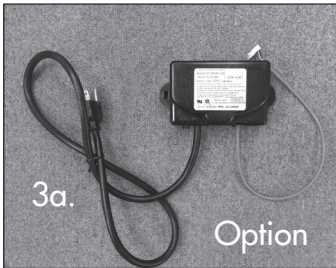
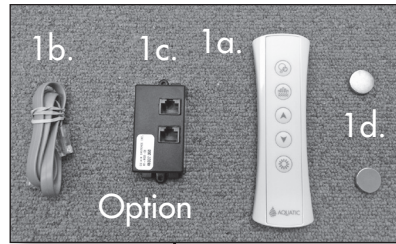



**AQUATIC**

*Where Inspiration Takes Shape*

AQUATIC

Fax-On-Demand System: Toll Free (877) 618-7024

8101 E. Kaiser Blvd., Suite 200 • Anaheim, CA 92808

(800) 945-2726 • Fax (866) 544-5353 • [www.aquaticbath.com](http://www.aquaticbath.com)

8MANSER / F.O.D. 9005 / Rev. 04/14





# SERENITY HOTSOAK™

## OWNER'S MANUAL & INSTALLATION GUIDE

**Installer:** This booklet must be given to the product owner. Please add important information below.

Model # \_\_\_\_\_ Purchase Date \_\_\_\_\_

Serial # \_\_\_\_\_ Distributor \_\_\_\_\_

**Note:** Read all instructions before proceeding with installation.  
All specifications are  $\pm 3/8''$  and are subject to change without notice. Dimensions listed in inches (mm).



## TABLE OF CONTENTS

<b>PRODUCT WARRANTY REGISTRATION INFORMATION</b>	3
<b>IMPORTANT SAFETY INSTRUCTIONS</b>	4 – 5
<b>USER INFORMATION</b>	6
<b>FCC CONSUMER INFORMATION</b>	6
<b>AQUATIC LIMITED WARRANTY</b>	7
<b>INSTALLATION INSTRUCTIONS</b>	
Pre-Installation Procedures	8
Structural Preparation	9 – 10
Plumbing	10
Electrical Connections	11 – 13
Final System Test & Clean-Up	14
<b>OPERATION INSTRUCTIONS</b>	
HotSoak Operations	15
Bath-side On/Off Controls	15
Installation of Electronic On/Off Timer Control	16
Optional Chromatherapy Operation	17
To Replace LED Light	17
<b>TUB CARE</b>	
Maintenance	18
Repair	18
<b>WATER QUALITY</b>	
Chemical & Water Quality	19 – 20
<b>TROUBLESHOOTING GUIDE</b>	21
<b>REPLACEMENT PARTS LIST</b>	22
<b>REPLACEMENT PARTS MAPS</b>	23

## AQUATIC

### Product Warranty Registration Information

Thank you for choosing an Aquatic bath. You have chosen one of the finest bath products in the industry! Aquatic supports your purchase with strong commitments to quality and customer satisfaction.

## IMPORTANT!

To activate Product Warranty please register with Aquatic. Your product warranty must be registered and confirmed with Aquatic through the Serial Number on your unit. To register, please contact Aquatic.

(800) 945-2726 • [www.aquaticbath.com/register](http://www.aquaticbath.com/register)

Please read and follow all of the instructions contained in this Owner's Manual before installing, operating or maintaining your HotSoak. In addition, you should continually refer to these instructions during the life of your HotSoak. Failure to comply with these instructions may invalidate your warranty. If you have any questions concerning installation, operation, maintenance or any other aspect of your Aquatic bath, please contact:

**AQUATIC CUSTOMER SERVICE CENTER: (800) 945-2726**

(The Troubleshooting Guide on page 21 may be helpful in answering some of your questions.)

**NOTE:** The installation and service of your HotSoak should be performed **ONLY** by a qualified electrician and plumber.

## IMPORTANT!

This product **MUST BE WATER-TESTED** and inspected prior to installation or warranty will be voided. [See **TO INSPECT** on page 8.] Neither Aquatic nor the distributor will be responsible for removal or reinstallation costs should replacement of the bath be necessary.

**PLEASE CHECK ENTIRE UNIT FOR ANY DAMAGE.**

If it appears damaged, contact your Aquatic Distributor immediately. Aquatic warranty does not cover damage that occurs in transit.

### SERIAL NUMBER LOCATION

The tub model and serial numbers are located above the pump area on the backside of the bathtub. Your installer should have a service access panel in this location.



**AQUATIC**

*Where Inspiration Takes Shape*

8101 E. Kaiser Blvd., Suite 200 • Anaheim, CA 92808  
(800) 945-2726 • Fax (866) 544-5353  
[www.aquaticbath.com](http://www.aquaticbath.com)

# IMPORTANT SAFETY INSTRUCTIONS

**WARNING:** When using this unit, basic precautions should always be followed, including the following:

## READ AND FOLLOW ALL INSTRUCTIONS:

- **WARNING:** Risk of lethal electric shock. To reduce risk of electric shock, connect only to circuits protected by a Ground-Fault Circuit-Interrupter (GFCI) or Residual Current Device (RCD).
- **DANGER:** To reduce the risk of injury, do not permit children to use this unit unless they are closely supervised at all times.
- Use this unit only for its intended use as described in this manual. Do not use additional attachments and/or equipment not recommended by the manufacturer.
- Never drop or insert any object into any opening.
- Do not operate this unit without the guard over the suction fitting.
- The unit must be connected only to a supply circuit that is protected by a ground-fault circuit-interrupter (GFCI). Such a GFCI should be provided by the installer and should be tested on a routine basis. To test the GFCI, push the test button. The GFCI should interrupt power. Push the reset button. Power should be restored. If the GFCI fails to operate in this manner, there is a ground current flowing, indicating the possibility of an electric shock. Do not use this unit. Disconnect the unit and have the problem corrected by a qualified service representative before using.
- To reduce the risk of injury, enter and exit the bathtub slowly.
- This product is intended for indoor use only. Installing this unit outdoors could cause personal injury and will void your warranty.

SAVE THESE INSTRUCTIONS.

**Your safety and the safety of others are very important.**

We have provided many important safety messages in this manual and on your appliance. Always read and obey all safety messages.



This is the safety alert symbol. This symbol alerts you to potential hazards that can kill or hurt you and others.

All safety messages will follow the safety alert symbol and either the word "DANGER" or "WARNING." These words mean:

**! DANGER**

You can be killed or seriously injured if you don't immediately follow instructions.

**! WARNING**

All safety messages will tell you what the potential hazard is, tell you how to reduce the chance of injury, and tell you what can happen if the instructions are not followed.

# IMPORTANT SAFETY INSTRUCTIONS

**WARNING: WHEN USING THIS UNIT, THESE BASIC PRECAUTIONS SHOULD BE FOLLOWED.**

This manual contains information and instructions for proper operation and maintenance of your HotSoak. Failure to follow these instructions could result in personal injury, electrical shock or fire.

## READ AND FOLLOW ALL INSTRUCTIONS

**DANGER! TO REDUCE THE RISK OF INJURY:**

1. Do not permit children to use this unit unless they are closely supervised by an adult at all times. Supervision is also required when HotSoak is used by an elderly or handicapped individual.
2. Use this unit only for its intended use as described in this manual. Do not use attachments not recommended by the manufacturer.
3. Do not operate this unit without guard over the suction fitting.
4. The water in a bath should never exceed 40°C (104°F). Water temperatures between 38°C (100°F) and 40°C (104°F) are considered safe for a healthy adult. Use time should be limited to approximately 30 minutes, followed by a shower to cool down. Longer exposures may result in hyperthermia. The symptoms of this condition are nausea, dizziness and fainting, which can be fatal. Lower water temperatures are recommended for extended use (exceeding 10-15 minutes) and for young children.
5. Since excessive water temperatures have a high potential for causing fetal damage during the early months of pregnancy, pregnant or possibly pregnant women should limit bath water temperatures to 38°C (100°F).
6. The use of drugs or alcoholic beverages before or during bath use may lead to unconsciousness with the possibility of drowning. Never use the bath while under the influence of alcohol, anticoagulants, stimulants, antihistamines, vasoconstrictors, vasodilators, hypnotics, narcotics or tranquilizers.
7. Persons with a medical history of heart disease, low or high blood pressure, circulatory system problems, or diabetes should consult a physician before using HotSoak.
8. Persons using medication should consult a physician before using HotSoak since medication may induce drowsiness while other medication may affect heart rate, blood pressure and circulation.

**DANGER:** To reduce the risk of injury, enter and exit the bath slowly.

**WARNING:** Never operate electrically connected devices in or near the bath. Never drop or insert any object into any opening within the bath.

This unit must be connected to a supply circuit that is protected by a Ground Fault Circuit Interrupter (GFCI). Such a device should be installed by a licensed electrician and should be tested on a regular basis (at least monthly). To test the GFCI push the TEST button. The GFCI should interrupt the power. Push the RESET button and the power should be restored. If the GFCI fails to operate in this manner there is the possibility of an electric shock, DO NOT USE. Disconnect the unit and have the problem corrected by a qualified service technician. To avoid the possibility of personal injury and discoloration of the acrylic surface, the inlet water temperature should not exceed 60°C (140°F). The bath should be drained after each use. Each bather should start their bath with fresh water.

**CAUTION: DO NOT USE HARSH ABRASIVES OR SOLVENTS FOR CLEANING THIS UNIT.**

**INSTALLER/OWNER BEARS ALL RESPONSIBILITY TO COMPLY WITH ALL STATE AND LOCAL CODES WHEN INSTALLING THIS PRODUCT.**

**SAVE THESE INSTRUCTIONS**

## USER INFORMATION

**Please note:**

No servicing of this product should be done by the user. There are no user serviceable parts. All controls are located in the control recesses on the lip of the tub. These are the only controls that should be used by the consumer. Do not change or alter any of these controls under any circumstances.

Motors are self-lubricating - No lubrication required.

## FCC CONSUMER INFORMATION

Electrical Installation Information Listed on pages 11-13.

This equipment generates and uses radio frequency energy and if not installed and used properly, that is, in strict accordance with the manufacturers instruction, may cause interference to radio and television reception. It has been type tested and found to comply with the limits for a class B computing device in accordance with the specifications in subpart J of part 15 of the FCC rules, which are designed to provide reasonable protection against such interference in a residential installation. However, there is no guarantee that interference will not occur in a particular installation. If this equipment does cause interference, which can be determined by turning the equipment on and off, the user is encouraged to try to correct the interference by one or more of the following measures:

- Reorient the receiving antenna.
- Relocate the receiver with respect to the bath tub.
- Move the receiver away from the bath.
- Plug the receiver into a different outlet so that the receiver and bath are on different branch circuits.
- If necessary, the user should consult the dealer or an experienced radio/television technician for additional suggestions.
- The user may find the following booklet prepared by the FCC helpful: "How To Identify and Resolve Radio-TV Interference Problems." It is available from the U.S. Government Printing Office, Washington, DC 20402, Stock No., 004-000-00345-4.



**Aquatic Limited Warranty**  
**Serenity HotSoak™**  
**Limited Warranty For Original Consumer For Household Usage**

**WHAT PRODUCTS ARE COVERED**

Structures and surface finishes on the HotSoaks and their support systems including equipment, components, attachments and plumbing equipment. Different warranty periods apply to specific components.

**Warranty Periods for Specific Components**

**10 YEAR STRUCTURAL WARRANTY FOR HOTSOAKS SHELL**

Aquatic extends to the original consumer purchaser (the "Purchaser") of the acrylic, fiberglass reinforced shell of HotSoaks a limited warranty that the shell will retain its structural integrity and configuration and be free of water loss due to a defect in the tub shell for a period of 10 years from the date of purchase or 11 years from date of manufacture. This limited structural warranty does not apply to attachments to the acrylic, fiberglass reinforced shell, such as plumbing, fittings and other apparatus; this support equipment pieces is covered below.

**10 YEAR SURFACE WARRANTY FOR FACE OF HOTSOAKS**

The interior surface/face of a HotSoak is warranted against fading, blistering, cracking and delamination due to defects in the surface materials for a period of 10 years from the date of purchase or 11 years from date of manufacture. This surface warranty extends to defects due to surface material mixing or molding. This surface warranty does not apply to fading, cracking, delamination or blistering due to excessive wear, sun fading or scouring due to cleaning.

**2 YEAR EQUIPMENT WARRANTY FOR SUPPORT EQUIPMENT, COMPONENTS, CONTROLS & PLUMBING EQUIPMENT**

All support equipment, components, controls and plumbing equipment on HotSoaks are warranted for 2 years from date of purchase or 3 years from date of manufacture, against defects in workmanship and materials. Fuses and pillows are not included in this limited warranty.

**EXCLUSIVE REMEDY**

Aquatic shall, as its sole obligation, and Purchaser's sole and exclusive remedy for any breach of the limited warranty set forth herein, repair or replace the affected components of any defective HotSoak. If Aquatic determines that repair or replacement of the entire defective HotSoak is not commercially practicable, Aquatic may accept return of the HotSoak and refund the then-current list price of the HotSoak (or, if the HotSoak has been discontinued, of the most nearly comparable current product) to Purchaser for the defect. Any repair, replacement or warranty service by Aquatic hereunder will not extend the applicable warranty periods set forth herein. Unless otherwise agreed upon by Aquatic in writing, Purchaser will bear the costs of access, de-installation, re-installation and transportation of the HotSoak to Aquatic and back to Purchaser.

**WHAT YOU MUST DO**

To obtain warranty service under these warranties:

1. You must be the Purchaser of the HotSoak.
2. You must give prompt written notice to Aquatic at the address detailed below of any defect claim within the warranty period and provide us with any substantiation that we may reasonably request.  
Write to: Aquatic 1521 N. Cooper, Suite 500, Arlington, TX. 76011.
3. HotSoaks must have been installed and maintained in accordance with standard industry practice and with Aquatic's instructions contained in the Owner's Manual and Installation Guide. Please contact Aquatic at the address stated above to obtain a copy of Aquatic's Owner's Manual and Installation Guide.

**EXCLUSIONS**

These limited warranties are null and void if:

1. The HotSoak is subject to damage during shipping by carriers, faulty installation, maintenance, abuse, accident or other damages.
2. The HotSoak is installed outdoors.
3. The HotSoak is not installed in accordance with standard industry practice and Aquatic's instructions contained in the Owner's Manual and Installation Guide.  
Please contact Aquatic at the address stated above to obtain a copy of Aquatic's Owner's Manual and Installation Guide.
4. Unreasonable use of the HotSoak occurs (including any use for non-bathing purposes or failure to provide reasonable and necessary maintenance as specified in Aquatic Owner's Manual and Installation Guide supplied with the HotSoak).
5. The HotSoak is altered, customized, or modified without Aquatic's prior written approval.

**LIMITATIONS**

1. Aquatic HotSoaks sold to Purchasers for industrial, commercial or hotel use are warranted for two years from the original date of purchase or 3 years from date of manufacture, with a limited warranty that the shell will retain its structural integrity and configuration and be free of water loss due to a defect in the HotSoak. The interior surface/face of the HotSoak is warranted against fading, blistering, cracking and delamination due to defects in the surface materials. All support equipment, components, controls and plumbing equipment sold to Purchasers for industrial, commercial or hotel uses on the support equipment, controls, or plumbing is warranted for 1 year from date of purchase or 2 years from date of manufacture. Fuses and pillows are not included in this limited warranty. Aquatic reserves the right to furnish a substitute or replacement HotSoak component in the event the HotSoak component is discontinued or otherwise unavailable.
2. THESE WARRANTIES ARE NON-TRANSFERABLE TO ANY OTHER PURCHASER OR PARTY OTHER THAN THE PURCHASER. NO OTHER AGENT OR PARTY CAN GIVE ANY OTHER WARRANTY OR PROMISE. THIS IS THE SOLE WARRANTY FOR YOUR AQUATIC HOTSOAK.
3. Building Code Compliance is not covered by this limited warranty. Local building codes vary considerably, the Purchaser of the HotSoak is responsible for checking with local building or plumbing contracts to insure local code compliance before installation.
4. Your warranty period starts (begins to run) at the earlier of 1) the beginning of installation of your HotSoak in a home, or 2) the purchase of your HotSoak, and shall never exceed 11 years from the date the HotSoak is manufactured for its shell or finish, or 3 years from the manufacture of plumbing supplies and accessories.

**GENERAL**

EXCEPT FOR THE LIMITED WARRANTIES SET FORTH ABOVE, THE HOTSOAKS ARE PROVIDED "AS IS" WITHOUT ANY REPRESENTATIONS OR WARRANTIES OF ANY KIND. AQUATIC EXPRESSLY DISCLAIMS ALL OTHER WARRANTIES, EXPRESS, IMPLIED, INCLUDING BUT NOT LIMITED TO ANY WARRANTIES OF MERCHANTABILITY, FITNESS FOR A PARTICULAR PURPOSE, TITLE, AND NON-INFRINGEMENT OF THIRD PARTY RIGHTS. AQUATIC DOES NOT WARRANT THAT THE HOTSOAKS FURNISHED HEREUNDER WILL MEET PURCHASER'S REQUIREMENTS OR THAT THE OPERATION OF THE PRODUCT WILL BE UNINTERRUPTED OR DEFECT-FREE OR THAT ALL DEFECTS WILL BE CORRECTED. PURCHASER ACKNOWLEDGES THAT IT HAS RELIED ON NO WARRANTIES OTHER THAN THE EXPRESS WARRANTIES PROVIDED HEREIN.

IN NO EVENT WILL AQUATIC BE LIABLE FOR ANY INDIRECT, SPECIAL, INCIDENTAL, EXEMPLARY OR CONSEQUENTIAL DAMAGES; INCLUDING WITHOUT LIMITATION ANY LOST PROFITS AND COSTS OF PROCUREMENT OF SUBSTITUTE PRODUCT, ARISING OUT OF OR RELATED TO A BREACH OF THIS LIMITED WARRANTY.

Some states do not allow exclusions or limitations on implied warranties. Thus, the above exclusions or limitations may not apply. This warranty gives you specific legal rights. Purchaser may also have other rights which may vary from state to state.

# INSTALLATION INSTRUCTIONS

READ ALL INSTRUCTIONS CAREFULLY BEFORE INSTALLATION

## PRE- INSTALLATION INSTRUCTIONS

**PLEASE NOTE: THE MANUFACTURER ACCEPTS A  $\pm 3/8"$  VARIANCE. THERE ARE VARIATIONS ON EACH TUB AND SPECIFICATIONS ARE SUBJECT TO CHANGE AS WE IMPROVE UPON OUR PRODUCT AS REQUIRED.**

THE DIMENSIONS NEEDED FOR SITE PREPARATION AND STRUCTURE BUILDINGS SHOULD BE MEASURED FROM THE TUB; AQUATIC ASSUMES NO RESPONSIBILITY FOR PREPARATORY WORK.

Note: A good knowledge of construction techniques, plumbing and electrical installation according to codes are required for proper installation. We recommend that a qualified licensed contractor perform the installation of all Aquatic products. Our warranty does not cover improper installation related problems.

1. Immediately upon receiving your Aquatic HotSoak inspect it thoroughly for freight damage. If necessary, contact your dealer/distributor immediately (your dealer/distributor must contact Aquatic within 24 hours of receiving unit to file a claim.) Should inspection indicate any damage, do not install the bath. Damage or defect to the tub surface claimed after the bath is installed is not covered under the warranty.
2. Remove packing material between tub and pump/heater (most models).
3. All baths are filled with water and operated in our manufacturing facility prior to shipment. Inspectors ensure watertight operation, however rough handling may cause leaks which may be detected prior to installation.

### TO INSPECT:

1. Place the tub in an area where it may be drained after testing.
2. Fill the tub to the overflow and allow to stand for a few minutes.
3. Plug in pump cord and run pump for 10 minutes.
4. Inspect the tub completely. Any defect must be reported to Aquatic prior to installation in order to have it covered by warranty. Should inspection indicate any damage or leaks, do not install the bath.

Damage or leaks claimed after the bath is installed are not covered under the warranty.

5. Check to ensure that your installation will conform to all applicable codes and secure necessary permits. All electrical and plumbing connections should be made by qualified electricians and plumbers.

**DAMAGE OR LEAKS CLAIMED AFTER THE BATH IS INSTALLED ARE NOT COVERED UNDER THE WARRANTY.**

**WARNING: FAILURE TO FOLLOW THESE INSTRUCTIONS DURING INSTALLATION WILL RESULT IN TERMINATION OF THE WARRANTY:**

Do not lift the tub by any portion of the plumbing or pump.  
Do not stand in the tub during construction.

**DO NOT MAKE ANY ALTERATIONS, ADDITIONS, OR DELETIONS TO THE WHIRLPOOL SYSTEM, PUMP OR BATH.**

**WARNING:** HotSoak pump and piping are factory assembled. Relocation of pump or other modifications could adversely affect the performance and safe operation of this HotSoak. Aquatic shall not be liable under its warranty or otherwise for personal injury or damage caused by any such unauthorized modification.

**QUIETNESS OF OPERATION:** Aquatic has engineered their baths from base to lip to ensure quality, value, functional design, and maximum bathing comfort. However installation is accountable for as much as 50% of a tub's operating quietness. Please ensure the following:

- The floor structure is adequate to support the installation.
- For quieter operation and heat retention conservation, the walls surrounding the bathtub may be insulated.
- Insulate the tub surround. Do not allow any insulation to come within 3 feet of the pump. The area around the pump must be clean and free of any foreign matter.
- Leave 1/8" to 3/16" gap between tub lip and surround.
- Spread a bed of cement mortar on the floor or subfloor under the tub to reduce vibration and noise.



# INSTALLATION INSTRUCTIONS

## STRUCTURAL PREPARATION

**Note:** The bath should remain in its shipping carton until time of installation.

- Literature dimensions are for reference only. Installation dimensions should be taken directly from the tub. An access panel of 16" x 16" minimum must be provided at the pump end of the tub allowing sufficient clearance to make final connections and for servicing the pump and power panel. Access may be through the wall or platform apron at the end of the unit. In the case of sunken installations, access should be made through the ceiling below.

**IT IS THE INSTALLER'S RESPONSIBILITY TO PROVIDE SUFFICIENT SERVICE ACCESS.  
MAKE ABSOLUTELY CERTAIN THAT ACCESS PANELS AND/OR SERVICE OPENINGS ARE PROPERLY  
PLACED AND THAT ALL POSSIBLE AREAS WHERE SERVICE MAY BE REQUIRED ARE ACCESSIBLE.**

- Install the drain fitting to the bath. **THE DRAIN FITTING WILL PROTRUDE BELOW THE BASE OF THE TUB APPROXIMATELY 1 1/2"**. Clearance must be provided for the drain by cutting away the subfloor (where possible) or by blocking below the tub as may be required. **NOTE:** Watertight installation of the drain and overflow is the installer's responsibility. Drain and/or overflow leakage is not included in the warranty of this product.  
**WARNING:** Factory skirts do not allow for blocking up of the tub base. All blocking must be solid and provide uniform support to the tub base.
- Tub must rest entirely on the base. **DO NOT SUPPORT THE WEIGHT OF THE TUB BY THE RIM.** Where leveling is required, and to reduce vibration noise, prepare a bed of wet mortar in area where tub is to be installed. Carefully level unit, ensuring that uniform support is given to all areas of the base and no portion of the lip is bearing weight.
- Frame out under the tub rim as shown in one of the illustrations below. **NOTE:** Due to the variety of installations possible, framing procedures other than those described may be required. Plumb in selected location using a level. Level front to back and across both sides. A ledge under the rim, or an apron without a ledge, may be constructed as required (see Diagram 1A and 1B). Where installation will be against a wall, stud wall framing should allow for wall sheathing material to run full length to the floor (see Diagram 1C). Install tub firmly against sheathing as dicated, with blocking below rim to prevent deflection or movement of tub. To prevent a rocking movement of tub after installation, it is important to have rim in contact, but not supported by blocking material.
- When placing the tub on a platform or cut out (see Diagrams 1A and 1D), the opening should be 1" smaller than the specified rim dimensions. Extreme care must be taken in this type of installation to ensure the tub will come to rest entirely on the base.

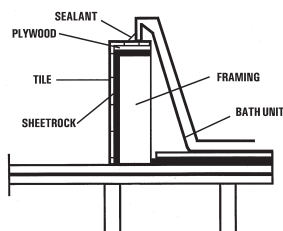

1A Ledge Installation - 1

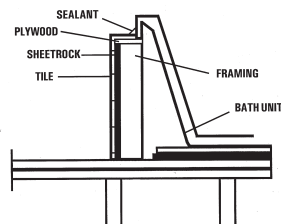

1B Ledge Installation - 2

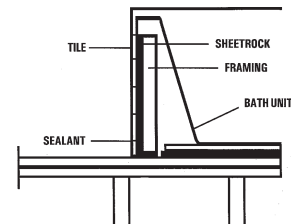

1C Apron Installation

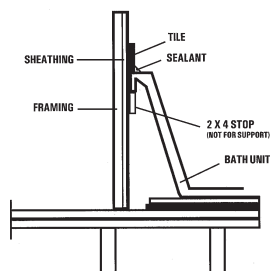

1D Wall Installation

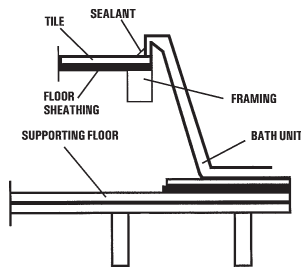

1E Sunken Installation

**WARNING:** ALL ELECTRICAL CONNECTIONS SHOULD BE MADE BY A LOCALLY LICENSED ELECTRICIAN/TECHNICIAN.

# INSTALLATION INSTRUCTIONS

## STRUCTURAL PREPARATION (CONTINUED)

6. Another installation option is that of a tile flange. Aquatic offers a factory installed tile flange for all rectangular and corner-unit tubs.
7. Install the bath unit per the instructions provided in this manual. **CAUTION: THE TILE FLANGE DOES NOT SUPPORT THE TUB!** A ledger board must be provided under the bath rim as indicated in the installation instructions. Take care to ensure tub is not hanging from the ledger boards, as this will void your warranty.

8. Use nails or screws to secure the flange into the studs around the bath.

**NOTE: Before tub is used, the HotSoak system should be cleaned in accordance with the procedures on page 18 of this manual.**

9. Install water resistant drywall against the tile flange and flush to the top of the tub deck. Install the tile or other finishing materials. Apply a second bead of silicone between the first course of tile and the bath deck.

## PLUMBING

1. After securing tub in place, normal waste and overflow, water spout and valves are installed per normal plumbing procedures, in accordance with all state and local standards.
2. Install standard 1-1/2" trap to drain and overflow. Before proceeding make final operational check by filling tub with water to overflow and operate pump for 5 minutes. Check for leaks carefully both while pump is running and has been turned off. Allow water to stand in tub for at least 30 minutes before draining. **AQUATIC WILL NOT BE RESPONSIBLE FOR WATER DAMAGE OF ANY KIND IN CONNECTION WITH ONE OF OUR BATHS.**
3. When selecting fill spout location, check to ensure that spout is long enough to clear the tub rim from its desired location. If installation is to be on the tub deck, check the back side of tub for adequate space for connection to water lines before drilling or cutting tub.
4. A service access panel of a minimum of a 16" square must be provided adjacent to motor/pump/heater assembly.

**NOTE: For Rough-in measurements please refer to unit's technical data sheet.**

# INSTALLATION INSTRUCTIONS

## ELECTRICAL CONNECTIONS

**WARNING:** ALL ELECTRICAL CONNECTIONS SHOULD BE MADE BY A LICENSED, LOCALLY CERTIFIED ELECTRICIAN, IN ACCORDANCE WITH THE REQUIREMENTS OF THE NATIONAL ELECTRICAL CODES AND PROCEDURES.

**WARNING:** WHEN USING ELECTRICAL PRODUCTS, BASIC PRECAUTIONS SHOULD ALWAYS BE FOLLOWED, INCLUDING THE FOLLOWING.

### HOTSOAK

**DANGER: RISK OF ELECTRIC SHOCK!** This unit requires one dedicated 20 AMP, 120V GFCI only (Please see DIAGRAM ON PAGE 12). A GFCI is not supplied, however we do specify its use. All known code authorities require a GFCI.

**BONDING WIRE:** Connect a #8 bare-copper bonding wire from the pump motor/heater to the cold water plumbing or other suitable ground. Grounding is required. **For built-in and custom units, install to permit access for servicing.**

### HOTSOAK with CHROMATHERAPY

HotSoak with chromatherapy requires two dedicated 20 AMP, 120V GFCI only (PLEASE SEE DIAGRAM ON PAGE 13). A GFCI is not supplied, however we do specify its use. All known code authorities require a GFCI.

**BONDING WIRE:** Connect a #8 bare-copper bonding wire from the pump motor/heater to the cold water plumbing or other suitable ground. Grounding is required. **For built-in and custom units, install to permit access for servicing.**

**CAUTION:** Before use of the unit, test the GFCI for proper operation.

# INSTALLATION INSTRUCTIONS

## ELECTRICAL CONNECTIONS

### Serenity HotSoak Component Breakdown

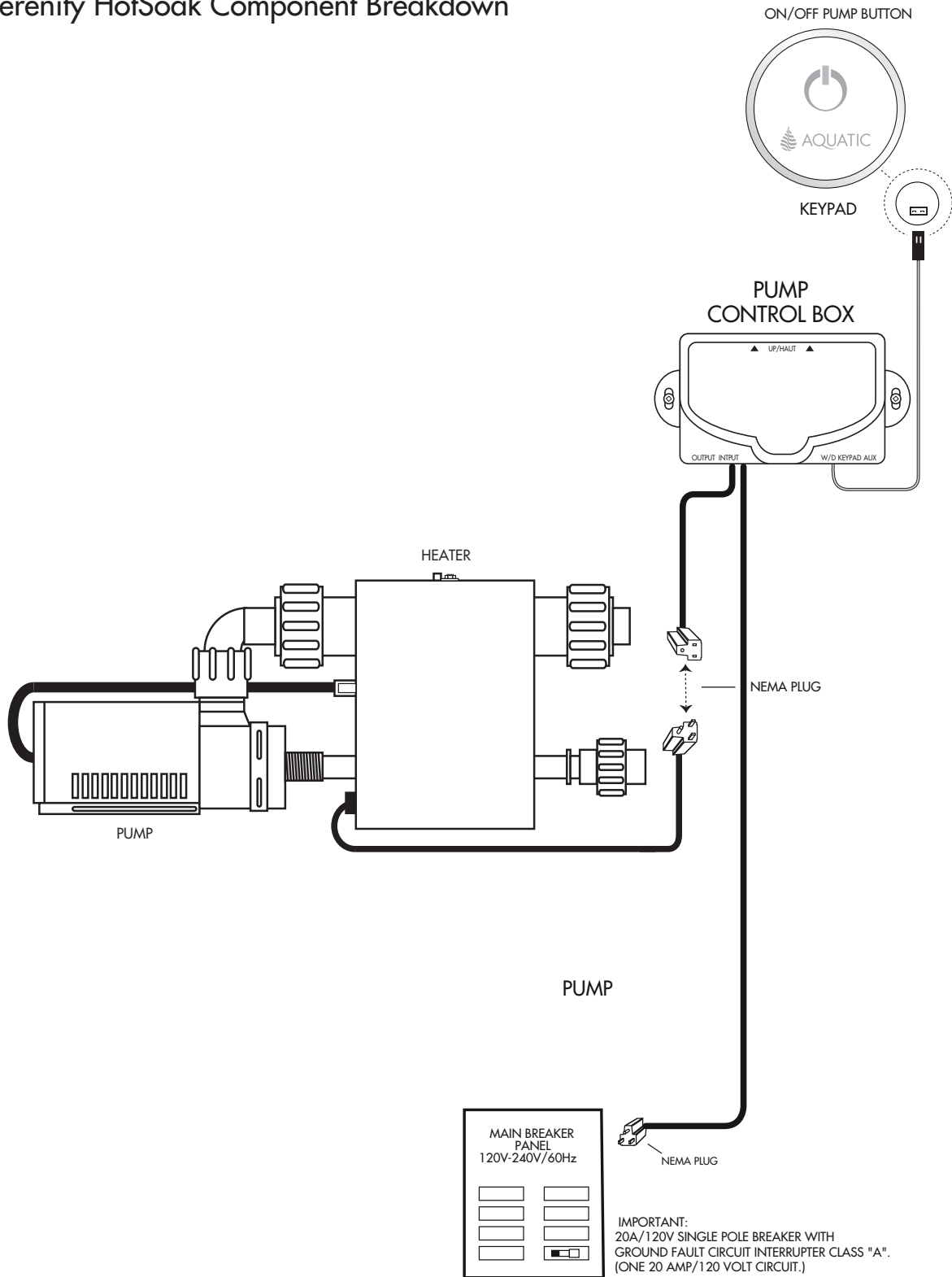

Diagram 2

# INSTALLATION INSTRUCTIONS

## ELECTRICAL CONNECTIONS

### HotSoak with Optional Chromotherapy LED

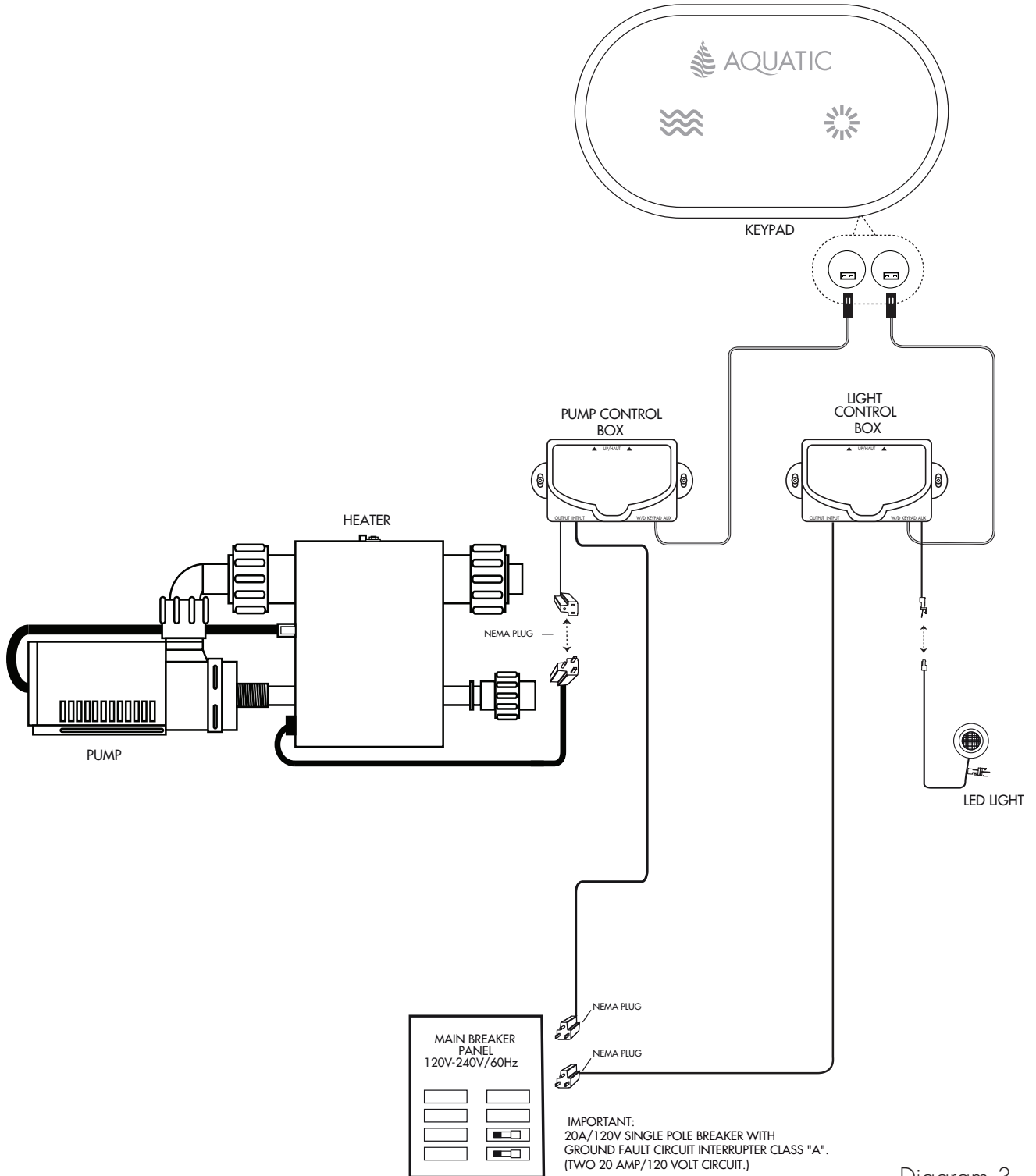

Diagram 3

# INSTALLATION INSTRUCTIONS

## FINAL SYSTEM TEST & CLEAN-UP

### System Test

To test system, follow these steps in order listed:

1. Fill clean tub with water to a point no less than 2" (50) above the highest circulation portal.
2. To test the Ground-Fault Circuit-Interrupter (GFCI), push the test button. The GFCI should interrupt power. Push the reset button. Power should be restored. If the GFCI fails to operate in this manner, there is a ground current flowing, indicating the possibility of an electric shock. Do not use this unit. Disconnect the unit and have the problem corrected by a licensed electrician before using.
3. Push on/off button once to turn HotSoak on.
4. Allow system to run a full 10 minutes.
5. Through access door or removable skirt, check for leaks in HotSoak plumbing system. Make sure half-unions at both ends of pump are hand-tight. If leakage is occurring at any other points, notify distributor.
6. If any electrical malfunctions occur, immediately unplug the unit and consult a licensed electrician. Malfunctions of the pump motor/heater, electronic controls or the circulating system should be reported to the distributor who supplied the bathtub.

### Clean-up

1. Remove all construction residue and foreign materials. Wipe unit clean with a damp rag, otherwise staining may occur.
2. Plaster may be removed by scraping with the edge of a piece of wood or rigid plastic. DO NOT use metal scraper. For spots left by plaster or grout: rub lightly with a liquid detergent (Spic-N-Span® or similar) on a damp cloth or sponge.
3. DO NOT use abrasive cleaners, scouring powders, steel wool, wire brushes or anything else that may harm or dull the surface.
4. Paint, tar or stubborn stains may be removed with paint thinner, turpentine or rubbing alcohol. To avoid discoloration, cleaners containing petroleum distillate must not remain on surfaces. NEVER use lacquer thinner or chlorinated solvents.
5. Dulled areas can be restored to a high gloss with white or cream-colored automotive rubbing compound, followed by application of carnauba wax or white or cream automotive paste wax and buffing.
6. Major gouges require professional repair. Contact Aquatic to arrange factory-authorized repair services.

# OPERATION INSTRUCTIONS

## HOTSOAK OPERATIONS

Operation of the inline maintenance heater is completely automatic. The heater will help maintain the temperature of the water in the tub. The heater includes the following components.

**THERMOSTAT:** The "Smart Thermostat" requires no adjustment and will automatically maintain the water temperature at 100° F - 104° F. Heater comes on at 100° F (low limit). If the bath is too warm, simply adjust by adding cold water.

**HIGH LIMIT:** The heater includes an exclusive "Intelligent High-Limit". This safety circuit will not "false trip" from hot tap water. It will only turn the heater off if the thermostat fails. To reset, simply press the red button. If the high-limit trips frequently, contact Aquatic

**INDICATOR LIGHT:** The light turns on when the heater is operating.

**PRESSURE/VACUUM SWITCH:** The heater is equipped with a preset pressure or vacuum switch. The pump must be running with water flowing to the tub to allow the heater to turn on.

**CAUTION:** Before use of the unit, test the GFCI for proper operation. The pump/heater should turn off when the GFCI "Test" button is pushed.

**WARNING - Prolonged Immersions in Hot Water May Induce Hyperthermia.** Hyperthermia occurs when the internal temperature of the body reaches a level several degrees above the normal body temperature of 98.6° F. The symptoms of hyperthermia include an increase in the internal temperature of the body, dizziness, lethargy, drowsiness, and fainting. The effects of hyperthermia include (1) failure to perceive heat, (2) failure to recognize the need to exit the tub, (3) unawareness of impending hazard, (4) fetal damage in pregnant women, (5) physical inability to exit the tub, (6) unconsciousness resulting in the danger of drowning.

**WARNING -** The use of alcohol, drugs, or medication can greatly increase the risk of fatal hyperthermia.

## BATH-SIDE ON/OFF CONTROLS

The On/Off Electronic Button with Timer is the On/Off Button for the HotSoak pump/heater system.

1. Fill tub with water at least 2 inches higher than the highest circulation portal cover.
2. Push the On/Off Button once to turn HotSoak on. Water will circulate through the circulation portals producing a consistent water temperature. The HotSoak system has a built-in timer and will automatically turn off in approximately 20 minutes.
3. To restart HotSoak after it automatically turns off, simply press the On/Off Button again.
4. When HotSoak is running, press the On/Off Button to turn HotSoak off.

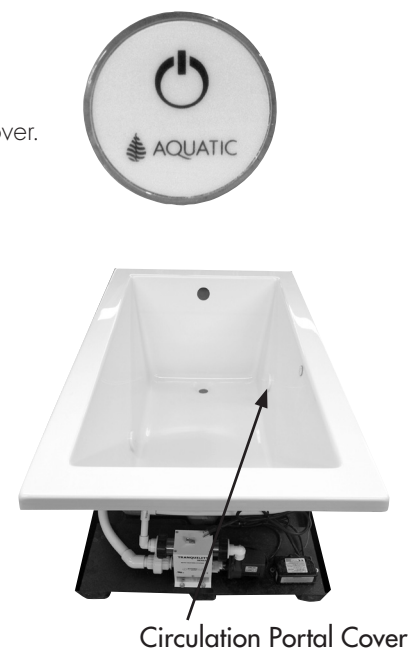

# OPERATION INSTRUCTIONS

## INSTALLATION OF ELECTRONIC ON/OFF TIMER CONTROL

1. Plug the On/Off Timer Control into a dedicated 120-volt, minimum 20-Amp outlet (Speed Timer Box).
2. Wait 10-20 seconds (for self-calibration) before you depress the On/Off Button (Electronic On/Off Button).



1- Speed Timer Box



Electronic On/Off Button



# OPERATION INSTRUCTIONS

## OPTIONAL CHROMATHERAPY OPERATION

KeyPad Functions	
<b>1: On/Off Pump</b>	
1st Press:	The pump starts
2nd Press:	The pump stops
<b>2: Chromatherapy</b>	
1st Press:	Turn on the light in white
2nd Press:	Rainbow cycle – Low speed
3rd Press:	Rainbow cycle – High speed
4th Press:	Turquoise
5th Press:	Blue
6th Press:	Magenta
7th Press:	Red
8th Press:	Orange
9th Press:	Yellow
10th Press:	Green
11th Press:	Turn off the light <i>(Press and hold 2 seconds at any time to turn off the light.)</i>

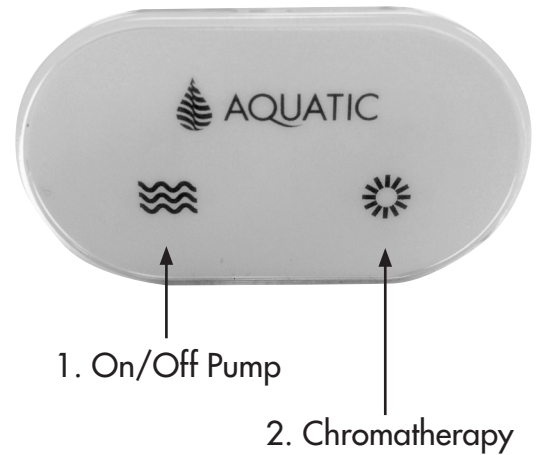

## TO REPLACE LED LIGHT

1. Disconnect the power to your bathtub.
2. Drain the bathtub.
3. Open the lens of the fixture using ONLY the proper tool provided for that purpose. Do not attempt to remove the lens without the provided tool.
4. Replace your LED light (replacement LED lights can be obtained from Aquatic).

**NOTE:** Do not twist LED light into socket. Use gentle pressure and push LED light into place.

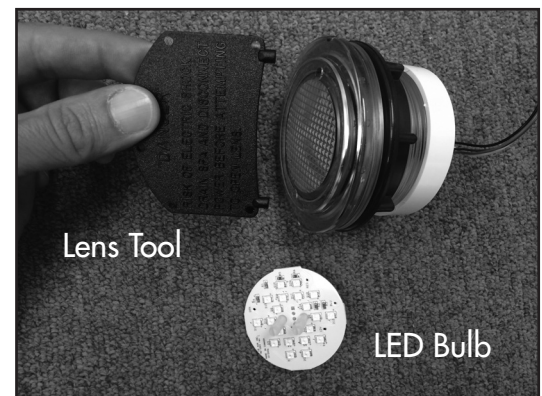

# TUB CARE

## MAINTENANCE

### HotSoak Cleaning

Before tub is used, the HotSoak system should be cleaned and disinfected. Remove all debris and clean tub before putting HotSoak into service. **DO NOT USE ABRASIVE CLEANERS ON THE ACRYLIC FINISH.** Use a non-abrasive detergent and rinse well after cleaning.

- Fill the tub with HOT water to a level 2" above the highest circulation portal cover.
- Add 4 – 6 tablespoons of low-sudsing automatic dishwashing detergent and no more than 24 – 48 ounces of household bleach to the water.
- Operate HotSoak for 10 minutes. Drain.
- Refill with cold water and operate HotSoak for 5 minutes. Drain.

**NOTE:** DO NOT USE OIL OR OIL BASED BATH ADDITIVES. If you want to use any kind of bath additive, use only a small amount of low-foaming powder or crystal substance; the HotSoak action may intensify the foaming properties of soaps. The use of certain bubble baths and bath additives may increase the level of accumulations of bath residue in the HotSoak system. If excess accumulations persist, you should discontinue use of these products.

If you have followed the monthly purging instructions and still have an excess accumulation of bath residue and desire an alternative cleaning mechanism, we recommend SUPER SYSTEMS CLEAN PLUS (Aquatic part #ST1010) manufactured by Stearns Packaging Corporation to rectify this condition. This may be obtained by calling Aquatic, at (800) 945-2726. It is recommended that you follow the instructions provided by the manufacturer with the product. Repeated use may be necessary. SUPER SYSTEMS CLEAN PLUS does not replace the necessity to purge your HotSoak system at least twice a month with a low foaming detergent and bleach.

### Surface Cleaning

Use common household, non-abrasive cleaners for most cleaning jobs. Rinse well and dry with a clean cloth. Never use abrasive cleaners. Do not allow your Lucite® acrylic surface to come into contact with products such as acetone (nail polish remover), nail polish, dry cleaning solution, lacquer thinners, gasoline, pine oil, etc. Remove dust with a soft, dry cloth. Clean grease, oil, paint, and ink stains with isopropyl (rubbing) alcohol.

### Surface Scratch Removal

Minor scratches may be removed by polishing your tub with a non-abrasive car polish, followed by buffing. Deeper scratches can be removed by:

- Sanding with wet 400 grit sandpaper.
- Sanding with wet 600 grit sandpaper.
- Sanding with wet micro-grit sandpaper.
- Buffing out using car polish.

## REPAIR

The installation and service of your bath should be performed only by a qualified service technician. Remember when contacting your dealer always have your serial number, proof of purchase and model number available. This will ensure a quick response on warranty items. The model and serial numbers are located above the pump on the backside of the tub.

**NOTE:** ALL WARRANTY REPAIRS MUST BE AUTHORIZED BY AQUATIC BEFORE WORK IS STARTED. FOR SERVICE, ALWAYS CONTACT YOUR DEALER.

**CAUTION:** Care should be taken to prevent inappropriate chemicals coming in contact with the Lucite® acrylic surface. Please read and observe all instructions and/or warnings on containers containing substances you contemplate applying to your tub. Any failure to comply may void your warranty.

# WATER QUALITY

## CHEMICAL & WATER QUALITY

Owners of fill and drain bathtubs need to know basic information concerning water quality, how it affects the performance and enjoyment of the operation of their tubs, and steps that can be taken by the owner to correct related problems. Important issues are the microbiological and chemical quality of the water.

### 1. Microbiological Quality

Microbes are present in water supplied by individual wells or water systems and even in the air around us. These microbes are usually in amounts below what is noticeable. Microbes from the water or air or from a bather's body may settle on wet surfaces such as a bathtub surface or piping system where they can grow in numbers. With regards to air tubs, brown/black fungi/mold or pigmented (colored) bacteria can be noted.

**Fungi/Mold** - Fungi and mold are always present. Usually the levels are such that we don't notice them. When moisture and temperature are sufficient, the organisms will grow to levels that we may smell and/or see. The best examples of such growth is the very common black growth on the bottom of shower curtains. The best solution to keep these surfaces free from the growth is frequent cleaning.

**Pigmented Bacteria** - A pinkish substance may appear on bathroom fixtures that is very persistent, appearing in the shower, sink and along the water line of toilet bowls. The residue is less likely a problem associated with water quality than with naturally occurring airborne bacteria. The bacteria may produce a pinkish film, and sometimes a dark gray film, on surfaces that are regularly moist, including toilet bowls, shower heads, sink drains, and tiles. The problem is more common in humid areas of the country. In any particular case, the determination of the exact species of bacteria causing the problem would require lengthy and costly laboratory testing; however, most experts believe the bacteria responsible is *Serratia marcescens*. These bacteria thrive on moisture, dust and phosphates, and are widely distributed in soil, food and also in animals. The best solution to keep these surfaces free from the bacterial film is continual cleaning. A chlorine containing compound is the best cleaner. Avoid abrasives to limit scratching fixtures, which will make them even more susceptible to bacteria.

### 2. Chemical Quality

The water supplied by individual wells or water systems always contains chemicals, usually in amounts below those which the consumer would notice. Examples of such chemicals, which are of potential concern for the owners of fill and drain bathtubs, are calcium and magnesium salts, copper, iron, manganese and sulfates. When these chemicals are present in sufficient amounts, they may cause problems in bathtubs. You should contact your water supply or treatment company and follow their suggestions for treatment.

**Calcium and Magnesium Salts** - Collectively, the various compounds of calcium and/or magnesium are referred to as salts. Calcium and magnesium salts are often found in ground water supplies and cause "hardness" in water. Hard and soft water are relative terms. Hard water retards the cleaning action of soaps and detergents, causing expense in the form of extra work and cleaning agents. When hard water is heated, it will deposit a hard scale. With regard to bathtubs, high calcium and/or magnesium levels may result in the formation of white stains and scale formation on the inside of the tubs, especially noticeable with colored tubs. If this occurs, you need to contact the water supplier to determine the calcium and/or magnesium content and/or corrosion potential of the water and follow their suggestions for treatment. If you are on an individual well, you need to contact a water treatment company to test your water and suggest solutions if a problem is present.

**Iron** - Iron is found in many natural waters especially from wells. Iron in water can also result from the corrosion of piping in the water supply system, such as cast iron mains or galvanized steel service lines, or galvanized piping in the home water system. High iron levels may result in the formation of brown stains in the vicinity of the faucet outlets of various fixtures in the home. With bathtubs, the staining may be particularly pronounced because the aeration

## WATER QUALITY

action can oxidize iron to a form that settles out on the inside of the tubs, especially noticeable with white tubs. If high iron in the water is present, you can also notice rust colored deposits inside your toilet tank or dishwasher. If this occurs, you need to contact the water supplier to determine the iron content and/or corrosion potential of the water and follow their suggestions for treatment. If you are on an individual well you need to contact the water treatment company to test your water and suggest solutions if a problem is present.

**Manganese** - Manganese is found in many natural waters especially from wells. High manganese levels may result in the formation of small black particles that can stain laundry, especially noticeable with whites such as sheets or towels. With bathtubs, the formation of small black particles may be particularly pronounced because the aeration action in the tub can oxidize manganese to an insoluble form that is especially noticeable with white tubs. If high manganese in the water is present, you may also notice black stains on white laundry. If this occurs, you need to contact the water supplier to determine the manganese content of the water and follow their suggestions for treatment. If you are on an individual well, you need to contact a water treatment company to test your water and suggest solutions if a problem is present.

### 3. Treatment

If you have contacted your water supplier and followed their instructions and you are still having problems, you need to increase the frequency of applications of low-foaming detergent/bleach starting from monthly purging down to using it every other day as required to eliminate your particular problem. The use of certain bath oils, bubble bath soaps and bath additives may increase the level of accumulations of bath residue in the air system. More frequent cleaning may be necessary if these products are used in the air tub. If excess accumulations persist, you should discontinue the use of these products. If you have followed the monthly purging instructions and still have an excess accumulation of bath residue and desire an alternative cleaning mechanism, we recommend **SUPER SYSTEMS CLEAN PLUS** (Aquatic part #ST1010) manufactured by Stearns Packaging Corporation to rectify this condition. This may be obtained by contacting Aquatic at (800) 945-2726. It is recommended that you follow the instructions provided by the manufacturer with the product. Repeated use may be necessary. **SUPER SYSTEMS CLEAN PLUS** does not replace the necessity to purge your air system at least once a month with a low foaming detergent and bleach.

# TROUBLESHOOTING GUIDE

**WARNING:** Always turn off power at the main electrical service panel when servicing your tub.

SYMPTOMS	POSSIBLE PROBLEMS	SUGGESTED SOLUTIONS
Motor does not start	<ol style="list-style-type: none"> <li>1) GFCI or circuit breaker in OFF position.</li> <li>2) Fuses blown or thermal overload open.</li> <li>3) Locked motor shaft.</li> <li>4) Motor windings burned out.</li> <li>5) Defective starting switch inside single-phase motor.</li> <li>6) Disconnected or defective wiring.</li> <li>7) Low voltage.</li> </ol>	<ol style="list-style-type: none"> <li>1) Reset GFCI (if optional heater is installed, be sure there are two GFCI circuits.)</li> <li>2) Contact your electrician.</li> <li>3) Contact Aquatic.</li> <li>4) Contact Aquatic.</li> <li>5) Contact Aquatic.</li> <li>6) Check and reconnect if needed.</li> <li>7) Contact your electrician.</li> </ol>
Motor does not reach full speed:	<ol style="list-style-type: none"> <li>1) Low voltage.</li> <li>2) Inadequate ventilation.</li> <li>3) Wiring too small.</li> </ol>	<ol style="list-style-type: none"> <li>1) Contact your electrician.</li> <li>2) Refer to installer/dealer.</li> <li>3) Contact your electrician.</li> </ol>
Motor overheats (protector trips):	<ol style="list-style-type: none"> <li>1) Low voltage.</li> <li>2) Inadequate ventilation.</li> <li>3) Wiring too small.</li> </ol>	<ol style="list-style-type: none"> <li>1) Contact your electrician.</li> <li>2) Refer to installer/dealer.</li> <li>3) Contact your electrician.</li> </ol>
Pump delivers no water	<ol style="list-style-type: none"> <li>1) Leakage of air into suction system.</li> <li>2) Impeller clogged.</li> </ol>	<ol style="list-style-type: none"> <li>1) Check suction screen for clogs.</li> <li>2) Clean and unplug.</li> </ol>
Low pump capacity	<ol style="list-style-type: none"> <li>1) Suction or discharge line partly plugged.</li> <li>2) Pump running at reduced speed.</li> <li>3) Impeller clogged.</li> </ol>	<ol style="list-style-type: none"> <li>1) Clean and unplug.</li> <li>2) See "Motor does not reach full speed."</li> <li>3) Clean and unplug.</li> </ol>
Noisy pump and motor	<ol style="list-style-type: none"> <li>1) Worn motor bearings.</li> <li>2) Pumps touching a stationary object.</li> <li>3) Suction line partly plugged.</li> <li>4) Pump not supported properly.</li> <li>5) Low voltage.</li> </ol>	<ol style="list-style-type: none"> <li>1) Contact Aquatic</li> <li>2) Refer to installer/dealer.</li> <li>3) Clean and unplug.</li> <li>4) Contact Aquatic</li> <li>5) Contact electrician.</li> </ol>
Leakage of water at shaft	<ol style="list-style-type: none"> <li>1) Shaft seal requires replacement.</li> </ol>	<ol style="list-style-type: none"> <li>1) Contact Aquatic</li> </ol>
Leaking unions	<ol style="list-style-type: none"> <li>1) O-ring missing or damaged.</li> <li>2) Plumbing in a bind.</li> <li>3) Loose unions.</li> </ol>	<ol style="list-style-type: none"> <li>1) Contact Aquatic</li> <li>2) Contact Aquatic</li> <li>3) Tighten unions.</li> </ol>
Vibration noise	<ol style="list-style-type: none"> <li>1) Tub or tub plumbing is touching tile/wall.</li> <li>2) Pump is touching framing.</li> </ol>	<ol style="list-style-type: none"> <li>1) Refer to installer/dealer.</li> <li>2) Refer to installer/dealer.</li> </ol>

## REPLACEMENT PARTS LIST

ILLUSTRATION NO.	PART #	DESCRIPTION
1A.	1126xx	SUCTION COVER
1B.	–	SUCTION WALL FITTING
1C.	–	SUCTION ELBOW
2A.	8171KEYPAD	KEYPAD;TMS; ESTATE+HOTSOK
3A.	8501CONTROL	CONTROL BOX;TMS;W/P ON/OFF
4A. (OPTION)	8500PAD	KEYPAD KIT;TMS TIMER/LIGHT
5A. (OPTION)	8500CONTROL	CONTROL BOX;CHROMATHERAPY 120V
5B. (OPTION)	8020LIGHTS	CHROMATHERAPY;20LEDS BULB;RND CLR
5C. (OPTION)	8LIGHTTOOL	LENS REMOVAL TOOL
5D. (OPTION)	8020LIGHTS	20LEDS CHROMATHERAPY BULB
6A.	8201PUMP	HEATER/MTR.; 120V, 1500W; W/ PUMP

To indicate color, replace XX with "WH" for White, "BI" for Biscuit , "BO" for Bone

# REPLACEMENT PARTS MAP

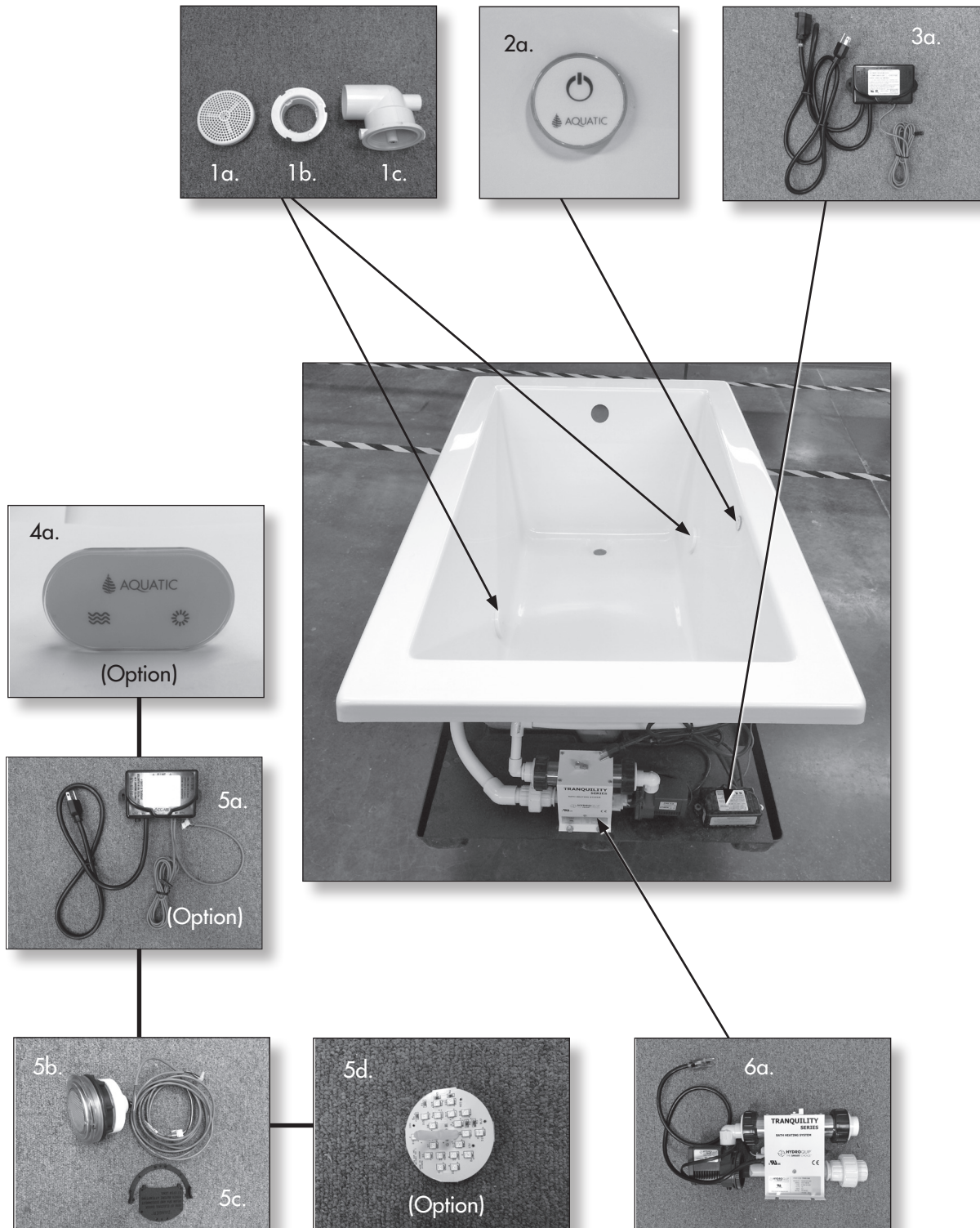



**AQUATIC**

*Where Inspiration Takes Shape*

Fax-On-Demand System: Toll Free (877) 618-7024  
8101 E. Kaiser Blvd., Suite 200 • Anaheim, CA 92808  
(800) 945-2726 • Fax (866) 544-5353 • [www.aquaticbath.com](http://www.aquaticbath.com)

8MANHSK | F.O.D. 9004 | REV. 04.14





# OWNER'S MANUAL & INSTALLATION GUIDE

## Serenity DriftBath™

**INSTALLER: This booklet must be given to the product owner.**

Read all instructions before proceeding. All specifications are  $\pm 3/8''$  and are subject to change without notice. Dimensions listed in inches.

**Model #** \_\_\_\_\_

**Purchase Date** \_\_\_\_\_

**Serial #** \_\_\_\_\_

**Distributor** \_\_\_\_\_



## TABLE OF CONTENTS

<b>PRODUCT WARRANTY REGISTRATION INFORMATION</b>	3
<b>IMPORTANT SAFETY INSTRUCTIONS</b>	4 – 5
<b>DRIFTBATH USER INFORMATION</b>	6
<b>FCC CONSUMER INFORMATION</b>	6
<b>INSTALLATION INSTRUCTIONS</b>	
Pre-Installation Instructions	7 – 8
Structural Preparation	9
Framing Diagrams	10
Deck Cutouts	11
Plumbing	12
Electrical Installation	12
DriftBath with Chromatherapy LED Lights	13
<b>OPERATION INSTRUCTIONS</b>	
Bath-side On/Off Controls	14
<b>TUB CARE</b>	
Maintenance	15
Repair	15
<b>WATER QUALITY</b>	
Chemical & Water Quality	16 – 17
<b>TROUBLESHOOTING GUIDE</b>	18
<b>REPLACEMENT PARTS MAP</b>	19
<b>REPLACEMENT PARTS LIST</b>	20
<b>AQUATIC LIMITED WARRANTY</b>	21

## AQUATIC Product Warranty Registration Information

Thank you for choosing an Aquatic bath. You have chosen one of the finest bath products in the industry. Aquatic supports your purchase with strong commitments to quality and customer satisfaction.

### IMPORTANT!

To activate Product Warranty please register with Aquatic. Your product warranty must be registered and confirmed with Aquatic through the Serial Number on your unit. To register, please contact Aquatic.

800.945.2726 • [www.aquaticbath.com/register](http://www.aquaticbath.com/register)

Please read and follow all of the instructions contained in this Owner's Manual before installing, operating or maintaining your DriftBath. In addition, you should continually refer to these instructions during the life of your tub. Failure to comply with these instructions may invalidate your warranty. If you have any questions concerning installation, operation, maintenance or any other aspect of your tub, please contact **CUSTOMER SERVICE: 800.945.2726** (The Troubleshooting Guide on page 18 may be helpful in answering some of your questions.)

**NOTE:** The installation and service of your Tub should be performed **ONLY** by a licensed electrician and plumber.

### IMPORTANT!

This product **MUST BE WATER-TESTED** and inspected prior to installation or warranty will be voided. [See **TO INSPECT** on page 7.] Neither Aquatic nor the distributor will be responsible for removal or reinstallation costs should replacement of the bath be necessary.

**PLEASE CHECK ENTIRE UNIT FOR ANY DAMAGE.**

If it appears damaged, do not install. Contact your Aquatic Distributor immediately. Aquatic warranty does not cover damage that occurs in transit.

#### Serial Number Location

The tub model and serial number is attached to the shell located above the pump area on the backside of the bathtub. Your installer should have a service access panel in this location.

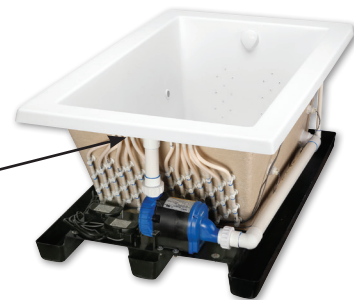

**AQUATIC**

The bath people

Customer Service: 800.945.2726 • [aquaticbath.com](http://aquaticbath.com)



# IMPORTANT SAFETY INSTRUCTIONS

**WARNING:** When using this unit, basic precautions should always be followed. Failure to follow these instructions could result in personal injury, electric shock, or fire.

## READ AND FOLLOW ALL INSTRUCTIONS:

- **WARNING:** Risk of lethal electric shock. To reduce risk of electric shock, connect only to circuits protected by a Ground-Fault Circuit-Interrupter (GFCI) or Residual Current Device (RCD).
- **DANGER:** To reduce the risk of injury, do not permit children to use this unit unless they are closely supervised at all times.
- Use this unit only for its intended use as described in this manual. Do not use attachments not recommended by the manufacturer.
- Never drop or insert any object into any opening.
- Do not operate this unit without the guard over the suction fitting.
- The unit must be connected only to a supply circuit that is protected by a ground-fault circuit-interrupter (GFCI). Such a GFCI should be provided by the installer and should be tested on a routine basis. To test the GFCI, push the test button. The GFCI should interrupt power. Push the reset button. Power should be restored. If the GFCI fails to operate in this manner, there is a ground current flowing, indicating the possibility of an electric shock. Do not use this unit. Disconnect the unit and have the problem corrected by a qualified service representative before using.
- This product is intended for indoor use only. Installing this unit outdoors could cause personal injury and will void your warranty.

SAVE THESE INSTRUCTIONS.

 <b>WARNING</b>

Electrical Shock Hazard
Plug into a grounded 3-prong outlet.
Do not remove ground prong.
Do not use an adapter.
Do not use an extension cord.
Failure to follow these instructions can result in death, fire, or electrical shock.

**Your safety and the safety of others are very important.**

We have provided many important safety messages in this manual and on your appliance. Always read and obey all safety messages.



This is the safety alert symbol. This symbol alerts you to potential hazards that can kill or hurt you and others.

All safety messages will follow the safety alert symbol and either the word "DANGER" or "WARNING." These words mean:

 **DANGER**

You can be killed or seriously injured if you don't immediately follow instructions.

 **WARNING**

All safety messages will tell you what the potential hazard is, tell you how to reduce the chance of injury, and tell you what can happen if the instructions are not followed.

# IMPORTANT SAFETY INSTRUCTIONS

## DANGER! TO REDUCE THE RISK OF INJURY:

1. Do not permit children to use this unit unless they are closely supervised by an adult at all times. Supervision is also required when whirlpool bath is used by an elderly or handicapped individual.
2. The water in a whirlpool should never exceed 40°C (104°F). Water temperatures between 38°C (100°F) and 40°C (104°F) are considered safe for a healthy adult. Use time should be limited to approximately 30 minutes, followed by a shower to cool down. Longer exposures may result in hyperthermia. The symptoms of this condition are nausea, dizziness and fainting, which can be fatal. Lower water temperatures are recommended for extended use (exceeding 10-15 minutes) and for young children.
3. Since excessive water temperatures have a high potential for causing fetal damage during the early months of pregnancy, pregnant or possibly pregnant women should limit whirlpool water temperatures to 38°C (100°F).
4. The use of drugs or alcoholic beverages before or during whirlpool use may lead to unconsciousness with the possibility of drowning. Never use the whirlpool while under the influence of alcohol, anticoagulants, stimulants, antihistamines, vasoconstrictors, vasodilators, hypnotics, narcotics or tranquilizers.
5. Persons with a medical history of heart disease, low or high blood pressure, circulatory system problems, or diabetes should consult a physician before using a whirlpool.
6. Persons using medication should consult a physician before using a whirlpool since medication may induce drowsiness while other medication may affect heart rate, blood pressure and circulation.

**DANGER:** To reduce the risk of injury, enter and exit the bath slowly.

**WARNING:** Never operate electrically connected devices in or near the bath. Never drop or insert any object into any opening within the whirlpool.

To avoid the possibility of personal injury and discoloration of the acrylic surface, the inlet water temperature should not exceed 60°C (140°F). The bath should be drained after each use. Each bather should start their bath with fresh water.

**CAUTION:** DO NOT USE HARSH ABRASIVES OR SOLVENTS FOR CLEANING THIS UNIT. SEE PAGE 15, TUB CARE.

**INSTALLER/OWNER BEARS ALL RESPONSIBILITY TO COMPLY WITH ALL NATIONAL, STATE AND LOCAL CODES WHEN INSTALLING THIS PRODUCT.**

## SAVE THESE INSTRUCTIONS

## DRIFTBATH USER INFORMATION

### PLEASE NOTE:

No servicing of this product should be done by the user. There are no user serviceable parts. All controls are located in the control recesses on the lip of the tub. These are the only controls that should be used by the consumer. Do not change or alter any of these controls under any circumstances.

Motors are self-lubricating – No lubrication required.

## FCC CONSUMER INFORMATION

This equipment generates and uses radio frequency energy and if not installed and used properly, that is, in strict accordance with the manufacturers instruction, may cause interference to radio and television reception. It has been type tested and found to comply with the limits for a class B computing device in accordance with the specifications in subpart J of part 15 of the FCC rules, which are designed to provide reasonable protection against such interference in a residential installation. However, there is no guarantee that interference will not occur in a particular installation. If this equipment does cause interference, which can be determined by turning the equipment on and off, the user is encouraged to try to correct the interference by one or more of the following measures:

- Reorient the receiving antenna.
- Relocate the receiver with respect to the bath tub.
- Move the receiver away from the bath.
- Plug the receiver into a different outlet so that the receiver and bath are on different branch circuits.
- If necessary, the user should consult the dealer or an experienced radio/television technician for additional suggestions.
- The user may find the following booklet prepared by the FCC helpful: "How To Identify and Resolve Radio-TV Interference Problems." It is available from the U.S. Government Printing Office, Washington, DC 20402, Stock No., 004-000-00345-4.

# INSTALLATION INSTRUCTIONS

READ ALL INSTRUCTIONS CAREFULLY BEFORE INSTALLATION

## PRE-INSTALLATION PROCEDURES

PLEASE NOTE: THE MANUFACTURER ACCEPTS A  $\pm\frac{3}{8}$ " VARIANCE. THERE ARE VARIATIONS ON EACH TUB AND SPECIFICATIONS ARE SUBJECT TO CHANGE AS WE IMPROVE UPON OUR PRODUCT AS REQUIRED.

THE DIMENSIONS NEEDED FOR SITE PREPARATION AND STRUCTURE BUILDINGS SHOULD BE MEASURED FROM THE TUB; AQUATIC ASSUMES NO RESPONSIBILITY FOR PREPARATORY WORK.

**Note:** A good knowledge of construction techniques, plumbing and electrical installation according to codes are required for proper installation. We recommend that a qualified licensed contractor perform the installation of all Aquatic products. Our warranty does not cover improper installation related problems.

1. Immediately upon receiving your Aquatic bath inspect it thoroughly for freight damage. If necessary, contact your dealer/distributor immediately (your dealer/distributor must contact Aquatic, Inc. within 24 hours of receiving unit to file a claim.) Should inspection indicate any damage, do not install the bath.
2. All baths are filled with water and operated in our manufacturing facility prior to shipment. Inspectors ensure watertight operation, however, rough handling may cause leaks which may be detected prior to installation.

**Damage or defect to the finish claimed after the bath is installed is not covered under the warranty.**

### To Inspect:

1. Place the tub in an area where it may be drained after testing.
2. Fill the tub with clean water to the overflow and allow to stand for a few minutes. Carefully inspect all fittings and connections for leaks.
3. Plug in pump control box cord and run pump for 10 minutes.
4. Inspect the tub completely. Any defect must be reported to Aquatic prior to installation in order to have it covered by warranty. **Should inspection indicate any damage, do not install the bath.**
5. Check to ensure that your installation will conform to all applicable codes and secure necessary permits. All electrical and plumbing connections should be made by qualified electricians and plumbers.

**Damage or leaks claimed after the bath is installed are not covered under the warranty.**

**WARNING: FAILURE TO FOLLOW THESE INSTRUCTIONS DURING INSTALLATION WILL RESULT IN TERMINATION OF THE WARRANTY: DO NOT LIFT THE TUB BY ANY PORTION OF THE PLUMBING OR PUMP. DO NOT STAND IN THE TUB DURING INSTALLATION/CONSTRUCTION.**

DO NOT MAKE ANY ALTERATIONS, ADDITIONS, OR DELETIONS TO THE SYSTEM PUMP OR BATH.

**WARNING:** Pump and piping are factory assembled. Relocation of pump or other modifications could adversely affect the performance and safe operation of this tub. Aquatic shall not be liable under its warranty or otherwise for personal injury or damage caused by any such unauthorized modification.

# INSTALLATION INSTRUCTIONS

**QUIETNESS OF OPERATION:** Aquatic has engineered their baths from base to lip to ensure quality, value, functional design, and maximum bathing comfort. However, installation is accountable for as much as 50% of a tub's operating quietness. Please ensure the following:

- The floor structure is adequate to support the installation.
- For quieter operation and heat retention conservation, the walls surrounding the tub may be insulated.
- Insulate the tub surround. Do not allow any insulation to come within 3 feet of the pump. The area around the pump must be clean and free of any foreign matter.
- Leave  $\frac{1}{8}$ " to  $\frac{3}{16}$ " gap between tub lip and surround.
- Spread a bed of cement mortar on the floor or subfloor under the tub to reduce vibration and noise.



# INSTALLATION INSTRUCTIONS

## STRUCTURAL PREPARATION

**Note:** The bath should remain in its shipping carton until time of installation.

1. Literature dimensions are for reference only. Installation dimensions should be taken directly from the tub. An unobstructed access panel of 16" x 16" minimum must be provided at the pump end of the tub allowing sufficient clearance to make final connections and for servicing the pump and power panel. Access may be through the wall or platform apron at the end of the unit. In the case of sunken installations, access should be made through the ceiling below.

**IMPORTANT: IT IS THE INSTALLER'S RESPONSIBILITY TO PROVIDE SUFFICIENT SERVICE ACCESS. MAKE ABSOLUTELY CERTAIN THAT ACCESS PANELS AND/OR SERVICE OPENINGS ARE PROPERLY PLACED AND THAT ALL POSSIBLE AREAS WHERE SERVICE MAY BE REQUIRED ARE ACCESSIBLE.**

2. Install the drain fitting to the bath. **THE DRAIN FITTING WILL PROTRUDE BELOW THE BASE OF THE TUB APPROXIMATELY 1 1/2".** Clearance must be provided for the drain by cutting away the subfloor (where possible) or by blocking below the tub as may be required. **NOTE:** Watertight installation of the drain and overflow is the installer's responsibility. Drain and/or overflow leakage is not included in the warranty of this product. **WARNING:** Factory skirts do not allow for blocking up of the tub base. All blocking must be solid and provide uniform support to the tub base.
3. Tub must rest entirely on the base. **DO NOT SUPPORT THE WEIGHT OF THE TUB BY THE RIM.** Where leveling is required, and to reduce vibration noise, prepare a bed of wet mortar in area where tub is to be installed. Carefully level unit, ensuring that uniform support is given to all areas of the base and no portion of the lip is bearing weight.
4. Frame out under the tub rim as shown in the framing diagrams on page 10. **NOTE:** Due to the variety of installations possible, framing procedures other than those described may be required. Plumb in selected location using a level. Level front to back and across both sides. A ledge under the rim, or an apron without a ledge, may be constructed as required, with blocking below rim to prevent deflection or movement of tub. To prevent a rocking movement of tub after installation, it is important to have rim in contact, but not supported by blocking material.
5. When placing the tub on a platform or cut out extreme care must be taken in this type of installation to ensure the tub will come to rest entirely on the base.
6. Another installation option is that of a tile flange. Aquatic offers a factory installed tile flange for all rectangular and corner-unit tubs.
7. Install the bath unit per the instructions provided in this manual. **CAUTION: THE TILE FLANGE DOES NOT SUPPORT THE TUB!** A ledger board must be provided under the bath rim as indicated in the installation instructions. Take care to ensure tub is not hanging from the ledger boards, as this will void your warranty.
8. Pre-drill pilot holes. Use nails or screws to secure the flange into the studs around the bath.

**NOTE: Before tub is used, the DriftBath system should be cleaned in accordance with the procedures on page 15 of this manual.**

9. Install water resistant drywall against the tile flange and flush to the top of the tub deck. Install the tile or other finishing materials. Apply a second bead of silicone between the first course of tile and the bath deck.

# INSTALLATION INSTRUCTIONS

## FRAMING DIAGRAMS

1. Protect interior of tub throughout installation process.
2. Framing and supports will vary according to the model and type of installation selected.
3. Please refer back to the unit's Technical Data sheet for specific dimensions located at [www.aquaticbath.com](http://www.aquaticbath.com).

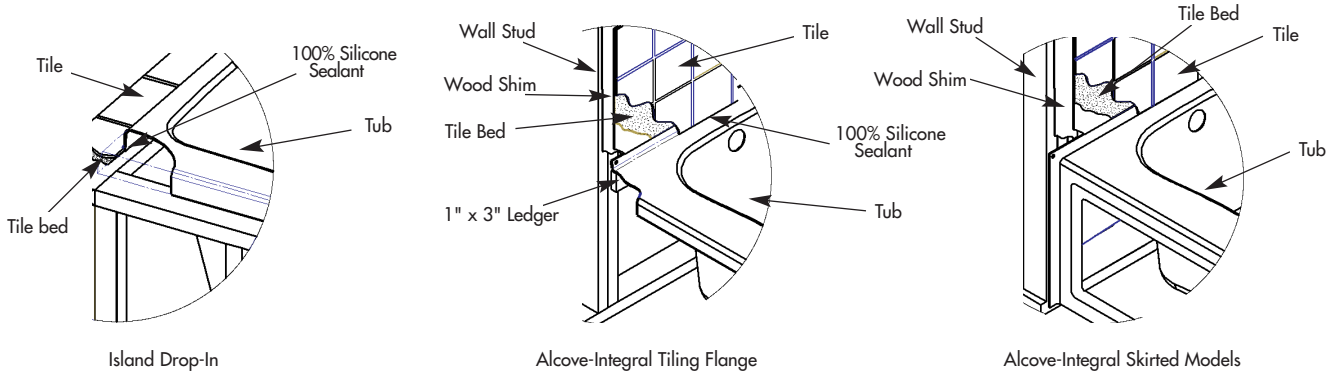

	RECTANGULAR MODELS	CORNER MODELS	OVAL MODELS
ALCOVES			
ISLANDS			
INTEGRALLY SKIRTED MODELS			

*Note: For Skirt Installation disregard front framing*

**LEGEND**

- AW Overall Width
- DH Deck Height
- ID Inner Depth
- IW Inner Width
- LH Ledger Height
- ID Ledger Depth

- A - 6" x 12" Box-outs
- B - Levelled Supports
- 1" x 3" Ledgers
- C - 16" x 16" minimum access on pump end

# INSTALLATION INSTRUCTIONS

## DECK CUTOUTS

A paper template will be enclosed with all rounded-edged models. Use the directions on the paper template for cutout dimensions. **If the paper template has been lost or needs replacement, please contact Customer Service at: 800.945.2726.**

### USING THE CUTOUT TEMPLATE

Draw a center line horizontally and vertically on a 1" thick plywood deck. Place the template in the upper left hand quadrant, noted as Quadrant 1 on the diagram below. Trace template to outline Quadrant 1. Flip the paper cutout horizontally, making sure to match the dotted center line on the template with the center line on the plywood. Trace again to outline Quadrant 2. Repeat until the remaining quadrants of the cutout have been traced.

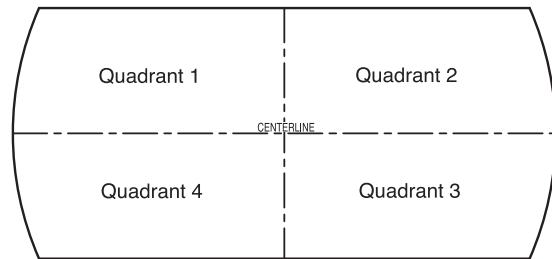
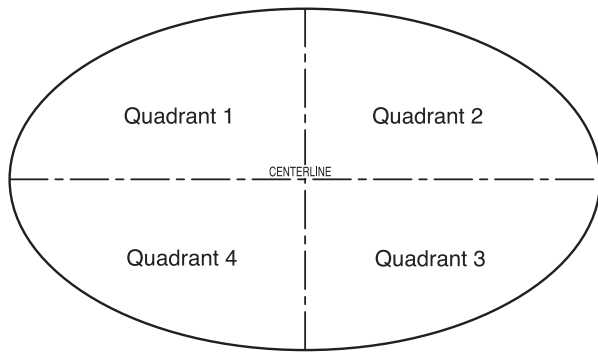

### CORNER MODELS

On a 1" thick plywood deck, place the template in the upper section noted as Section 1 in the diagram. Trace Section 1 to establish the centerline and front edge of the cutout. Flip the template along the centerline and trace to complete the other half of the unit noted as Section 2 in the diagram below.

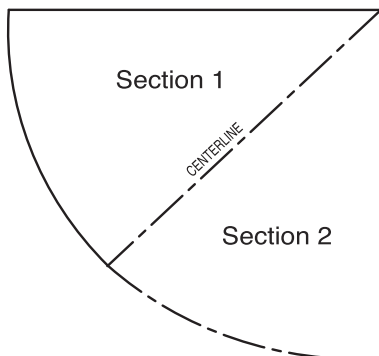

### RECTANGLE MODELS

Using a 1" thick plywood deck, the cutout should be 2" smaller than the overall tub dimensions (length & width), for 1" overhangs on all sides. For example, a 72" x 42" unit should have a deck cutout of 70" x 40". Additional dimensions can be found in the technical data sheets at [www.aquaticbath.com](http://www.aquaticbath.com).

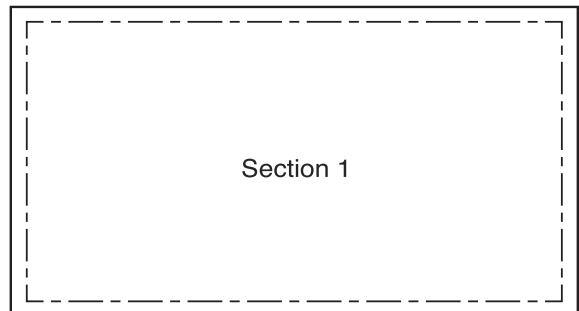

# INSTALLATION INSTRUCTIONS

## PLUMBING

1. After securing tub in place, normal waste and overflow, water spout and valves are installed per normal plumbing procedures, in accordance with all national, state and local standards.
2. Install standard 1½" trap to drain and overflow. Before proceeding, make final operational check by filling tub with water to overflow and operate pump for 5 minutes. Check for leaks carefully both while pump is running and has been turned off. Allow water to stand in tub for at least 30 minutes before draining. **AQUATIC WILL NOT BE RESPONSIBLE FOR WATER DAMAGE OF ANY KIND IN CONNECTION WITH ONE OF OUR BATHS.**
3. When selecting fill spout location, check to ensure that spout is long enough to clear the tub rim from its desired location. If installation is to be on the tub deck, check the back side of tub for adequate space for connection to water lines before drilling or cutting tub.

**NOTE:** For rough-in measurements, please refer to your tub's technical data sheet found at [www.aquaticbath.com](http://www.aquaticbath.com).

## ELECTRICAL INSTALLATION

**WARNING:** ALL ELECTRICAL CONNECTIONS SHOULD BE MADE BY A LICENSED, LOCALLY CERTIFIED ELECTRICIAN, IN ACCORDANCE WITH THE REQUIREMENTS OF THE NATIONAL ELECTRICAL CODES AND PROCEDURES.

**WARNING:** WHEN USING ELECTRICAL PRODUCTS, PRECAUTIONS SHOULD ALWAYS BE FOLLOWED, INCLUDING THE FOLLOWING:

**DANGER:** RISK OF ELECTRIC SHOCK! This unit requires two dedicated circuits, protected by a Ground Fault Circuit Interrupter (GFCI). Rough in wiring to control boxes on dedicated 120V, 15 amp, GFCI protected circuits.

GFCI's are not supplied; however we do specify their use.  
All known code authorities require GFCI's.

**ELECTRICAL:** Two GFCI protected, 120 Volt, 15 Amp, 60 Hz, circuits with a service ground is required, "dedicated" only to powering the bath.

**PLEASE NOTE:** Because the pump is housed in a plastic non-conductive housing, the pump does not need to be grounded.

**DANGER:** Risk of electric shock. Do not alter the factory installed wiring. A licensed electrician must provide the "dedicated" electrical services protected by the GFCI's. The location of the GFCI's must be accessible for regular testing. **USE COPPER CONDUCTORS ONLY.**

**CAUTION:** Before use of the pump. test the GFCI's for proper operation. The pump should turn off when the GFCI "test" button is pushed.

# INSTALLATION INSTRUCTIONS

## DRIFTBATH WITH CHROMATHERAPY LED LIGHTS

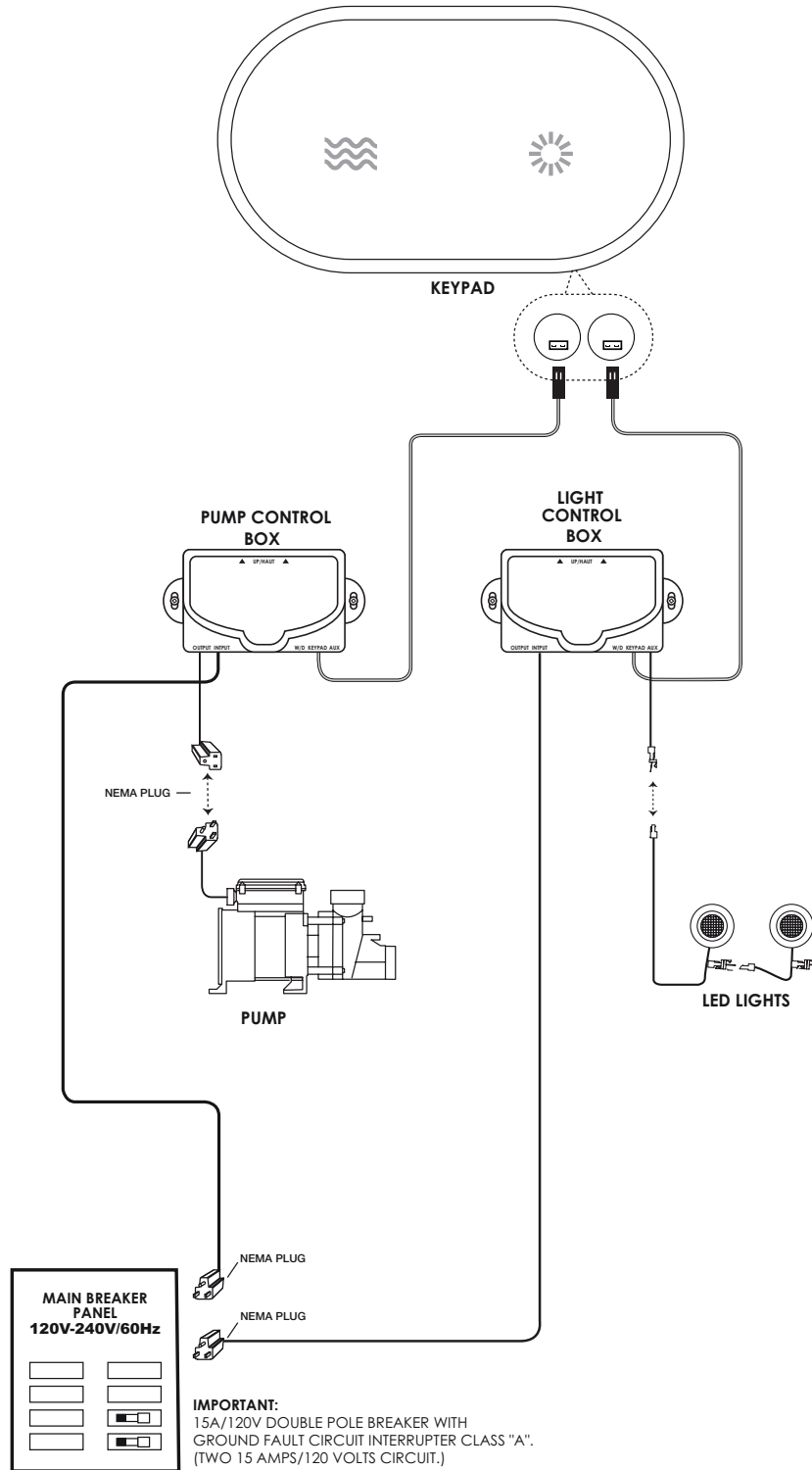

**WARNING:** All electrical connections should be made by a locally licensed electrician/technician.

# OPERATION INSTRUCTIONS

## BATH-SIDE ON/OFF CONTROLS



Keypad Functions	
1:	On/Off Pump
1st Press:	The pump starts
2nd Press:	The pump stops
2:	Chromatherapy
1st Press:	Turn on the light in white
2nd Press:	Rainbow cycle – Low speed
3rd Press:	Rainbow cycle – High speed
4th Press:	Turquoise
5th Press:	Blue
6th Press:	Magenta
7th Press:	Red
8th Press:	Orange
9th Press:	Yellow
10th Press:	Green
11th Press:	Back to Rainbow cycle – Low speed
	<i>(Press and hold 2 seconds at any time to turn off the light.)</i>
ADVANCED PROGRAMMING	
	Integrated 20 minutes pump shut-off automatic timer



Electronic Keypad

**CAUTION: BEFORE USE OF THE PUMP, TEST THE GFCI FOR PROPER OPERATION. THE PUMP SHOULD TURN OFF WHEN THE GFCI "TEST" BUTTON IS PUSHED.**

**Warning - Prolonged Immersions in Hot Water May Induce Hyperthermia**  
 Hyperthermia occurs when the internal temperature of the body reaches a level several degrees above the normal body temperature of 98.6°F. The symptoms of hyperthermia include an increase in the internal temperature of the body, dizziness, lethargy, drowsiness, and fainting. The effects of hyperthermia include (1) failure to perceive heat, (2) failure to recognize the need to exit the tub, (3) unawareness of impending hazard, (4) fetal damage in pregnant women, (5) physical inability to exit the tub, (6) unconsciousness resulting in the danger of drowning.

**WARNING - THE USE OF ALCOHOL, DRUGS, OR MEDICATION CAN GREATLY INCREASE THE RISK OF FATAL HYPERTHERMIA.**

# TUB CARE

## MAINTENANCE

### DriftBath Cleaning

Before tub is used, remove all debris and clean tub. **DO NOT USE ABRASIVE CLEANERS ON THE ACRYLIC FINISH.** Use a non-abrasive detergent and rinse well after cleaning.

- Fill the tub with HOT water to a level 2" above the highest water port.
- Add 4-6 tablespoons of low-sudsing automatic liquid dishwashing detergent and no more than 24-48 ounces of regular household bleach to the water (do not use splashless bleach).
- Operate tub for 10 minutes. Drain.
- Refill with cold water and operate tub for 5 minutes. Drain.

**NOTE:** DO NOT USE OIL OR OIL BASED BATH ADDITIVES. If you want to use any kind of bath additive, use only a small amount of low-foaming powder or crystal substance; the DriftBath action may intensify the foaming properties of soaps. The use of certain bubble baths and bath additives may increase the level of accumulations of bath residue in the DriftBath system. If excess accumulations persist, you should discontinue use of these products. Bath salts and Epsom salts are ok.

If you have followed the monthly purging instructions and still have an excess accumulation of bath residue and desire an alternative cleaning mechanism, we recommend SUPER SYSTEMS CLEAN PLUS manufactured by Stearns Packaging Corporation to rectify this condition. This may be obtained by calling Aquatic, at (800) 945-2726. It is recommended that you follow the instructions provided by the manufacturer with the product. Repeated use may be necessary. SUPER SYSTEMS CLEAN PLUS does not replace the necessity to purge your DriftBath system at least once a month with a low foaming detergent and bleach.

### Surface Cleaning

Use common household, non-abrasive cleaners for most cleaning jobs. Rinse well and dry with a clean cloth. Never use abrasive cleaners. Do not allow your Lucite® acrylic surface to come into contact with products such as acetone (nail polish remover), nail polish, dry cleaning solution, lacquer thinners, gasoline, pine oil, etc. Remove dust with a soft, dry cloth. Clean grease, oil, paint, and ink stains with isopropyl (rubbing) alcohol.

### Surface Scratch Removal

Minor scratches may be removed by polishing your tub with a non-abrasive car polish, followed by buffing. Deeper scratches can be removed by:

- Sanding with wet 400 grit sandpaper.
- Sanding with wet 600 grit sandpaper.
- Sanding with wet micro-grit sandpaper.
- Buffing out using car polish.

**CAUTION:** Do not wax/polish the bottom interior of the tub, as it can become slippery.

## REPAIR

The installation and service of your bath should be performed only by a qualified service technician. Remember when contacting your dealer always have your serial number, proof of purchase and model number available. This will ensure a quick response on warranty items. The model and serial numbers are located above the pump on the backside of the tub.

**NOTE:** ALL WARRANTY REPAIRS MUST BE AUTHORIZED BY AQUATIC BEFORE WORK IS STARTED. FOR SERVICE, ALWAYS CONTACT YOUR DEALER.

**CAUTION:** Care should be taken to prevent inappropriate chemicals coming in contact with the Lucite® acrylic surface. Please read and observe all instructions and/or warnings on containers containing substances you contemplate applying to your tub. Any failure to comply may void your warranty.

# WATER QUALITY

## CHEMICAL & WATER QUALITY

Owners of fill and drain whirlpool bathtubs need to know basic information concerning water quality, how it affects the performance and enjoyment of the operation of their tubs, and steps that can be taken by the owner to correct related problems. Important issues are the microbiological and chemical quality of the water.

### 1. Microbiological Quality

Microbes are present in water supplied by individual wells or water systems and even in the air around us. These microbes are usually in amounts below what is noticeable. Microbes from the water or air or from a bather's body may settle on wet surfaces such as bathtub surface or piping system where they can grow in numbers. With regards to whirlpool bathtubs, brown/black fungi/mold or pigmented (colored) bacteria can be noted.

**Fungi/Mold** - Fungi and mold are always present. Usually the levels are such that we don't notice them. When moisture and temperature are sufficient, the organisms will grow to levels that we may smell and/or see. The best examples of such growth is the very common black growth on the bottom of shower curtains. The best solution to keep these surfaces free from fungi/mold growth is frequent cleaning.

**Pigmented Bacteria** - A pinkish substance may appear on bathroom fixtures that is very persistent, appearing in the shower, sink and along the water line of toilet bowls. The residue is less likely a problem associated with water quality than with naturally occurring airborne bacteria. The bacteria may produce a pinkish film, and sometimes a dark gray film, on surfaces that are regularly moist, including toilet bowls, shower heads, sink drains, and tiles. The problem is more common in humid areas of the country. In any particular case, the determination of the exact species of bacteria causing the problem would require lengthy and costly laboratory testing; however, most experts believe the bacteria responsible is *Serratia Marcescens*. These bacteria thrive on moisture, dust and phosphates, and are widely distributed in soil, food and also in animals. The best solution to keep these surfaces free from the bacterial film is continual cleaning. A chlorine containing compound is the best cleaner. Avoid abrasives to limit scratching fixtures, which will make them even more susceptible to bacteria.

### 2. Chemical Quality

The water supplied by individual wells or water systems always contains chemicals, usually in amounts below those which the consumer would notice. Examples of such chemicals, which are of potential concern for the owners of whirlpool bathtubs, are calcium and magnesium salts, copper, iron, manganese and sulfates. When these chemicals are present in sufficient amounts, they may cause problems in whirlpool bathtubs. You should contact your water supply or treatment company and follow their suggestions for treatment.

**Calcium and Magnesium Salts** - Collectively, the various compounds of calcium and/or magnesium are referred to as salts. Calcium and magnesium salts are often found in ground water supplies and cause "hardness" in water. Hard and soft water are relative terms. Hard water retards the cleaning action of soaps and detergents, causing expense in the form of extra work and cleaning agents. When hard water is heated, it will deposit a hard scale. With regard to whirlpool bathtubs, high calcium and/or magnesium levels may result in the formation of white stains and scale formation on the inside of the tubs, especially noticeable with colored tubs. If this occurs, you need to contact the water supplier to determine the calcium and/or magnesium content and/or corrosion potential of the water and follow their suggestions for treatment. If your water supply is generated from a well, you need to contact a water treatment company to test your water and suggest solutions if a problem is present.



## WATER QUALITY

**Iron** - Iron is found in many natural waters especially from wells. Iron in water can also result from the corrosion of piping in the water supply system, such as cast iron mains or galvanized steel service lines, or galvanized piping in the home water system. High iron levels may result in the formation of brown stains in the vicinity of the faucet outlets of various fixtures in the home. With whirlpool bathtubs, the staining may be particularly pronounced because the aeration action can oxidize iron to a form that settles out on the inside of the tubs, especially noticeable with white tubs. If high iron in the water is present, you can also notice rust colored deposits inside your toilet tank or dishwasher. If this occurs, you need to contact the water supplier to determine the iron content and/or corrosion potential of the water and follow their suggestions for treatment. If your water supply is generated from a well you need to contact the water treatment company to test your water and suggest solutions if a problem is present.

**Manganese** - Manganese is found in many natural waters especially from wells. High manganese levels may result in the formation of small black particles that can stain laundry, especially noticeable with whites such as sheets or towels. With whirlpool bathtubs, the formation of small black particles may be particularly pronounced because the aeration action in the tub can oxidize manganese to an insoluble form that is especially noticeable with white tubs. If high manganese in the water is present, you may also notice black stains on white laundry. If this occurs, you need to contact the water supplier to determine the manganese content of the water and follow their suggestions for treatment. If your water supply is generated from a well, you need to contact a water treatment company to test your water and suggest solutions if a problem is present.

### 3. Treatment

If you have contacted your water supplier and followed their instructions and you are still having problems, you need to increase the frequency of cleaning with low-foaming detergent/bleach starting from monthly purging down to using it every other day as required to eliminate your particular problem. The use of certain bath oils, bubble bath soaps and bath additives may increase the level of accumulations of bath residue in the whirlpool system. More frequent cleaning may be necessary if these products are used in the whirlpool tub. If excess accumulations persist, you should discontinue the use of these products. If you have followed the monthly purging instructions and still have an excess accumulation of bath residue and desire an alternative cleaning mechanism, we recommend **SUPER SYSTEMS CLEAN PLUS** (Aquatic Part #ST1010) manufactured by Stearns Packaging Corporation to rectify this condition. This may be obtained by contacting Aquatic at (800) 945-2726. It is recommended that you follow the instructions provided by the manufacturer with the product. Repeated use may be necessary. **SUPER SYSTEMS CLEAN PLUS** does not replace the necessity to purge your whirlpool system at least once a month with a low foaming detergent and bleach.

# TROUBLESHOOTING GUIDE

**WARNING:** Always turn off power at the main electrical service panel when servicing your tub.

SYMPTOMS	POSSIBLE PROBLEMS	SUGGESTED SOLUTIONS
Motor does not start	<ol style="list-style-type: none"> <li>1) GFCI or circuit breaker in OFF position.</li> <li>2) Fuses blown or thermal overload open.</li> <li>3) Locked motor shaft.</li> <li>4) Motor windings burned out.</li> <li>5) Defective starting switch inside single-phase motor.</li> <li>6) Disconnected or defective wiring.</li> <li>7) Low voltage.</li> </ol>	<ol style="list-style-type: none"> <li>1) Reset GFCI (if optional heater is installed, be sure there are two GFCI circuits.)</li> <li>2) Contact your electrician.</li> <li>3) Contact Aquatic.</li> <li>4) Contact Aquatic.</li> <li>5) Contact Aquatic.</li> <li>6) Check and reconnect if needed.</li> <li>7) Contact your electrician.</li> </ol>
Motor does not reach full speed:	<ol style="list-style-type: none"> <li>1) Low voltage.</li> <li>2) Wiring too small.</li> </ol>	<ol style="list-style-type: none"> <li>1) Contact your electrician.</li> <li>2) Contact your electrician.</li> </ol>
Motor overheats (protector trips):	<ol style="list-style-type: none"> <li>1) Low voltage.</li> <li>2) Inadequate ventilation.</li> <li>3) Wiring too small.</li> </ol>	<ol style="list-style-type: none"> <li>1) Contact your electrician.</li> <li>2) Refer to installer/dealer.</li> <li>3) Contact your electrician.</li> </ol>
Pump delivers no water	<ol style="list-style-type: none"> <li>1) Leakage of air into suction system.</li> <li>2) Impeller clogged.</li> </ol>	<ol style="list-style-type: none"> <li>1) Check suction screen for clogs.</li> <li>2) Clean and unlog.</li> </ol>
Low pump capacity	<ol style="list-style-type: none"> <li>1) Suction or discharge line partly plugged.</li> <li>2) Pump running at reduced speed.</li> <li>3) Impeller clogged.</li> </ol>	<ol style="list-style-type: none"> <li>1) Clean and unlog.</li> <li>2) See "Motor does not reach full speed."</li> <li>3) Clean and unlog.</li> </ol>
Noisy pump and motor	<ol style="list-style-type: none"> <li>1) Worn motor bearings.</li> <li>2) Pumps touching a stationary object.</li> <li>3) Suction line partly plugged.</li> <li>4) Pump not supported properly.</li> <li>5) Low voltage</li> </ol>	<ol style="list-style-type: none"> <li>1) Contact Aquatic.</li> <li>2) Refer to installer/dealer.</li> <li>3) Clean and unlog.</li> <li>4) Contact Aquatic.</li> <li>5) Contact electrician.</li> </ol>
Lights do not turn on	<ol style="list-style-type: none"> <li>1) GFCI or circuit breaker in OFF position</li> <li>2) Fuses blown or thermal overload open</li> <li>3) Disconnected or defective wiring</li> <li>4) Low voltage</li> </ol>	<ol style="list-style-type: none"> <li>1) Reset GFCI.</li> <li>2) Contact your electrician.</li> <li>3) Check and reconnect if needed.</li> <li>4) Contact your electrician.</li> </ol>
Leakage of water at shaft	<ol style="list-style-type: none"> <li>1) Shaft seal requires replacement.</li> </ol>	<ol style="list-style-type: none"> <li>1) Contact Aquatic</li> </ol>
Leaking unions	<ol style="list-style-type: none"> <li>1) O-ring missing or damaged.</li> <li>2) Plumbing in a bind.</li> <li>3) Loose unions.</li> </ol>	<ol style="list-style-type: none"> <li>1) Contact Aquatic</li> <li>2) Contact Aquatic</li> <li>3) Tighten unions.</li> </ol>
Vibration noise	<ol style="list-style-type: none"> <li>1) Tub or tub plumbing is touching tile/wall.</li> <li>2) Pump is touching framing.</li> </ol>	<ol style="list-style-type: none"> <li>1) Refer to installer/dealer.</li> <li>2) Refer to installer/dealer.</li> </ol>

# REPLACEMENT PARTS MAP

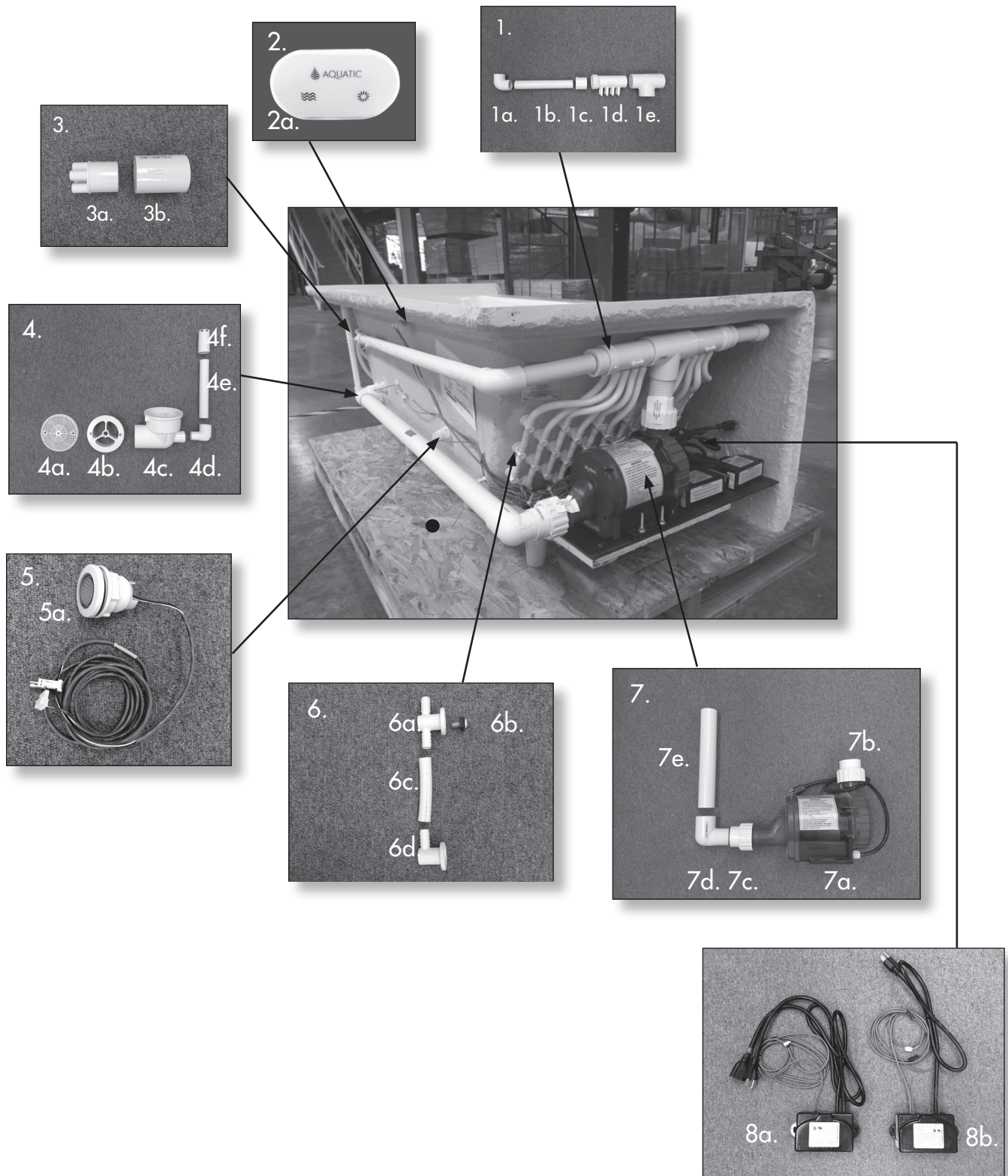

## REPLACEMENT PARTS LIST

ILLUSTRATION NO.	PART #	DESCRIPTION
1A.	8406010FTG	1" 90 DEG SLIP ELBOW
1B.	8100PIPE	1" PVC PIPE
1C.	8437211FTG	1.5" X 1" REDUCER FITTING
1D.	8500MANIFOLD	DRIFTBATH MANIFOLD; 8 PORT
1E.	8401015FTG	TEE FITTING; 1.5"S X 1.5"S X 1.5"S
2A.	8500PADCL	KEYPAD KIT;TMS TIMER/LIGHT; CL
3A.	5982MANIFOLD	MANIFOLD; 4 PORT
3B.	8429010FTG	1" COUPLING FITTING
4A.	1127WH / BI	120GPM SUCTION ASSEMBLY; LO-PRO;WH or BI
4B.	(PACKAGED WITH 4A.)	SUCTION WALL FITTING (DRIFTBATH)
4C.		1.5" SUCTION ELBOW (DRIFTBATH)
4D.	8409005FTG	0.5" 90 DEG ST ELBOW
4E.	8050PIPE	0.5" PVC PIPE
4F.	1119SLIP	1.5" POP CHECK VALVE
5A.	8112LIGHTWH / BI	9 LED HIGH BRIGHT LIGHT;WH or BI
6A.	1106TFIT	T FITTING W/ WASHER"
6B.	1100WH / BI	DRIFTBATH INJECTOR;WH or BI
6C.	8500HOSE	HOSE; 3/8" X 9/16" WHITE VINYL
6D.	1105LFIT	L FITTING W/ WASHER
7A.	8500MOTOR	0.75HP 115V/60HZ DRIFTBATH PUMP
7B.	(PACKAGED WITH 7A.)	1.5" PUMP UNION W/ 40MM ADAPTER
7C.		1.5" PUMP UNION W/ 50MM ADAPTER"
7D.	8409015FTG	1.5" 90 DEG ST ELBOW
"7E.	8150PIPE	1.5" PVC PIPE"
"8A.	8501CONTROL	CONTROL BOX;TMS;W/P ON/OFF"
"8B.	8500CONTROL	CONTROL BOX; CHROMATHERAPY 120V"
10D. (OPTION)	8020LIGHTS	20LEDS CHROMATHERAPY BULB
11	8160BOX	CONTROL BOX;TMS;W/P ON/OFF CNFG;120V



## Aquatic Limited Warranty Serenity DriftBath™

### Limited Warranty For Original Consumer For Household Usage

#### WHAT PRODUCTS ARE COVERED

Structures and surface finishes on the tub and their support systems including equipment, components, attachments and plumbing equipment. Different warranty periods apply to specific components.

#### Warranty Periods for Specific Components

##### 10 YEAR STRUCTURAL WARRANTY FOR TUB SHELL

Aquatic extends to the original consumer purchaser (the "Purchaser") of the acrylic, fiberglass reinforced shell of tubs a limited warranty that the shell will retain its structural integrity and configuration and be free of water loss due to a defect in the tub shell for a period of 10 years from the date of purchase or 11 years from date of manufacture. This limited structural warranty does not apply to attachments to the acrylic, fiberglass reinforced shell, such as plumbing, fittings and other apparatus; this support equipment pieces is covered below.

##### 10 YEAR SURFACE WARRANTY FOR FACE OF TUB

The interior surface/face of a tub is warranted against fading, blistering, cracking and delamination due to defects in the surface materials for a period of 10 years from the date of purchase or 11 years from date of manufacture. This surface warranty extends to defects due to surface material mixing or molding. This surface warranty does not apply to fading, cracking, delamination or blistering due to excessive wear, sun fading or scouring due to cleaning.

##### 2 YEAR EQUIPMENT WARRANTY FOR SUPPORT EQUIPMENT, COMPONENTS, CONTROLS & PLUMBING EQUIPMENT

All support equipment, components, controls and plumbing equipment on tubs are warranted for 2 years from date of purchase or 3 years from date of manufacture, against defects in workmanship and materials. Fuses and pillows are not included in this limited warranty.

#### EXCLUSIVE REMEDY

Aquatic shall, as its sole obligation, and Purchaser's sole and exclusive remedy for any breach of the limited warranty set forth herein, repair or replace the affected components of any defective tub. If Aquatic determines that repair or replacement of the entire defective tub is not commercially practicable, Aquatic may accept return of the tub and refund the then-current list price of the tub (or, if the tub has been discontinued, of the most nearly comparable current product) to Purchaser for the defect. Any repair, replacement or warranty service by Aquatic hereunder will not extend the applicable warranty periods set forth herein. Unless otherwise agreed upon by Aquatic in writing, Purchaser will bear the costs of access, de-installation, re-installation and transportation of the tub to Aquatic and back to Purchaser.

#### WHAT YOU MUST DO

To obtain warranty service under these warranties:

1. You must be the Purchaser of the tub.
2. You must give prompt notice to Aquatic of any defect claim within the warranty period and provide us with any substantiation that we may reasonably request.  
Contact: Warranty Service 800.945.2726 • aquaticbath.com.
3. Tubs must have been installed and maintained in accordance with standard industry practice and with Aquatic's instructions contained in the Owner's Manual and Installation Guide. Please contact Aquatic at the address stated above to obtain a copy of Aquatic's Owner's Manual and Installation Guide.

#### EXCLUSIONS

These limited warranties are null and void if:

1. The tub is subject to damage during shipping by carriers, faulty installation, maintenance, abuse, accident or other damages.
2. The tub is installed outdoors.
3. The tub is not installed in accordance with standard industry practice and Aquatic's instructions contained in the Owner's Manual and Installation Guide.  
Please contact Aquatic at the address stated above to obtain a copy of Aquatic's Owner's Manual and Installation Guide.
4. Unreasonable use of the tub occurs (including any use for non-bathing purposes or failure to provide reasonable and necessary maintenance as specified in Aquatic Owner's Manual and Installation Guide supplied with the tub).
5. The tub is altered, customized, or modified without Aquatic's prior written approval.

#### LIMITATIONS

1. Aquatic tubs sold to Purchasers for industrial, commercial or hotel use are warranted for two years from the original date of purchase or 3 years from date of manufacture, with a limited warranty that the shell will retain its structural integrity and configuration and be free of water loss due to a defect in the tub. The interior surface/face of the tub is warranted against fading, blistering, cracking and delamination due to defects in the surface materials. All support equipment, components, controls and plumbing equipment sold to Purchasers for industrial, commercial or hotel uses on the support equipment, controls, or plumbing is warranted for 1 year from date of purchase or 2 years from date of manufacture. Fuses and pillows are not included in this limited warranty. Aquatic reserves the right to furnish a substitute or replacement tub component in the event the tub component is discontinued or otherwise unavailable.
2. THESE WARRANTIES ARE NON-TRANSFERABLE TO ANY OTHER PURCHASER OR PARTY OTHER THAN THE PURCHASER. NO OTHER AGENT OR PARTY CAN GIVE ANY OTHER WARRANTY OR PROMISE. THIS IS THE SOLE WARRANTY FOR YOUR AQUATIC TUB.
3. Building Code Compliance is not covered by this limited warranty. Local building codes vary considerably, the Purchaser of the tub is responsible for checking with local building or plumbing contracts to insure local code compliance before installation.
4. Your warranty period starts (begins to run) at the earlier of 1) the beginning of installation of your tub in a home, or 2) the purchase of your tub, and shall never exceed 11 years from the date the tub is manufactured for its shell or finish, or 3 years from the manufacture of plumbing supplies and accessories.

#### GENERAL

EXCEPT FOR THE LIMITED WARRANTIES SET FORTH ABOVE, THE TUBS ARE PROVIDED "AS IS" WITHOUT ANY REPRESENTATIONS OR WARRANTIES OF ANY KIND. AQUATIC EXPRESSLY DISCLAIMS ALL OTHER WARRANTIES, EXPRESS, IMPLIED, INCLUDING BUT NOT LIMITED TO ANY WARRANTIES OF MERCHANTABILITY, FITNESS FOR A PARTICULAR PURPOSE, TITLE, AND NON-INFRINGEMENT OF THIRD PARTY RIGHTS. AQUATIC DOES NOT WARRANT THAT THE TUBS FURNISHED HEREUNDER WILL MEET PURCHASER'S REQUIREMENTS OR THAT THE OPERATION OF THE PRODUCT WILL BE UNINTERRUPTED OR DEFECT-FREE OR THAT ALL DEFECTS WILL BE CORRECTED. PURCHASER ACKNOWLEDGES THAT IT HAS RELIED ON NO WARRANTIES OTHER THAN THE EXPRESS WARRANTIES PROVIDED HEREIN.

IN NO EVENT WILL AQUATIC BE LIABLE FOR ANY INDIRECT, SPECIAL, INCIDENTAL, EXEMPLARY OR CONSEQUENTIAL DAMAGES; INCLUDING WITHOUT LIMITATION ANY LOST PROFITS AND COSTS OF PROCUREMENT OF SUBSTITUTE PRODUCT, ARISING OUT OF OR RELATED TO A BREACH OF THIS LIMITED WARRANTY.

Some states do not allow exclusions or limitations on implied warranties. Thus, the above exclusions or limitations may not apply. This warranty gives you specific legal rights. Purchaser may also have other rights which may vary from state to state.







**AQUATIC**

The bath people

Customer Service: 800.945.2726 • [aquaticbath.com](http://aquaticbath.com)



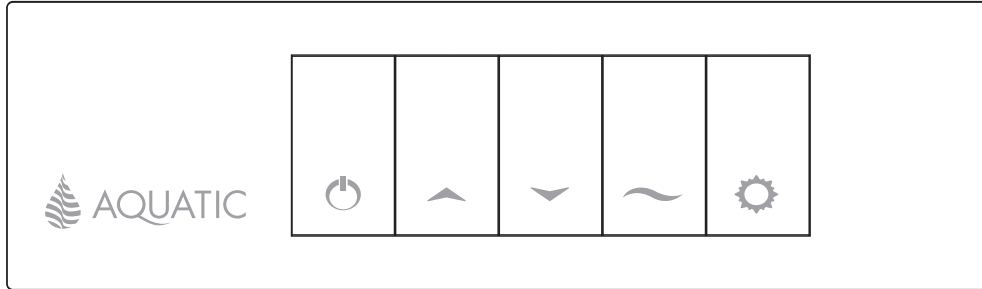

- 1 ON/OFF BLOWER
  - 1<sup>st</sup> Press: The blower starts
  - 2<sup>nd</sup> Press: The blower stops
- 2 BLOWER SPEED VARIATION +
  - Press & hold to increase the blower speed
  - Release pressure at the desired speed
- 3 BLOWER SPEED VARIATION -
  - Press & hold to decrease the blower speed
  - Release pressure at the desired speed
- 4 PULSATION MODES
  - 1<sup>st</sup> Press: Wave - Speed will vary gradually from maximum to minimum
  - 2<sup>nd</sup> Press: Pulse - Speed will go directly to minimum and then straight back to maximum
  - 3<sup>rd</sup> Press: Returns to maximum speed
- 5 ON/OFF LIGHT
  - 1<sup>st</sup> Press: Light ON - WHITE
  - 2<sup>nd</sup> Press: Light OFF
  - Turn OFF and ON within 3 seconds the light will change to:
    - SLOW - RAINBOW CYCLE;
    - FAST - RAINBOW CYCLE;
    - TURQUOISE;
    - BLUE;
    - MAGENTA;
    - RED;
    - ORANGE;
    - YELLOW;
    - GREEN;
  - return to SLOW RAINBOW CYCLE.

DRYING CYCLE OPTIONS

STANDARD DRYING CYCLE

An automatic drying cycle will start 20 minutes after the blower is turned off.

STANDARD DRYING CYCLE WITH WATER DETECTORS

They activate a drying cycle 20 minutes after the bathtub is emptied and thus even when the blower was not used.

24H PROGRAMMABLE DRYING CYCLE

The system must be stopped prior to activation or deactivation.

**Activation:** Determine at which time you wish the purge to activate.

At that precise time, press and hold the second button on the keypad for 5 seconds. The purge cycle will now start at the programmed time every 24 hrs. In the event of a power failure the program will be automatically deactivated.

**Deactivation:** press and hold the second button on the keypad for 5 seconds.

