

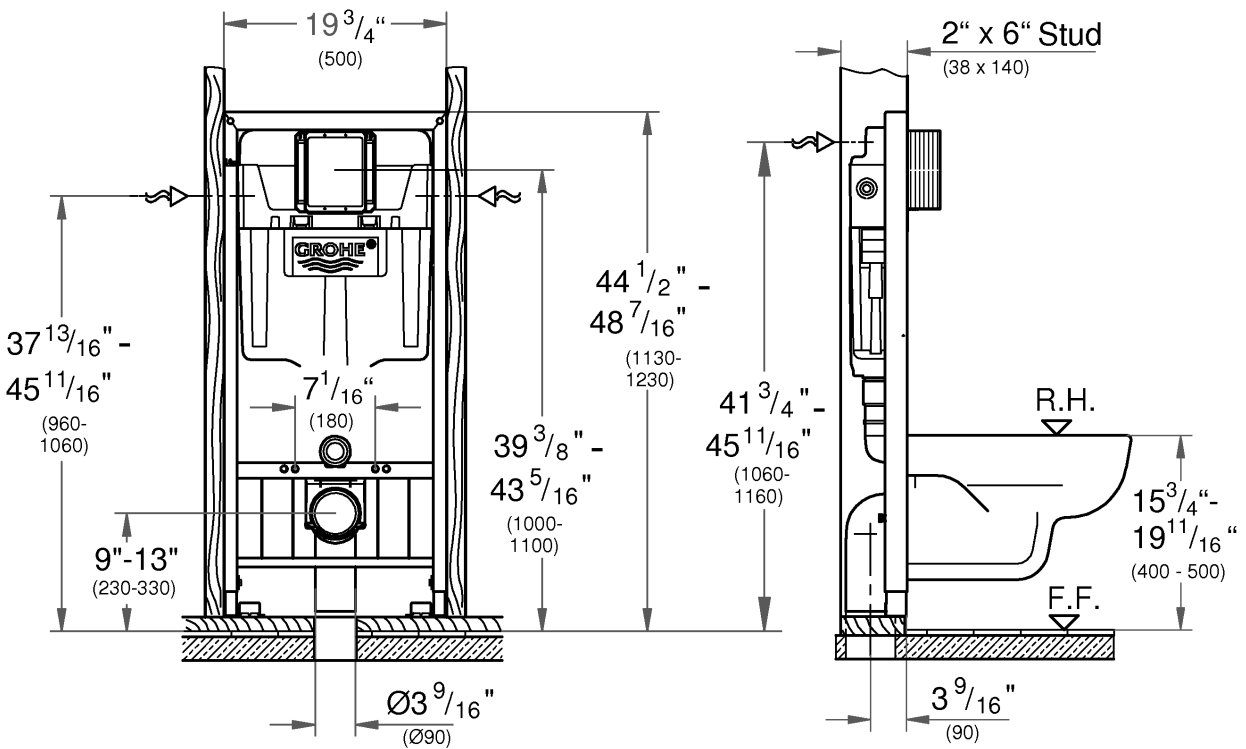

38 749

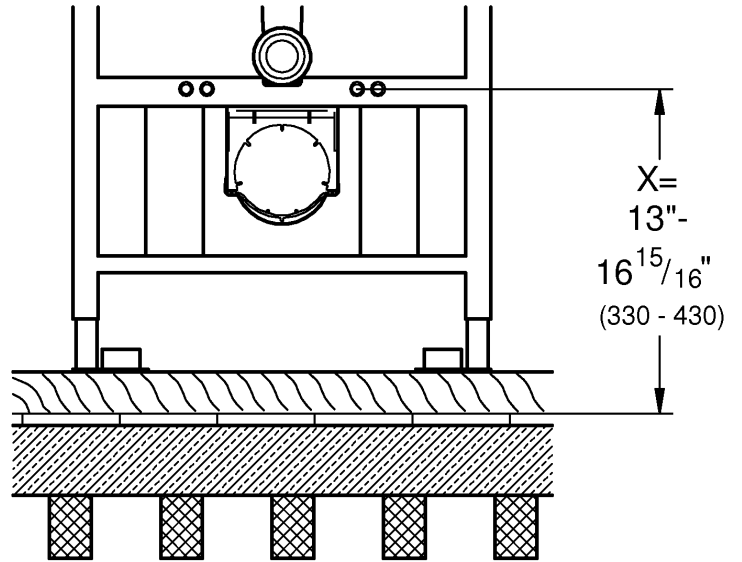
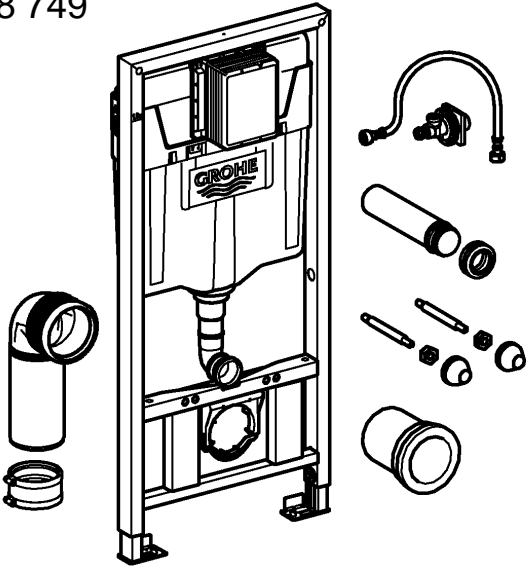

**Concealed Tank and Carrier**

The GROHE concealed water closet tank and carrier are adjustable for bowl rim height 15<sup>3</sup>/<sub>4</sub>" to 19<sup>11</sup>/<sub>16</sub>" to be used with an IAPMO listed 1.6 GPF wall hung bowl. Requires 1/2" water supply and 3" nominal outlet.

In compliance with:  
 A 112.6.2

Note that some wall hung toilets are delivered with their own mounting set which should be used if possible.

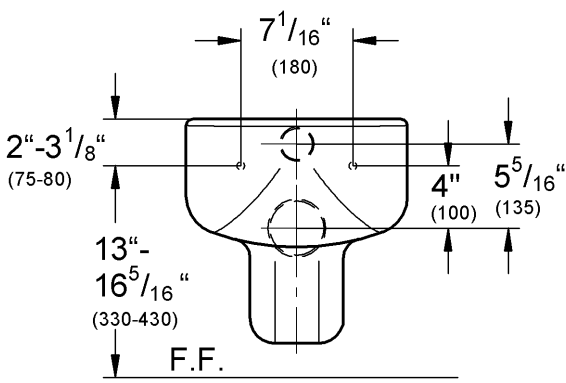

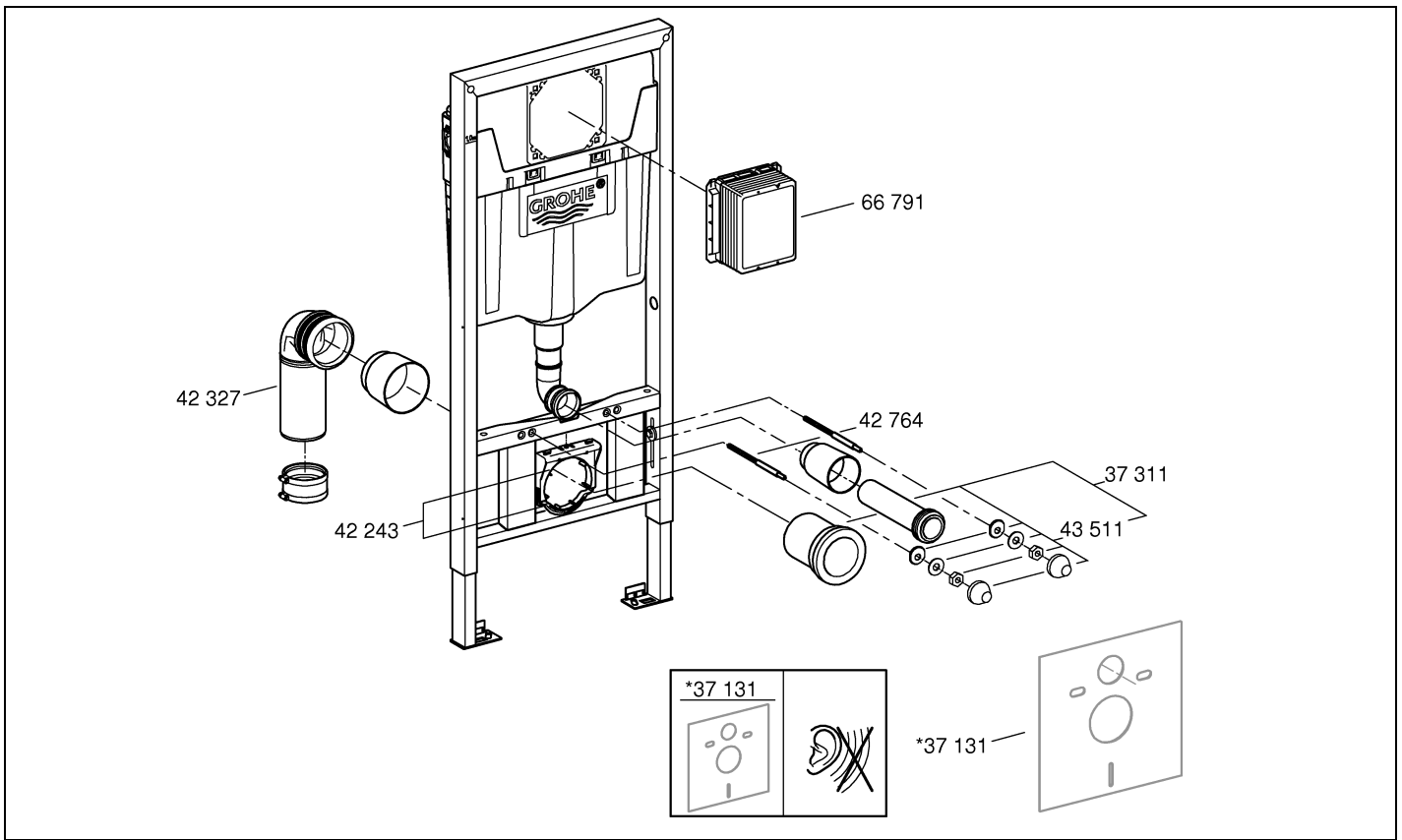

The tank and carrier are designed to fit within a 2" x 6" wood frame (or equal) construction. The studs must be placed 19 11/16" apart at the location where the unit will be positioned prior to installation into the wall. The carrier legs must be adjusted for the finished rim height of the water closet bowl. The dimensions may be taken from the bowl or from the specification sheet. Be sure to allow for finished floor covering.

**Finished rim height must be determined prior to installation.**

**NOTE:** The 2" x 6" frame work must be affixed firmly to the floor and ceiling for a safe installation. An opening of 5 1/2" x 7 1/2" must be provided on finished wall for access into the tank and placement of actuator panel and panel frame.

**STEP 1:** Locate studs as specified, and secure with additional nails. Insure rough openings are proper, plumb, and square.

**STEP 2:** Position the carrier unit in the prepared opening. **The metal frame must be flush with the face of the surrounding studs** so that maximum support for the later applied drywall is accomplished. With the unit still in place, mark all anchor hole locations on hole plate and studs. Also mark the location for the 3" DWV discharge pipe. At the same time indicate the position for the water supply, either from the top or rear into the tank.

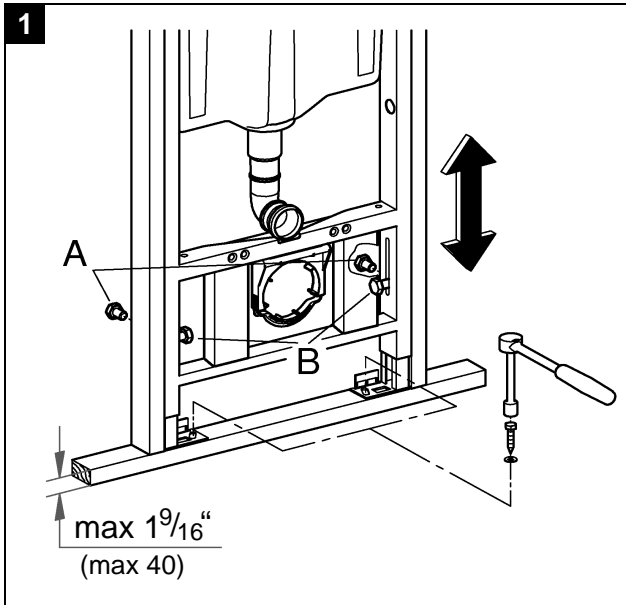

**STEP 3:**

Drill two (2) pilot holes (3/16") for the supplied lag screws where marked on floor plate, see fig. [1]. Unscrew bolts (A, B) and pull out carrier unit from framework. Adapt framework to the height of the floor structure and pull tight bolts (A), then bolts (B).

Also drill two bolt holes (1 1/32") where marked on framework, see fig. [2].

For the fixture discharge pipe bore a 4" hole 3 3/8" from front edge of plate to center through plate and floor.

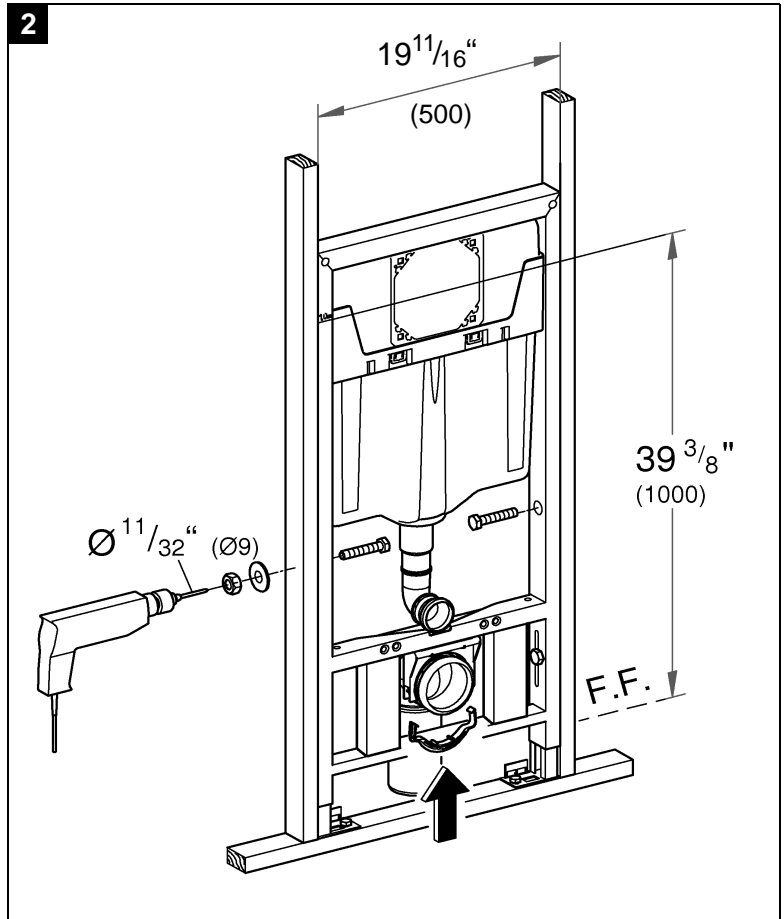

**STEP 4:** Install 3" DWV waste pipe through floor and connect to waste line (i.e. PVC, copper, cast iron).

**STEP 5:** Set carrier unit back in place into the wall frame and bolt in place with hardware provided.

**STEP 6:** Complete waste elbow connection with 3" DWV flex coupling to waste line.

**STEP 7:** Remove the middle part of the cross bar. Install shutoff valve and mud guard in the tank opening.

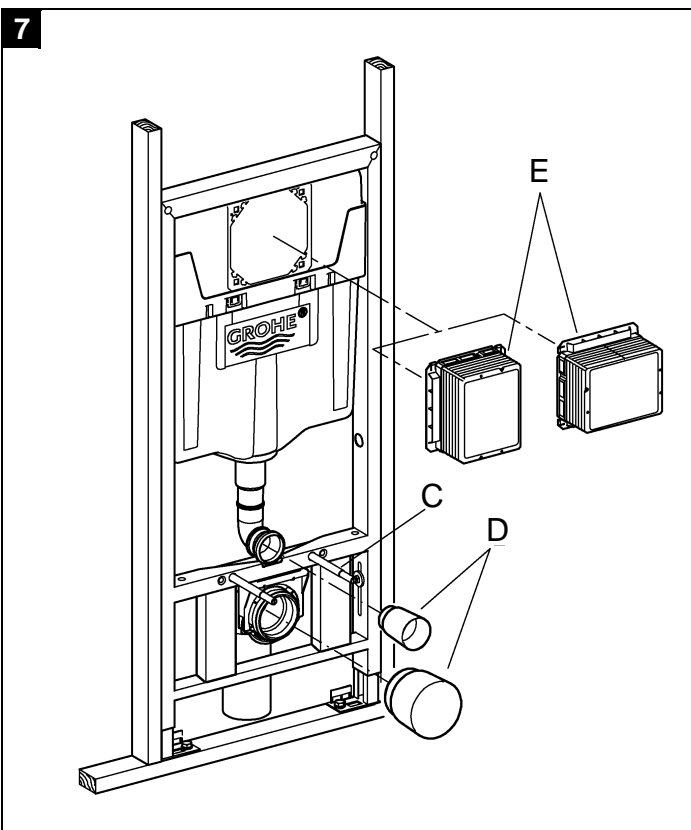
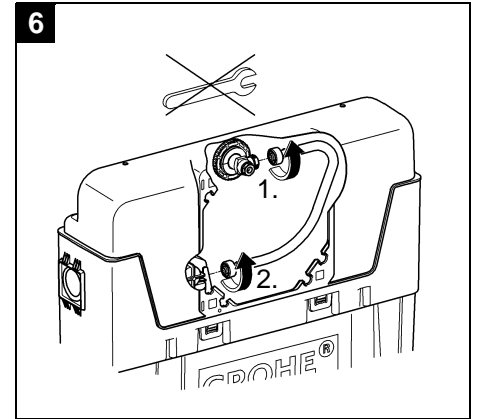
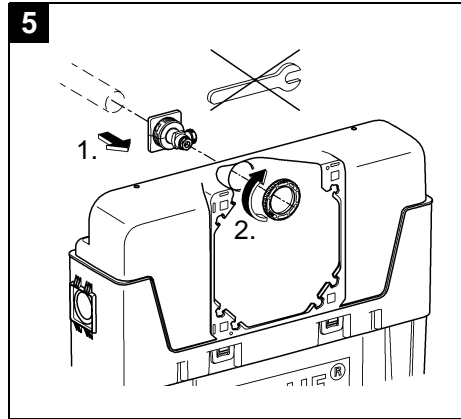
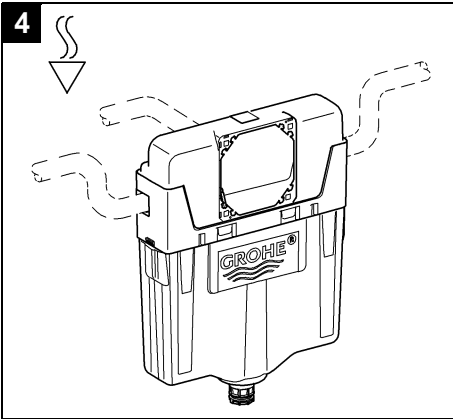
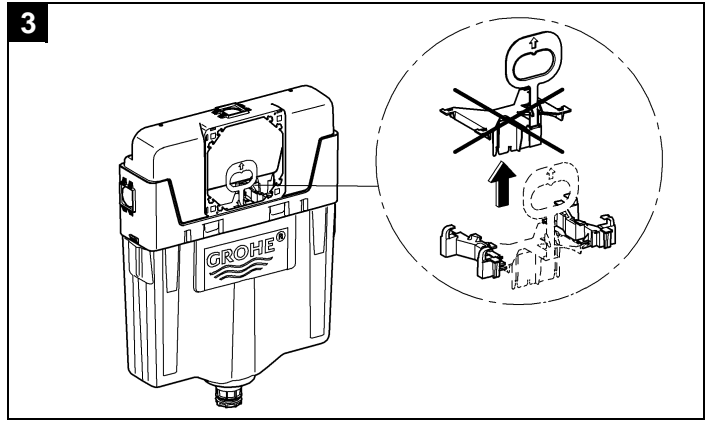

**STEP 8:** Install two 1/2" x 6" fixture support rods with plastic sleeves (C), the pipe caps (D) and mud guard (E) are mounted for protection during wall surface construction, see fig. [7].

**STEP 9:** FiberBond wallboard, 1/2" tile backer board or plywood with a ceramic tile surface would be most suitable materials recommended for wall finish in order to support the wall hung toilet bowl. Holes in wallboard for ceramic bolts must be 1" (25).

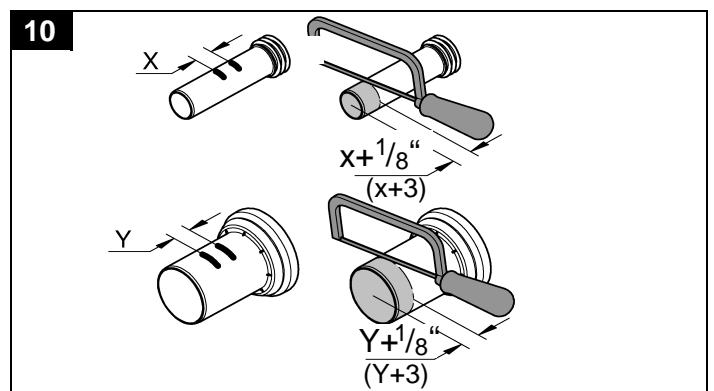
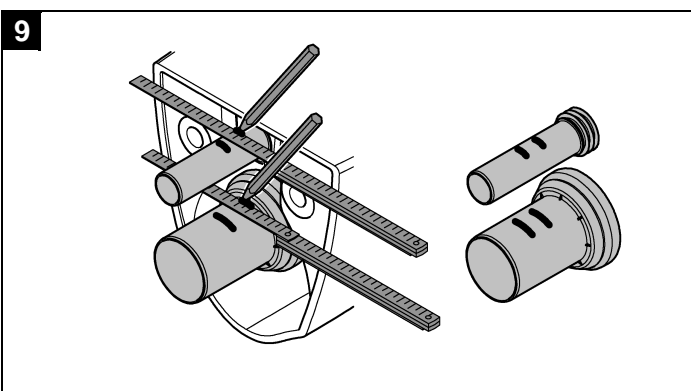
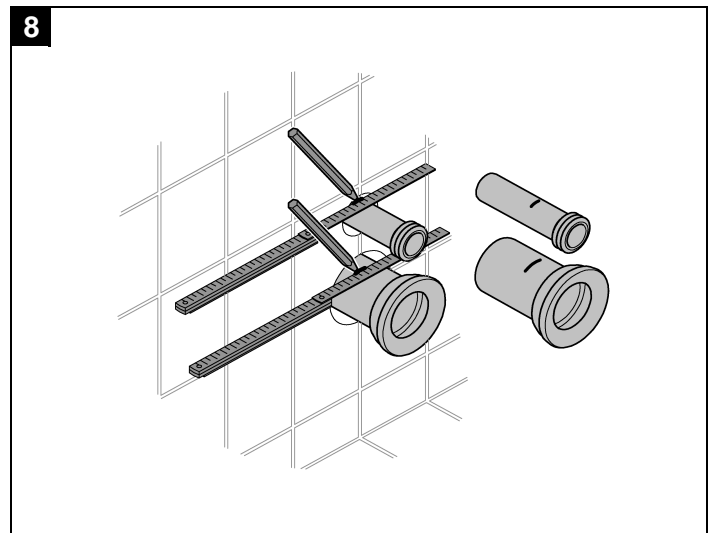

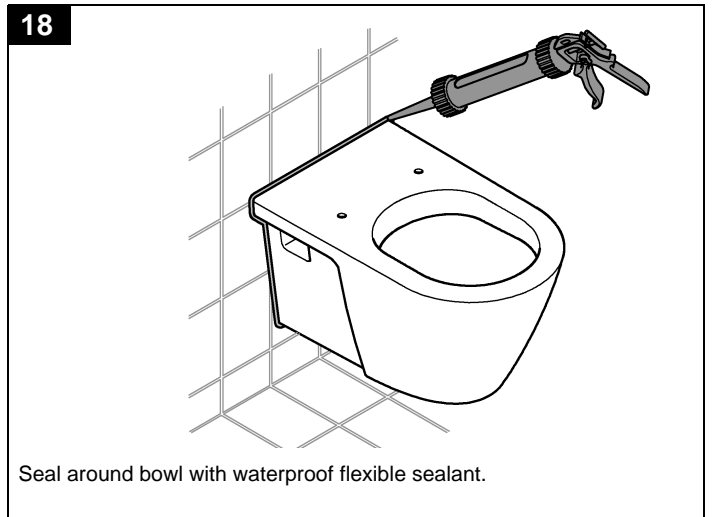
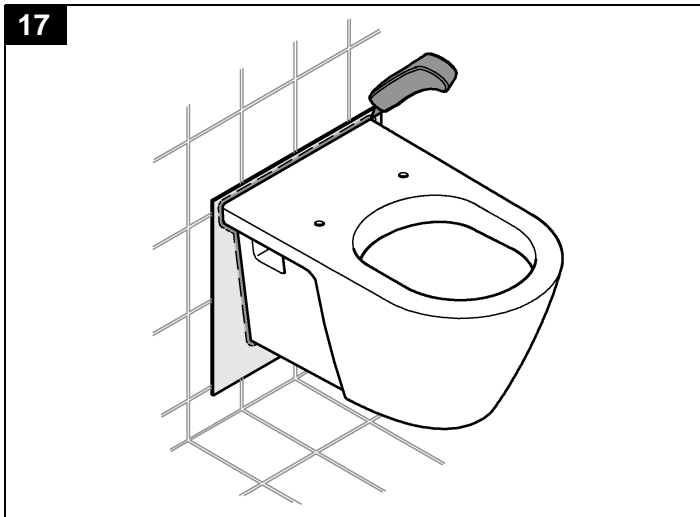
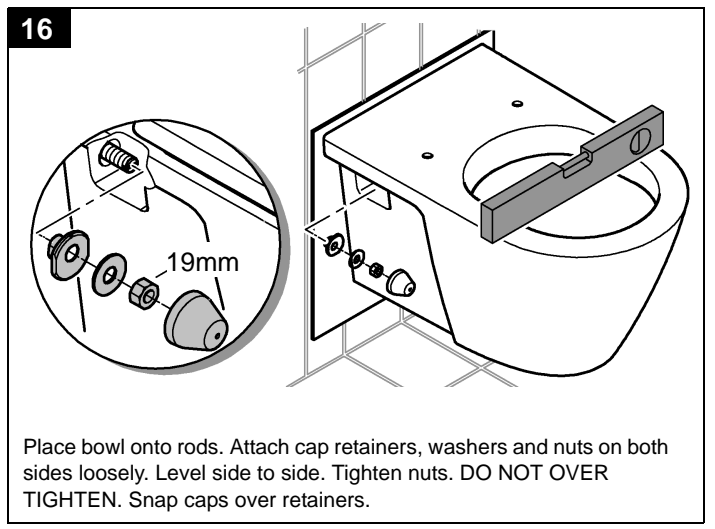
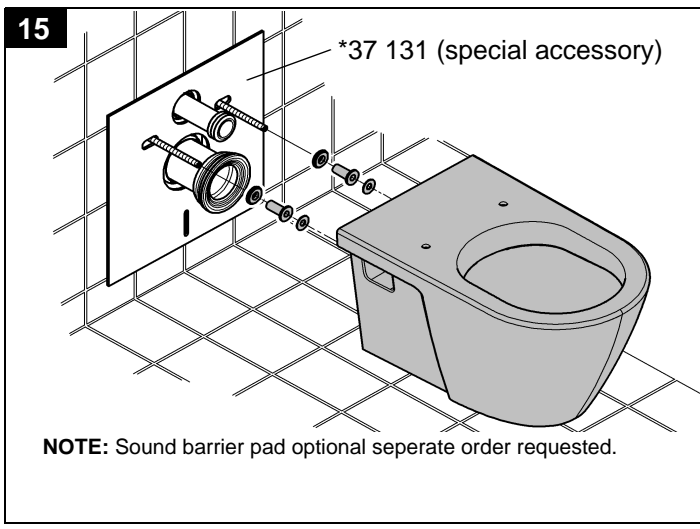
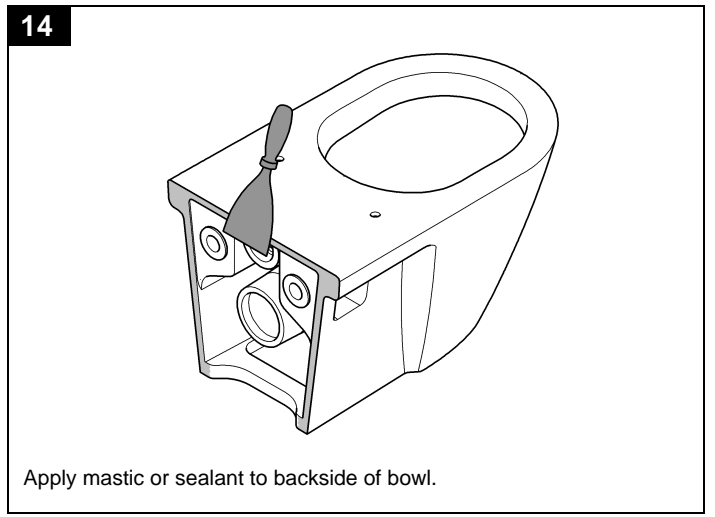
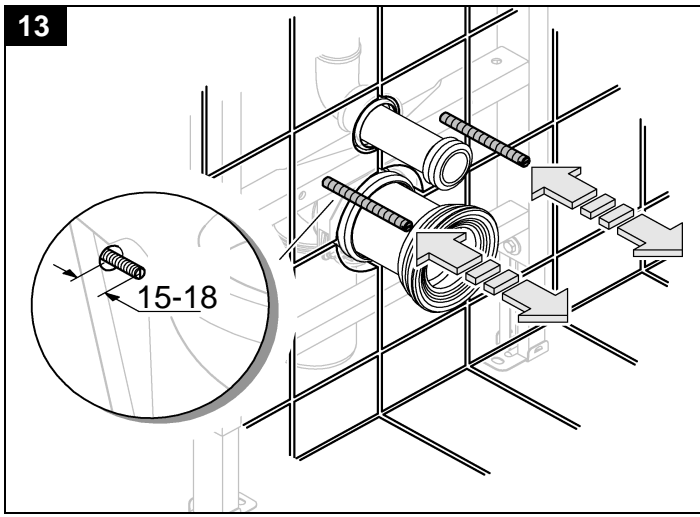
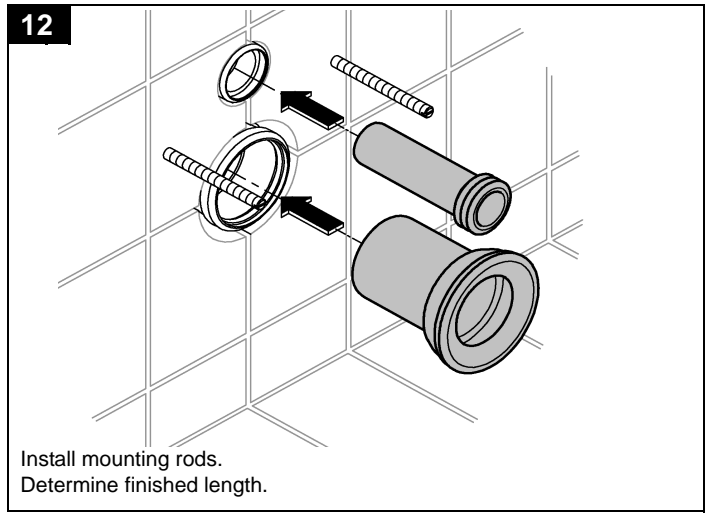
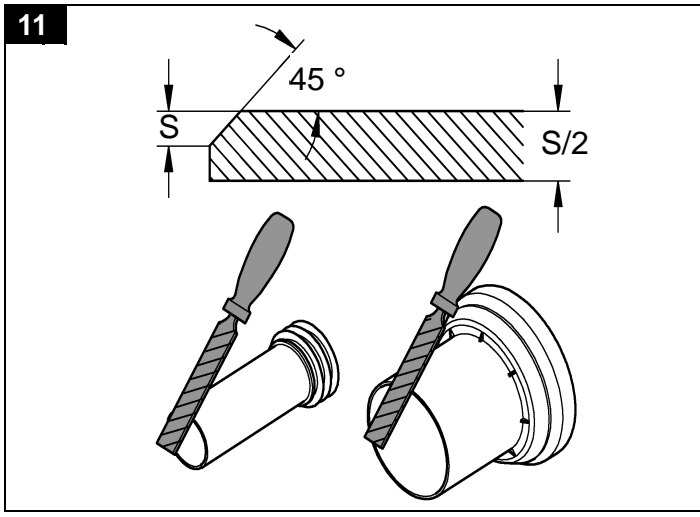

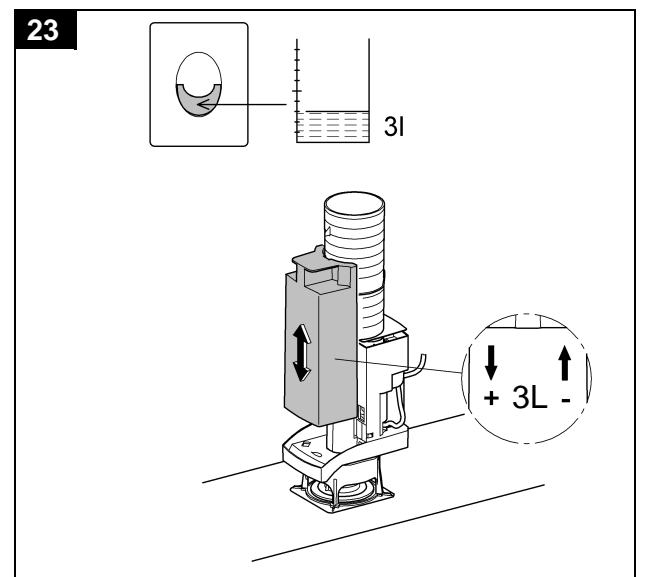
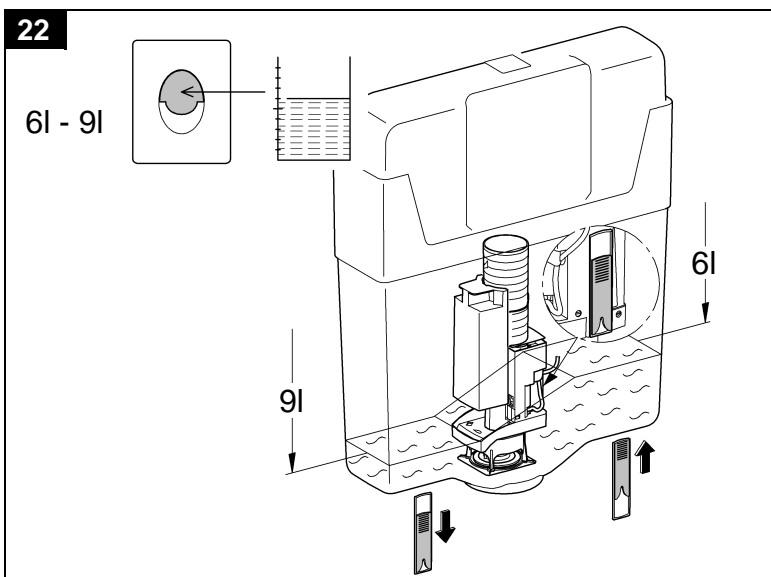
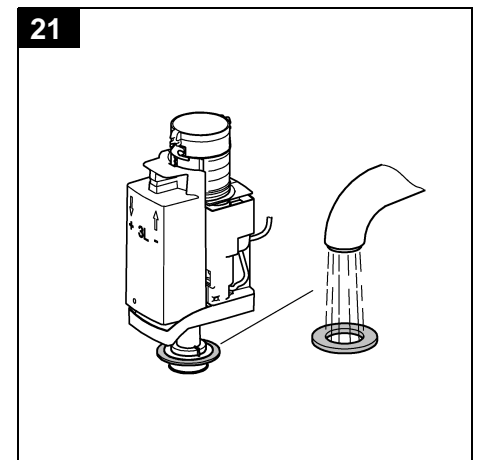
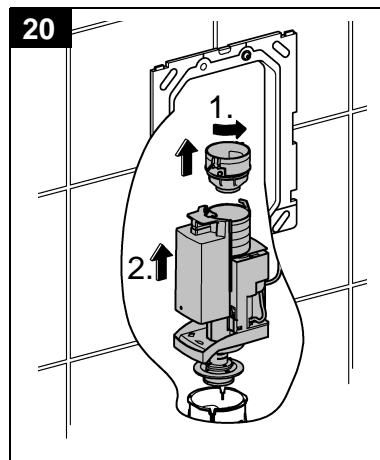
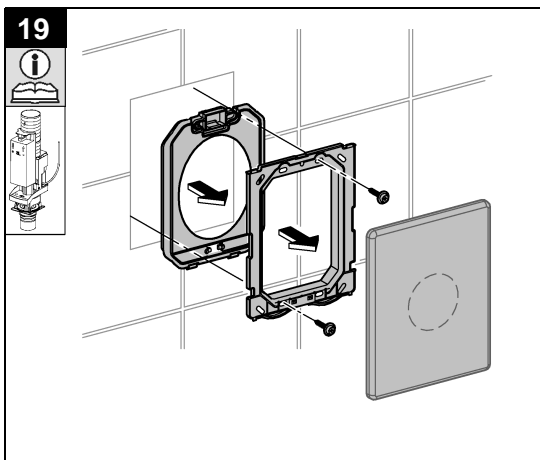
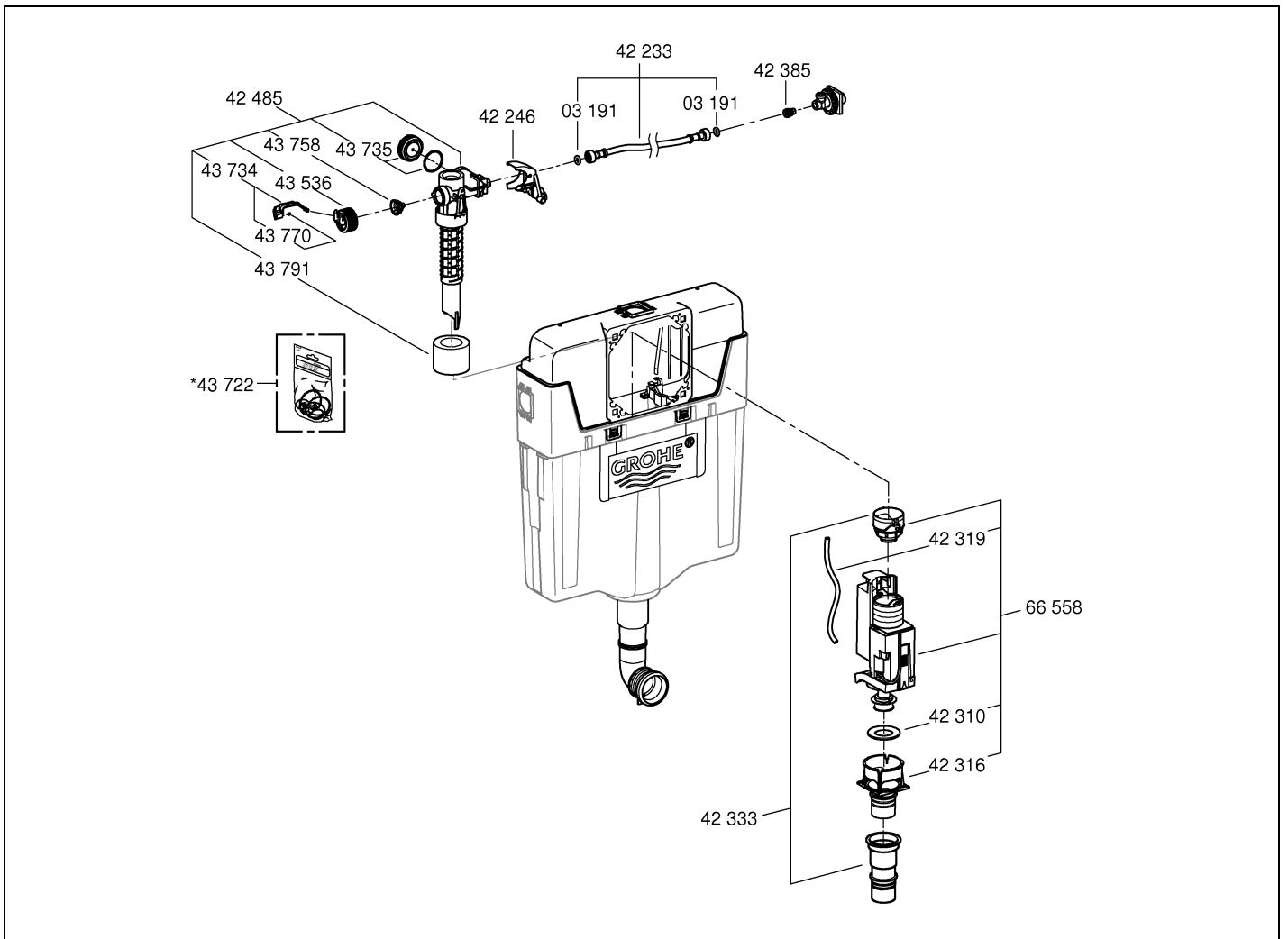

24

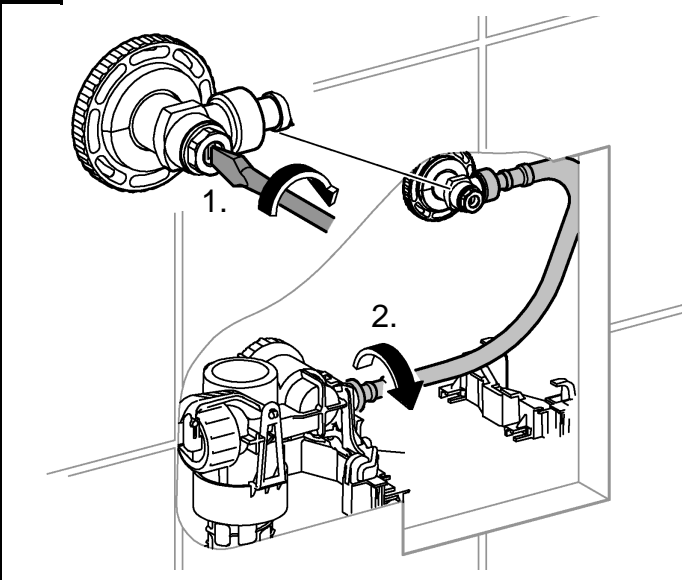

25

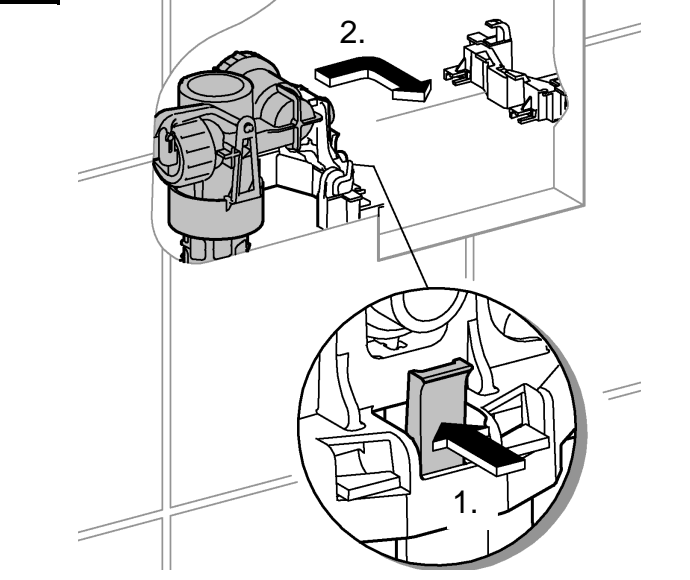

26

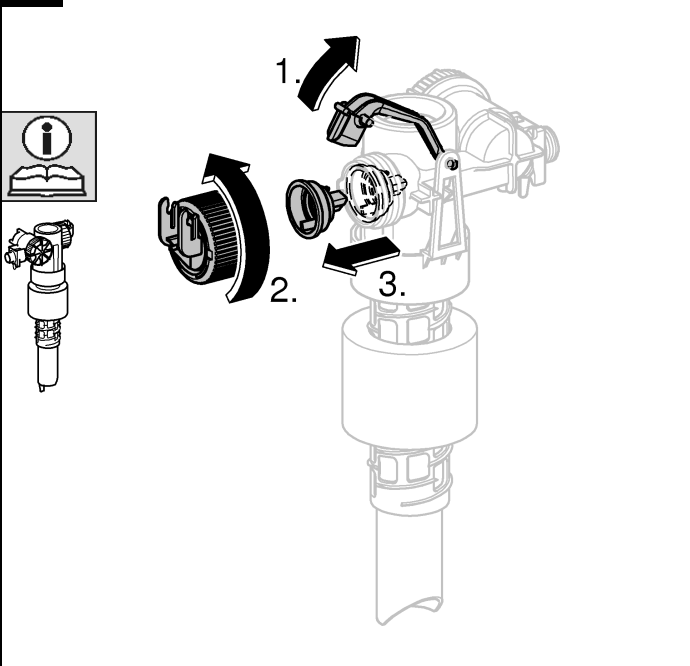

27

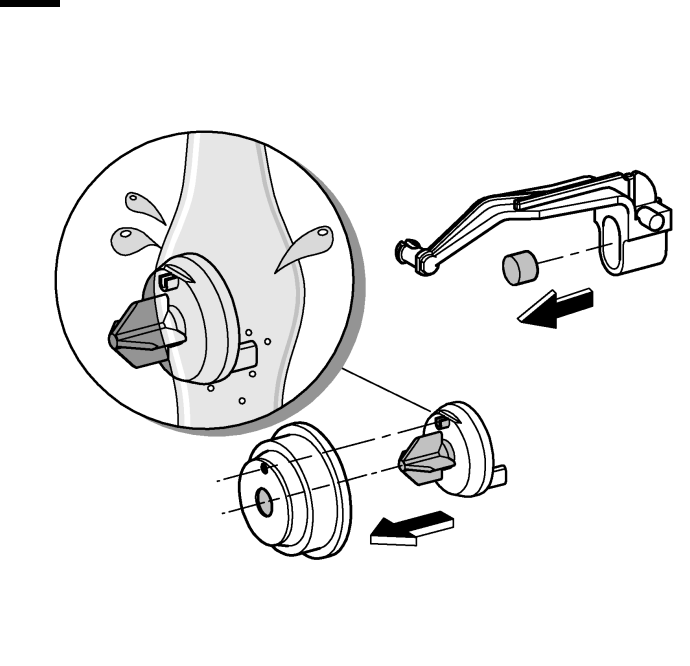

28

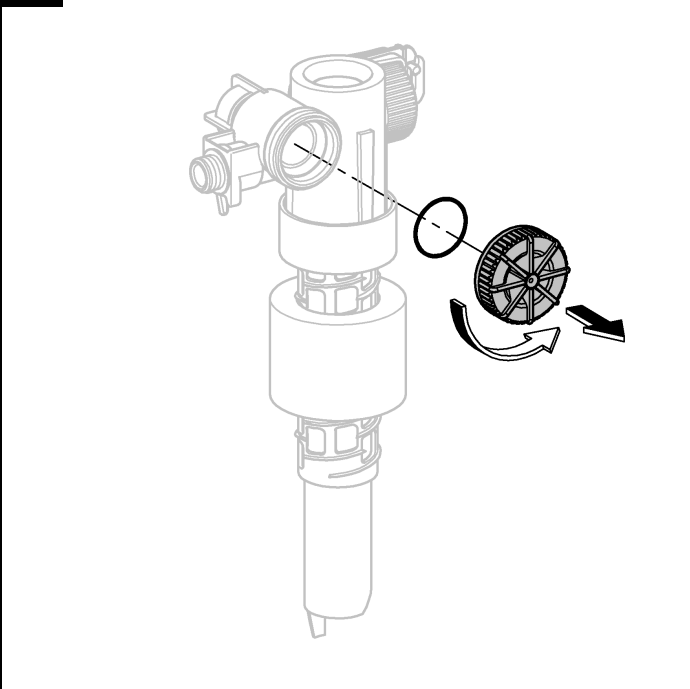

29

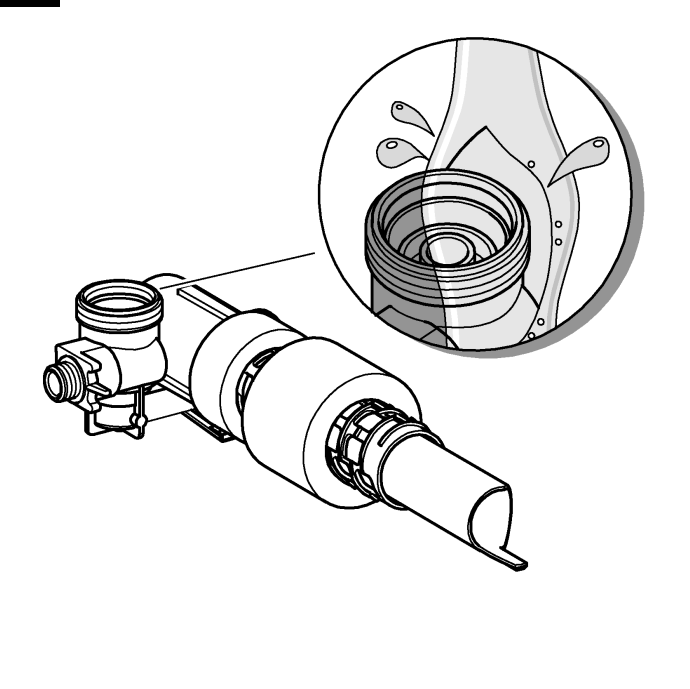

## LIMITED WARRANTY

Flushing System Products: GROHE provides the following warranties on its flushing system products to the original purchaser, installed in a residential application. Flushing system products must be installed in accordance with local plumbing codes; GROHE does not extend this warranty to (nor implies) local code compliance.

A Limited Lifetime Warranty is provided on the carrier and tank shell to be free from manufacturing defects in materials and workmanship under normal use for as long as the original purchaser owns their home.

A Ten-Year Limited Warranty is provided on the flushing mechanism (fill and discharge valves) to be free from manufacturing defects in materials and workmanship under normal use for as long as the original purchaser owns their home.

At its option, GROHE will repair or replace any part that proves to be defective in material and/or workmanship under normal installation, use and service.

To obtain warranty repair or replacement the faulty part or product is to be sent along with proof-of-purchase (original sales receipt) from the original consumer purchaser to:

+1 800 4447643  
us-customerservice@grohe.com

This warranty is extended to the original consumer owner, but does not cover installation or any other labor charges and shall not apply to any products or parts of products which have been:

- a) Repaired by unqualified persons or not using original GROHE spare parts or altered in any manner unless previously authorized in writing by GROHE; or
- b) Damaged as a result of misuse, negligence, accident or faulty installation or maintenance; or
- c) Installed or used in a manner contrary to GROHE's printed instructions; or
- d) Damaged by the effects of dirt, limescale or aggressive cleaners.

This is the exclusive warranty by GROHE, which does not make any other warranty of any kind, including the implied warranty of merchantability.

This warranty excludes all industrial, commercial, and business usage whose purchasers are extended a one (1) year limited warranty from the date of purchase, with all other terms of this warranty. (See following for commercial products.)

Commercial Products: Grohe warrants its products installed in a commercial application to be free from manufacturing defects for a period of one (1) year from the date of acquisition by original owner. Replaced products or parts are warranted only for the period remaining under the initial warranty.

THIS WARRANTY IS LIMITED SOLELY TO THE ABOVE AND THIS WARRANTY AND ANY WARRANTIES IMPLIED BY STATE LAW WILL APPLY ONLY FOR THE APPLICABLE WARRANTY PERIOD SPECIFIED HEREIN. ALSO, GROHE WILL NOT BE LIABLE FOR ANY LOSS, DAMAGE, EXPENSE OR INCIDENTAL OR CONSEQUENTIAL DAMAGES OF ANY KIND, WHETHER BASED ON WARRANTY, CONTRACT OR NEGLIGENCE AND ARISING IN CONNECTION WITH THE SALE, USE OR REPAIR OF THE PRODUCT. SOME STATES DO NOT ALLOW THE EXCLUSION OR LIMITATION OF CONSEQUENTIAL DAMAGE OR LIMITATIONS ON HOW LONG AN IMPLIED WARRANTY LASTS, SO THE ABOVE LIMITATIONS OR EXCLUSIONS MAY NOT APPLY. THIS WARRANTY GIVES YOU SPECIFIC LEGAL RIGHTS, AND YOU MAY ALSO HAVE OTHER RIGHTS WHICH VARY FROM STATE TO STATE. UNLESS OTHERWISE CONTRARY TO STATE LAW GOVERNING THE PURCHASE, GROHE'S LIABILITY WILL NOT EXCEED THE CONTRACT PRICE FOR THE PRODUCT CLAIMED TO BE DEFECTIVE OR UNSUITABLE.

Pure Freude an Wasser

**GROHE**  
WAVES

- D**  
& +49 571 3989 333  
helpline@grohe.de
- A**  
& +43 1 68060  
info-at@grohe.com
- AUS**  
& +(61) 1300 54945  
grohe\_australia@lixil.com
- B**  
& +32 16 230660  
info.be@grohe.com
- BG**  
& +359 2 9719959  
grohe-bulgaria@grohe.com
- BR**  
& 0800 770 1222  
falecom@grohe.com
- CAU**  
& +99 412 497 09 74  
info-az@grohe.com
- CDN**  
& +1 888 6447643  
info@grohe.ca
- CH**  
& +41 44 877 73 00  
info@grohe.ch
- CN**  
& +86 4008811698  
info.cn@grohe.com
- CY**  
& +357 22 465200  
info@grome.com
- CZ**  
& +358 942 451 390  
grohe-cz@grohe.com
- DK**  
& +45 44 656800  
grohe@grohe.fi
- E**  
& +34 93 3368850  
grohe@grohe.es
- EST**  
& +372 6616354  
grohe@grohe.ee
- F**  
& +33 1 49972900  
sav-fr@grohe.com
- FIN**  
& +358 942 451 390  
grohe@grohe.fi
- GB**  
& +44 871 200 3414  
info-uk@grohe.com
- GR**  
& +30 210 2712908  
nsapountzis@ath.forthnet.gr
- H**  
& +36 1 2388045  
info-hu@grohe.com
- HK**  
& +852 2969 7067  
info@grohe.hk
- I**  
& +39 2 959401  
info-it@grohe.com
- IND**  
& +91 1800 102 4475  
customercare.in@grohe.com
- IS**  
& +354 515 4000  
jonst@byko.is
- J**  
& +81 3 32989730  
info@grohe.co.jp
- KZ**  
& +7 727 311 07 39  
info-cac@grohe.com
- LT**  
& +372 6616354  
grohe@grohe.ee
- LV**  
& +372 6616354  
grohe@grohe.ee
- MAL**  
info-malaysia@grohe.com
- MX**  
& 01800 8391200  
pregunta@grohe.com
- N**  
& +47 22 072070  
grohe@grohe.no
- NL**  
& +31 79 3680133  
vragen-nl@grohe.com
- NZ**  
technicalenquiries@  
patersontrading.co.nz
- P**  
& +351 234 529620  
commercial-pt@grohe.com
- PL**  
& +48 22 5432640  
biuro@grohe.com.pl
- RI**  
& 0-800-1-046743  
customercare-  
indonesia@asia.lixil.com
- RO**  
& +40 21 2125050  
info-ro@grohe.com
- ROK**  
& +82 2 1588 5903  
info-singapore@grohe.com
- RP**  
& +63 2 8938681
- RUS**  
& +7 495 9819510  
info@grohe.ru
- S**  
& +46 771 141314  
grohe@grohe.se
- SGP**  
& +65 6311 3611  
info-singapore@grohe.com
- SK**  
& +420 277 004 190  
grohe-cz@grohe.com
- T**  
& +66 21681368  
(Haco Group)  
info@haco.co.th
- TR**  
& +90 216 441 23 70  
GroheTurkey@grome.com
- UA**  
& +38 44 5375273  
info-ua@grohe.com
- USA**  
& +1 800 4447643  
us-customerservice@grohe.com
- VN**  
& +84 90 9694768  
& +84 90 9375068  
info-vietnam@grohe.com
- AL** **BiH** **HR** **KS**  
**ME** **MK** **SLO** **SRB**  
& +385 1 2911470  
adria-hr@grohe.com
- Eastern Mediterranean,  
Middle East - Africa  
Area Sales Office:**  
& +357 22 465200  
info@grome.com
- IR** **OM** **UAE** **YEM**  
& +971 4 3318070  
grohedubai@grome.com
- Far East Area Sales Office:**  
& +65 6311 3600  
info@grohe.com.sg
- Latin America:**  
& +52 818 3050626  
pregunta@grohe.com