

# SPECIFICATION SHEET

PRODUCT FAMILY: Sinks FINISH: Stainless Steel SERIES: CENTENNIAL MODEL: CQX11024

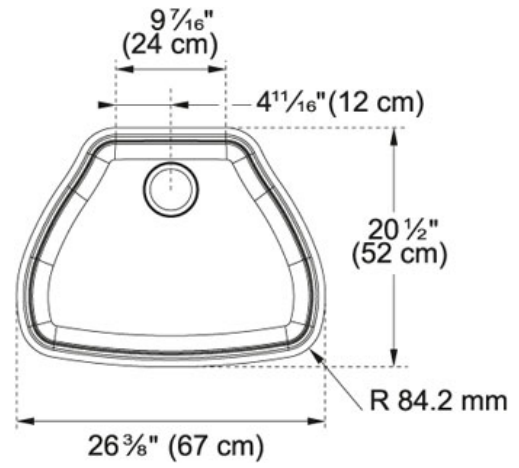

## Product Information

<b>FUN#</b>	122.0183.744
<b>US Part Number</b>	CQX11024
<b>Minimum Cabinet Size</b>	30"
<b>Outer Dimensions</b>	26 3/8"x20 7/16"
<b>Bowl Size</b>	24 1/8"x18 1/8"x9"
<b>Number of Bowls</b>	1

**Accessories**

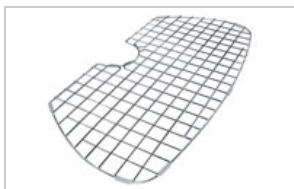

112.0195.447

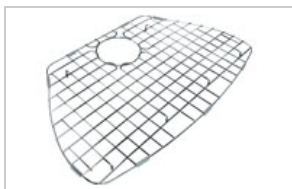

112.0195.448



112.0195.454

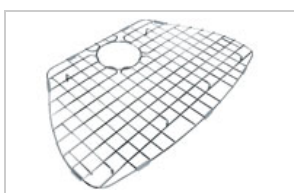

112.0196.893

**Suggested Products**



115.0067.287



119.0191.643