

# 110-V30 30" Vanity

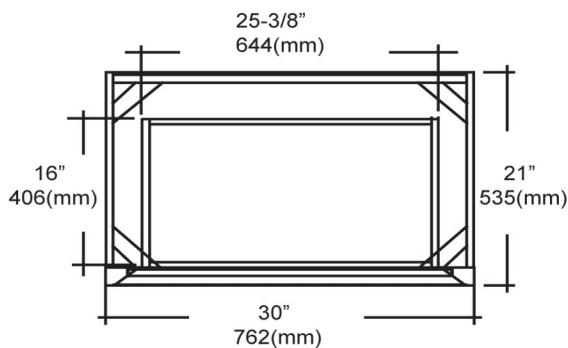
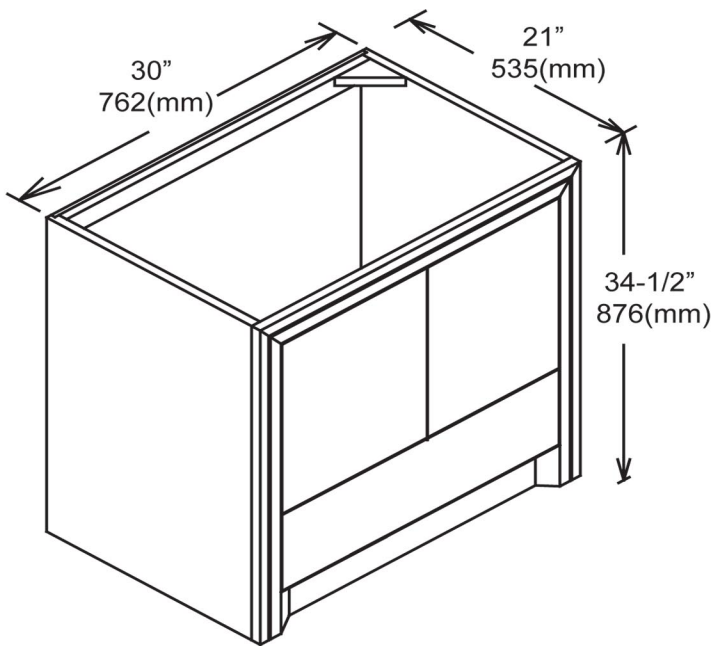

## SPECIFICATION SHEET

### Features

Materials: Red Oak solids with Red Oak veneers

Hinges: Fully concealed, soft closing

Doors: 2

Glides: Soft closing

Drawers: 1

Drawer Boxes: 1/2" solid pine, four sided English dovetail

Shelves: 1

Back panel: Fully covered

Side Panels: 5/8" PB with Red Oak veneers

### Colors / Finish

110-Espresso

